

This board is supported by 2 28 pins DIL plugs,  
 one in the master (ZIF-1) and one in ZIF-4 for the stability.  
 On the 4 corners the correct distance is also maintained by 4 small bolts. (standoff's)

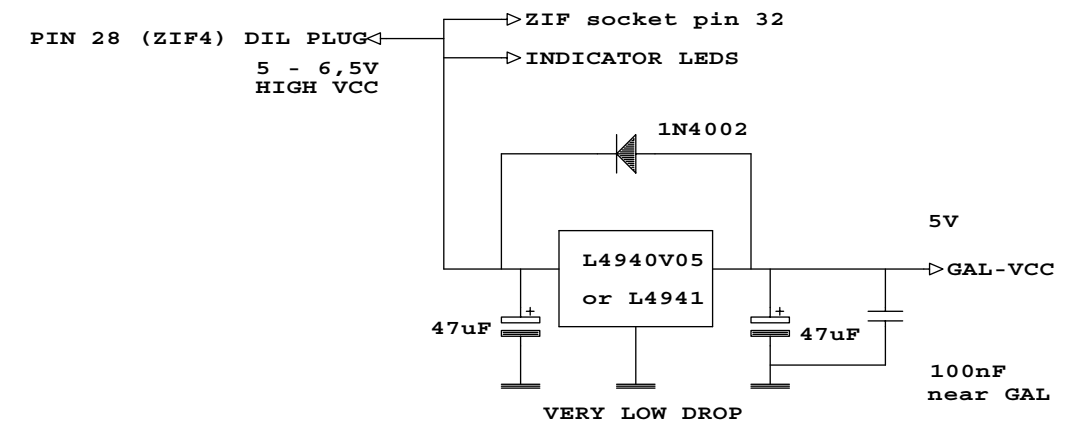
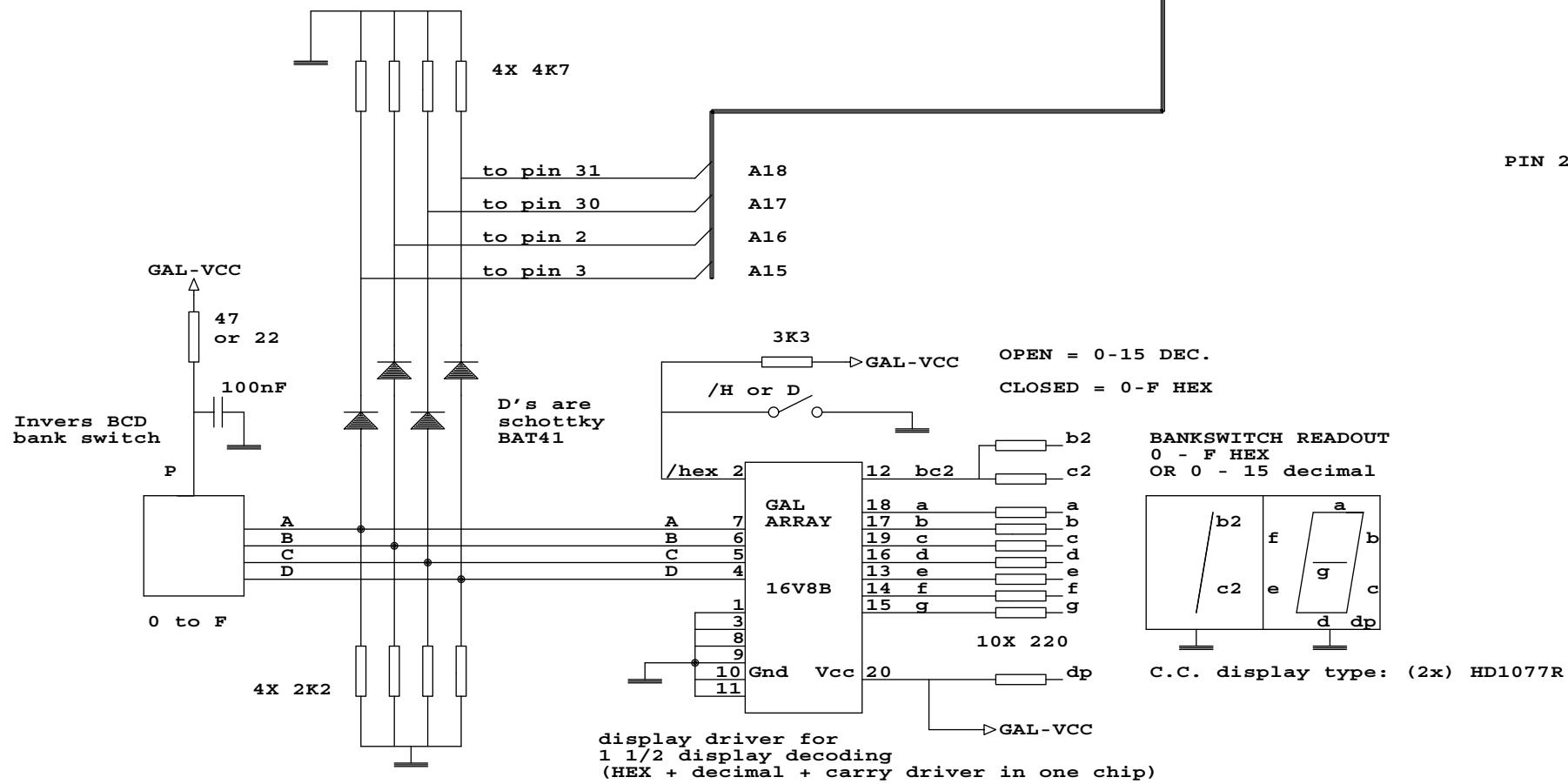
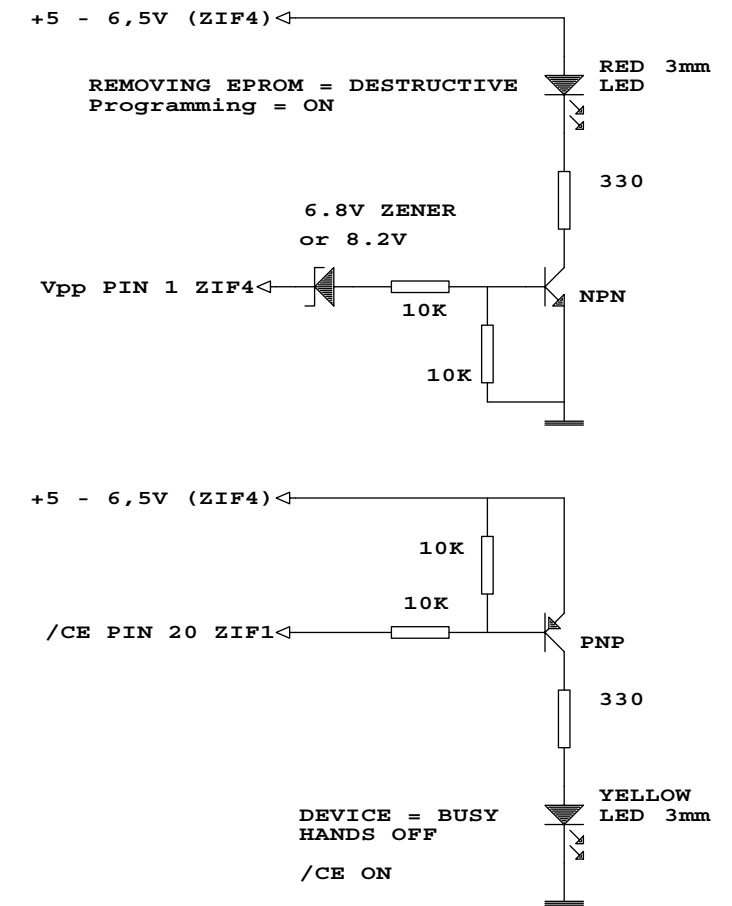

**PROGRAMS ONLY 27C4000 EPROMS**  
 in 27C256 programming mode (BANKS)  
 For 271000-2000, use other adapter  
 REV2.2: corrected A14 on pin 27 DIL plug

Title		
BANKSWITCH UNIT FOR SUNSHINE EW 904 SERIES		
Size	Document Number	REV
B	CREATED BY W. GEERAERT	2.2
Date:	December 9, 2007	Sheet of