



# INTEGRATED CIRCUIT

## TECHNICAL DATA

# TA7310P

TOSHIBA BIPOLAR LINEAR INTEGRATED CIRCUIT

SILICON MONOLITHIC

FOR PHASE LOCKED LOOP FREQUENCY SYNTHESIZER.

- . Doubly Balanced Mixer
- . Emitter Follower Circuit
- . Differential Amplifier
- . Wide Operating Supply Voltage Range :  $V_{CC}=6 \sim 10V$

Polished by PE1ABR

### MAXIMUM RATINGS (Ta=25°C)

CHARACTERISTIC	SYMBOL	RATING	UNIT
Supply Voltage	V <sub>CC</sub>	10	V
6 Pin Supply Voltage	V <sub>6</sub>	14	V
1 Pin Supply Voltage	V <sub>9</sub>	20	V
Power Dissipation (Note)	P <sub>D</sub>	600	mW
Operating Temperature	T <sub>opr</sub>	-30 ~ 75	°C
Storage Temperature	T <sub>stg</sub>	-55 ~ 150	°C

Note : Derated above Ta=25°C in the proportion of 4.8mW/°C.

Unit in mm

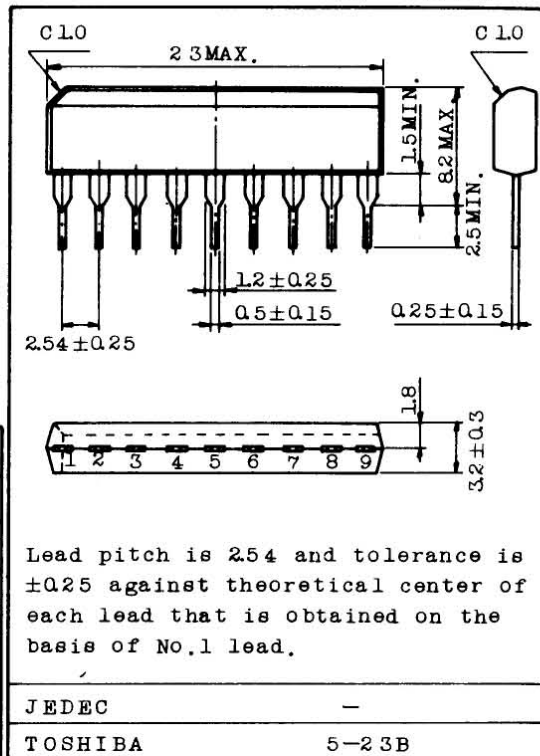

### EQUIVALENT CIRCUIT

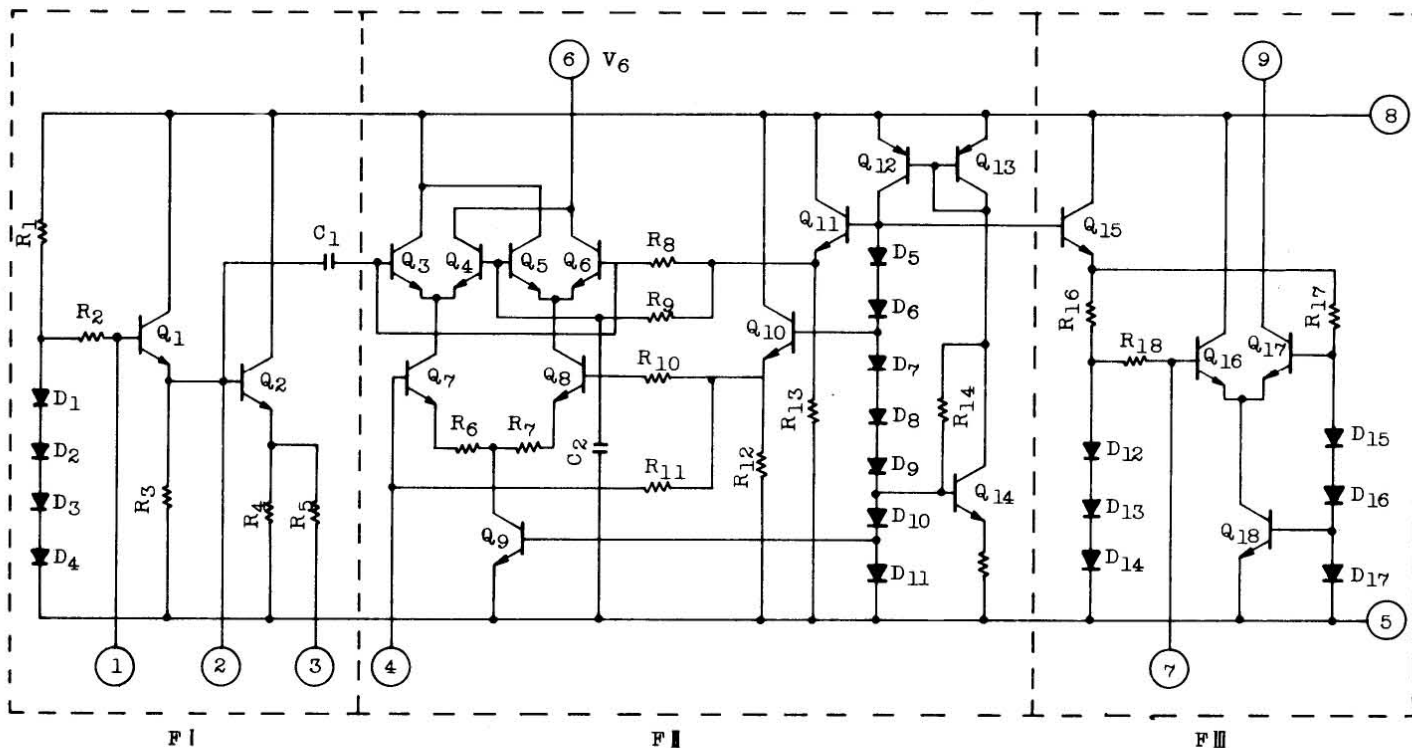

#### ELECTRICAL CHARACTERISTICS (Ta=25°)

CHARACTERISTIC		SYMBOL	TEST CIR-CUIT	TEST CONDITION	MIN.	TYP.	MAX.	UNIT
Supply Current		I <sub>CC</sub>	1	V <sub>CC</sub> =7V	21.5	-	38.0	mA
6 Pin Supply Current		I <sub>6</sub>	1	V <sub>CC</sub> =7V	3.0	-	5.5	mA
9 Pin Maximum Supply Current		I <sub>9</sub> (Max)	1	V <sub>CC</sub> =7V, 7pin GND	6.0	-	12.0	mA
Output Power		P <sub>o</sub>	2	V <sub>CC</sub> =7V, V <sub>9</sub> =12V f=26.965MHz	6.0	10	-	mW
Differential Amplifier Input Impedance	7 Pin Parallel Input Resistance	R <sub>ip7</sub>	10	V <sub>CC</sub> =7V, f=27MHz	-	1.0	-	kΩ
	7 Pin Parallel Input Capacitance	C <sub>ip7</sub>			-	6.5	-	pF
Differential Amplifier Output Impedance	9 Pin Parallel Output Resistance	R <sub>op9</sub>	11	V <sub>CC</sub> =7V, V <sub>9</sub> =12V, f=27MHz	-	4.0	-	kΩ
	9 Pin Parallel Output Capacitance	C <sub>op9</sub>			-	4.0	-	pF
Doubly Balanced Mixer Input Impedance	4 Pin Parallel Input Resistance	R <sub>ip4</sub>	12	V <sub>CC</sub> =7V, f=10MHz	-	1.5	-	kΩ
	4 Pin Parallel Input Capacitance	C <sub>ip4</sub>			-	4.3	-	pF
Doubly Balanced Mixer Output Impedance	6 Pin Parallel Output Resistance	R <sub>op6</sub>	13	V <sub>CC</sub> =7V, f=27MHz	-	3.5	-	kΩ
	6 Pin Parallel Output Capacitance	C <sub>op6</sub>			-	6.0	-	pF



# INTEGRATED CIRCUIT

## TA7310P

### TECHNICAL DATA

#### TEST CIRCUIT

1.  $I_{CC}$ ,  $I_6$ ,  $I_9$  (Max.)

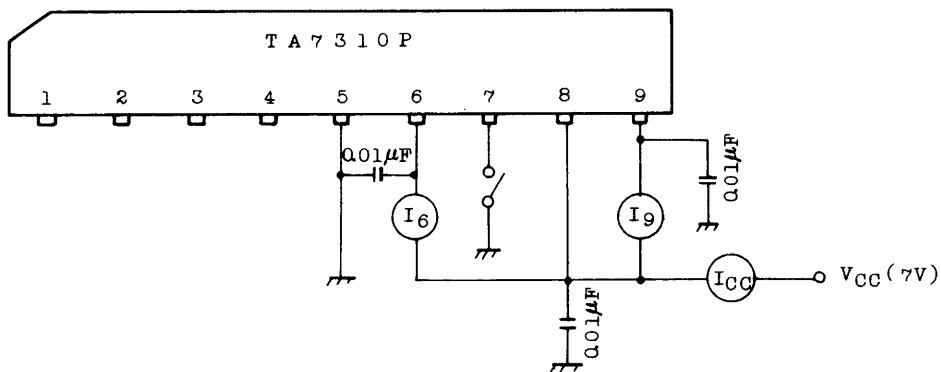

2.  $P_o$

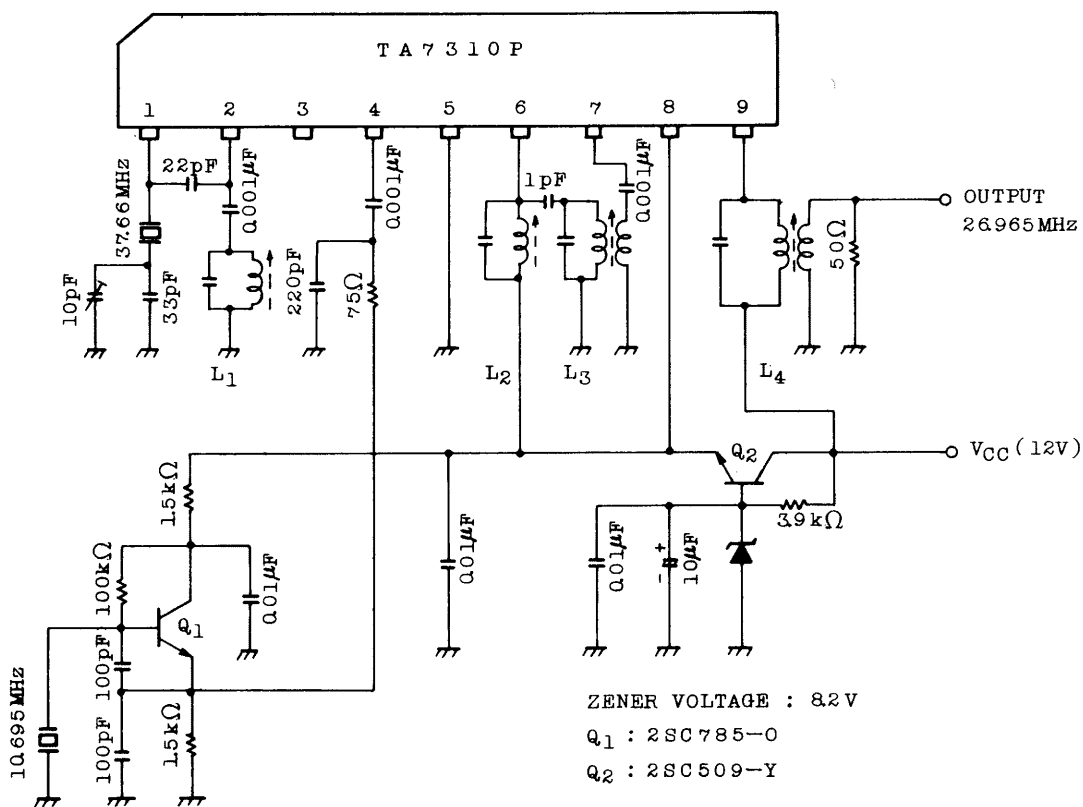

COIL DATA (10mm □) TABLE 1

		L1	L2	L3	L4
Primary	TURNS	3T	6T	6T	12T
	L	0.6µH	0.3µH	0.3µH	1.2µH
	C	56pF	100pF	100pF	30pF
Secondary	TURNS	-	-	2T	2T



# INTEGRATED CIRCUIT

## TECHNICAL DATA

### TA7310P

#### 3. $V_O - V_{CC}$ (8 PIN)

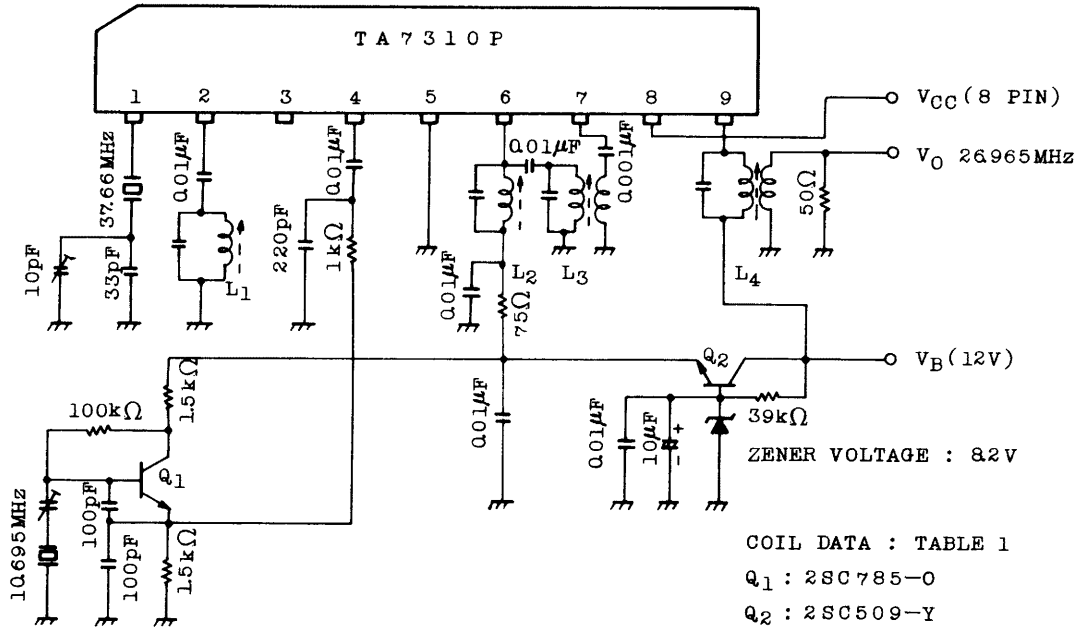

#### 4. $V_O - V_{IN}$

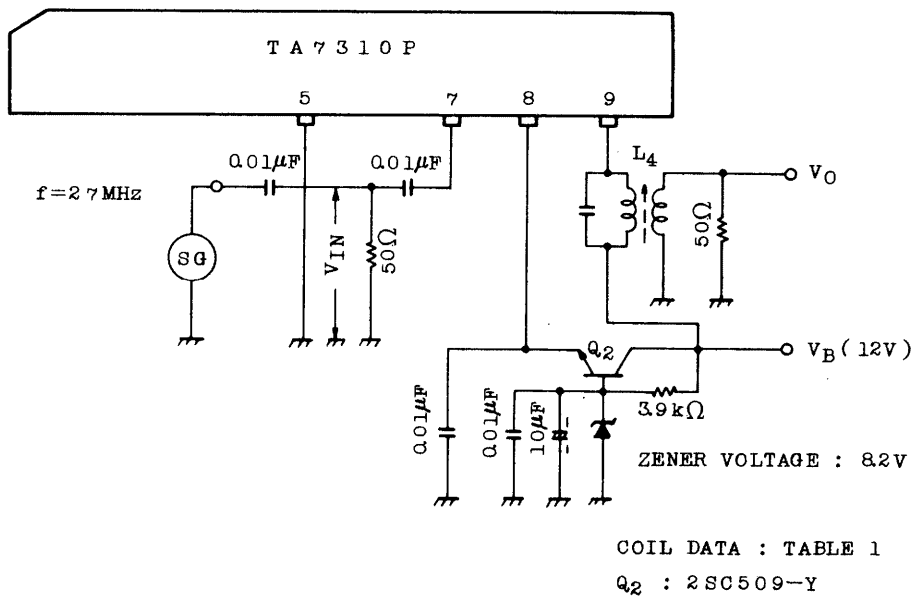



# INTEGRATED CIRCUIT

# TA7310P

## TECHNICAL DATA

### 5. $V_O(9) - f$

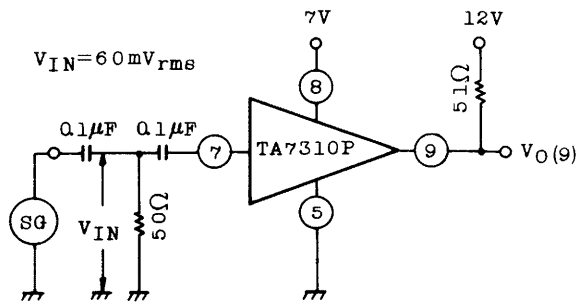

### 6. $V_O(6) - f$

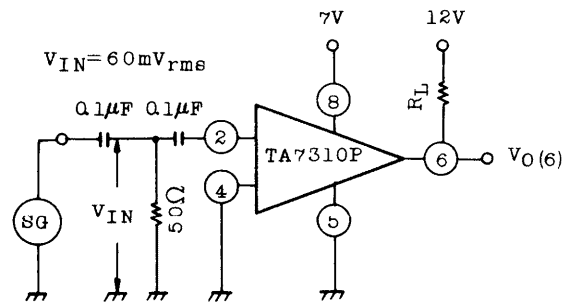

### 7. CARRIER FEED THROUGH ( $V_O(6) - f$ )

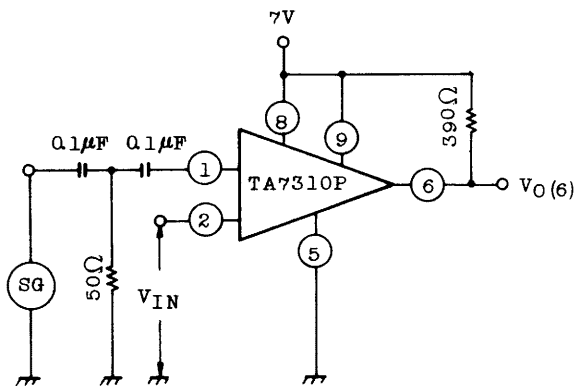

### 8. SIDE BAND HARMONIC SUPPRESSION - LOCAL OSC. LEVEL

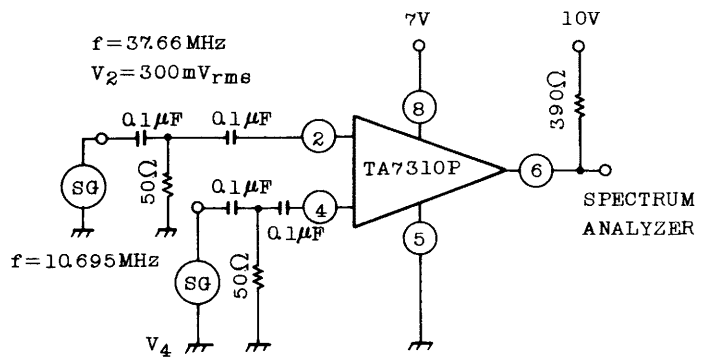

### 9. $V_O - V_4$

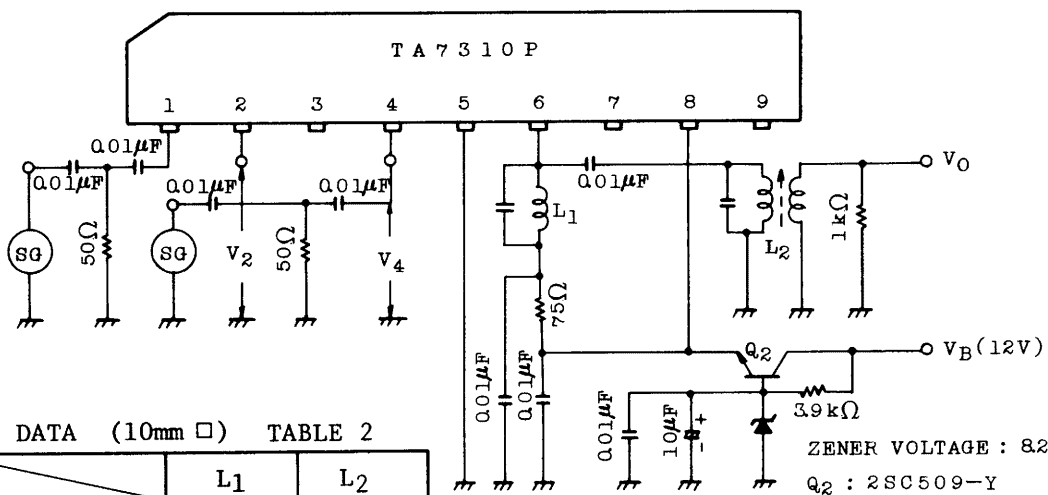

COIL DATA (10mm □) TABLE 2

		L1	L2
Primary	TURNS	6T	6T
	L	0.3µH	0.3µH
	C	100pF	100pF
Secondary	TURNS	-	2T



# INTEGRATED CIRCUIT

## TECHNICAL DATA

# TA7310P

10. Rip7, Cip7

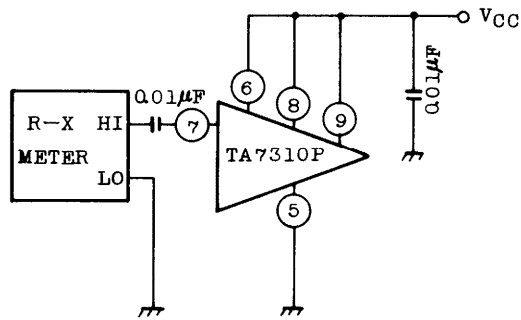

11. Rop9, Cop9

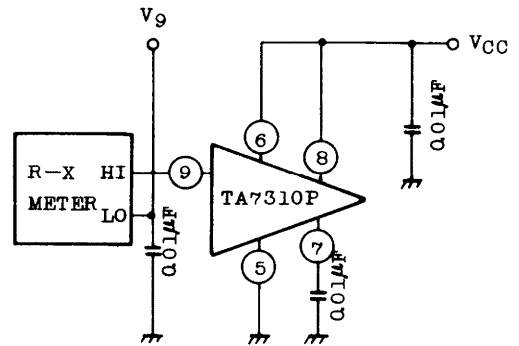

12. Rip4, Cip4

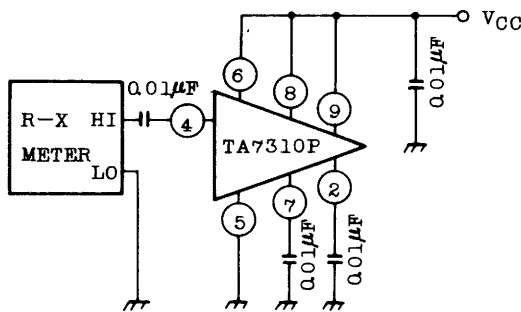

13. Rop6, Cop6

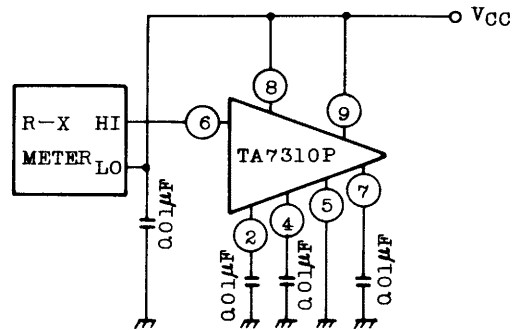

14. V<sub>O(6)</sub> - f

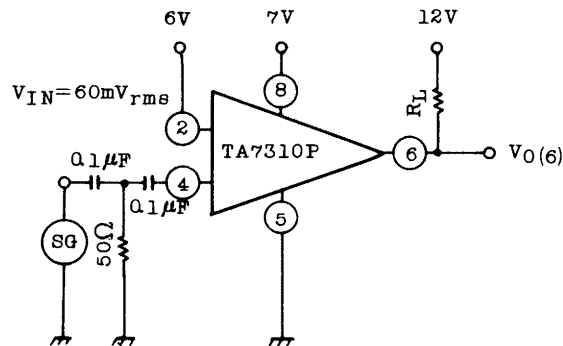



# INTEGRATEDCIRCUIT

## TECHNICAL DATA

# TA7310P

$P_o - T_a$

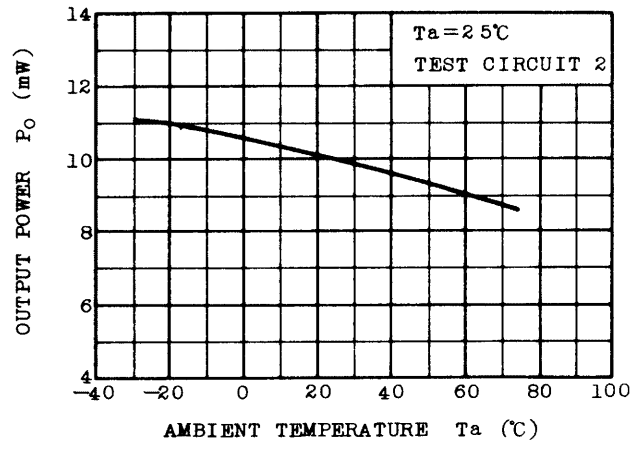

$V_o - V_{CC}$

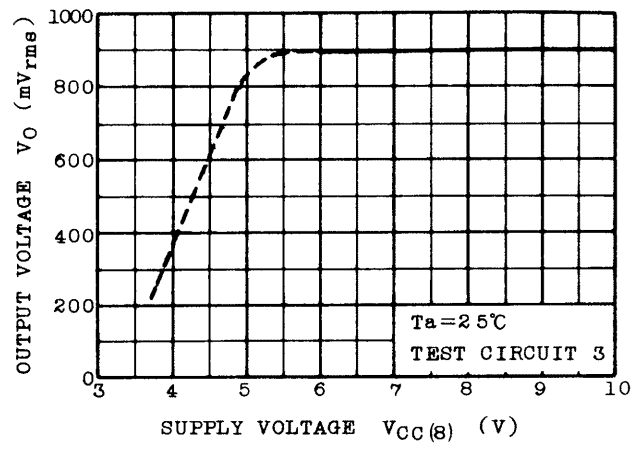

$V_o - V_{IN}$

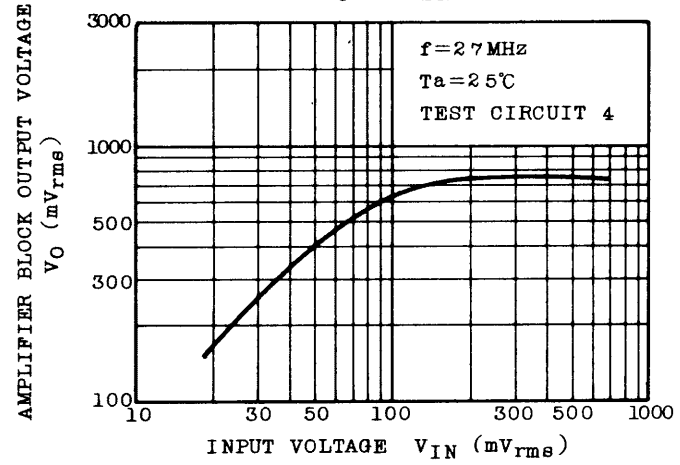

$V_{O(9)} - f$

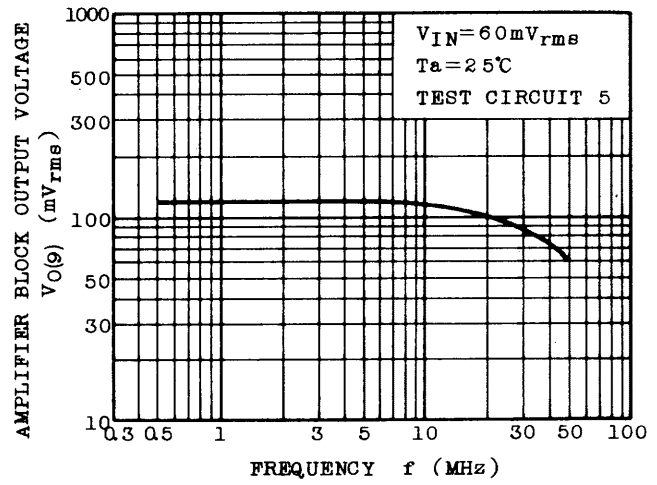

$V_{O(6)} - f$

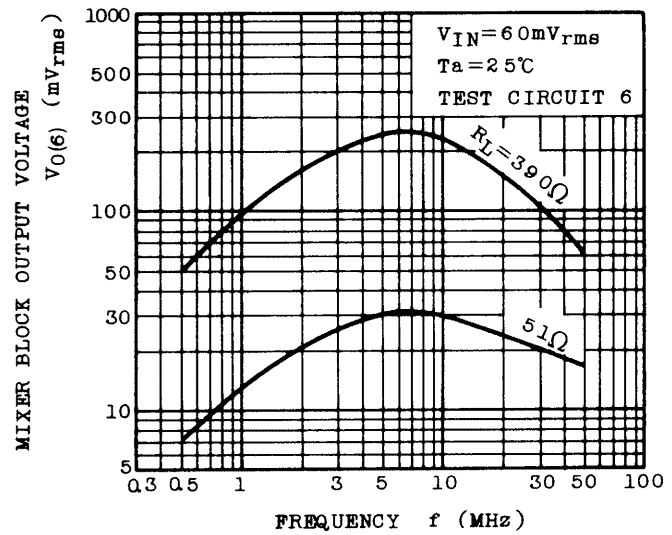

$V_{O(6)} - f$

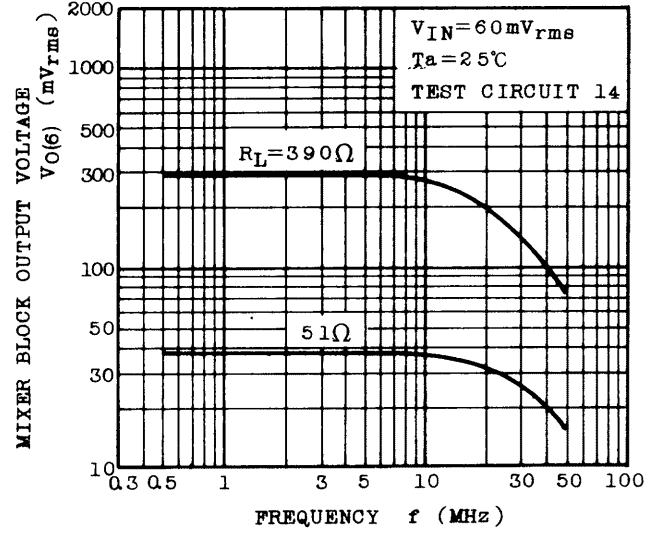

### TECHNICAL DATA

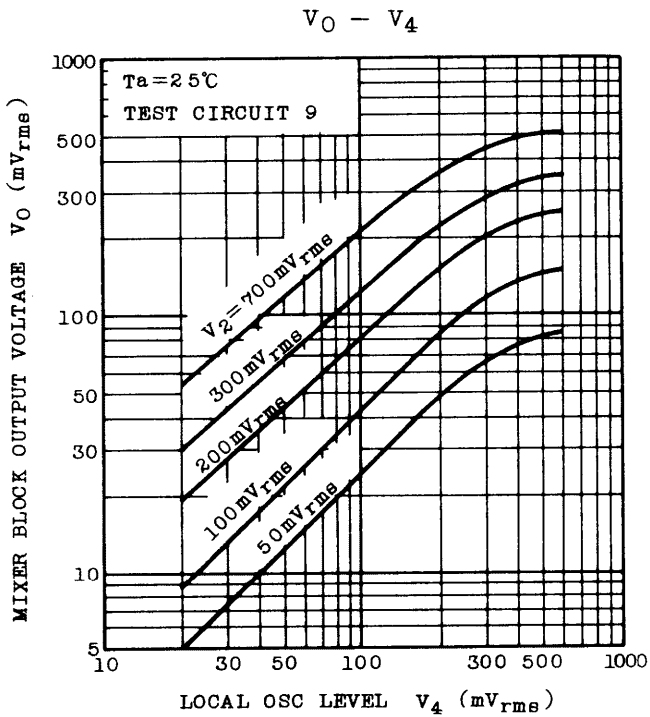
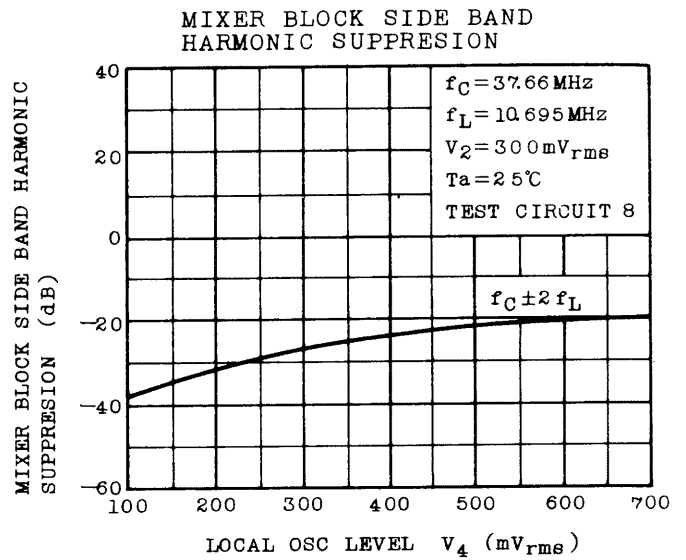
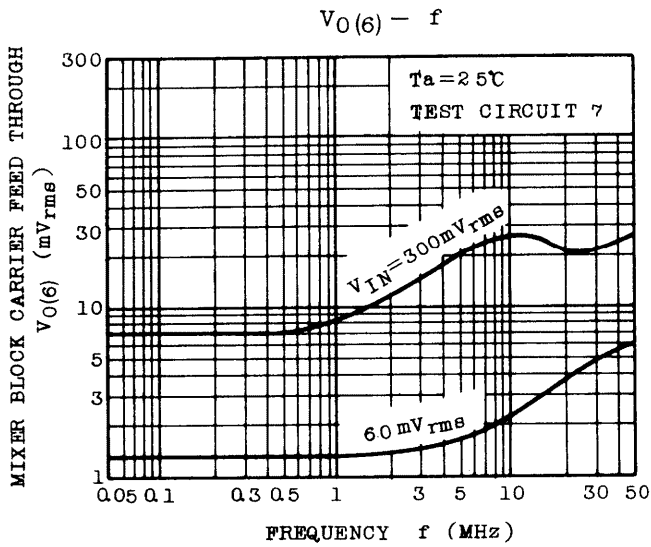



APPLICATION BLOCK DIAGRAM

TA7310P is designed especially for use in CB transceiver in conjunction with TA9106BP frequency synthesizer.

The functions incorporated are emitter follower circuit (F I), doubly balanced mixer (F II) and differential amplifier (F III).

Emitter follower circuit may be used as reference oscillator or VCO.

Differential amplifier may be used wide band RF amplifier.

