



UM91270

20 Memory Tone/Pulse Dialer

Features:

- 32-digit redial memory (31 digits in tone mode).
- Twenty 18-digit number memories (17 digits in tone mode) with direct access keys.
- Tone/pulse mode switching: tone capability available in pulse mode through use of the "T" (pulse to tone) key.
- Low operating voltage: 1.8 to 5.0 V in pulse mode
2.5 to 5.0 V in tone mode.
- Can be used with 480 KHz ceramic resonator.
- Selectable make/break ratio.
- Selectable dialing rate.

- Flash can be stored in digit form; 0.6 second flash, 1.6 second pause.
- Page mode: M1 to M10 first page, M11 to M20 second page.
- 100 ms minimum tone output duration.
100 ms minimum interdigit pause.
- 4.0 second access pause.
- Memory transfer from number to redial memory in dialing mode.
- Allows overflow in normal dialing.

Tone/Pulse Dialer

General Description

The UM91270 is a switchable tone/pulse dialer with twenty 18-digit number memories and a 32-digit redial memory. Pulse to tone mode switching can be performed either by using a slide switch or by depressing the tone key, UMC's HCMOS-2B technology has been used to produce this device, resulting in low power requirements, high noise immunity, and easy interfacing with a variety of telephones.

Ordering Information

Part No.	Access Pause	Flash	Package
UM91270	4 s	600 ms	P-DIP 28L
UM91270A	4 s	100 ms	
UM91270B	2 s	600 ms	
UM91270M	4 s	600 ms	SO 28L
UM91270AM	4 s	100 ms	
UM91270BM	2 s	600 ms	

Pin Configuration

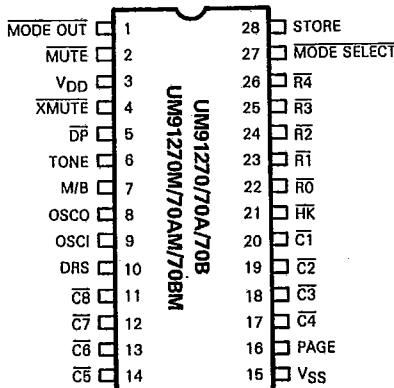

Keyboard Assignment

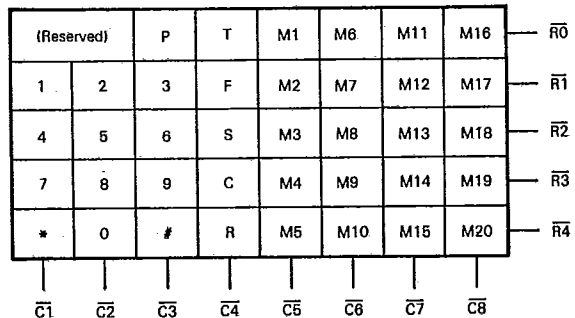

- P: Pause
- T: Pulse to Tone Key
- F: Flash
- S: Store
- C: Clear
- R: Redial

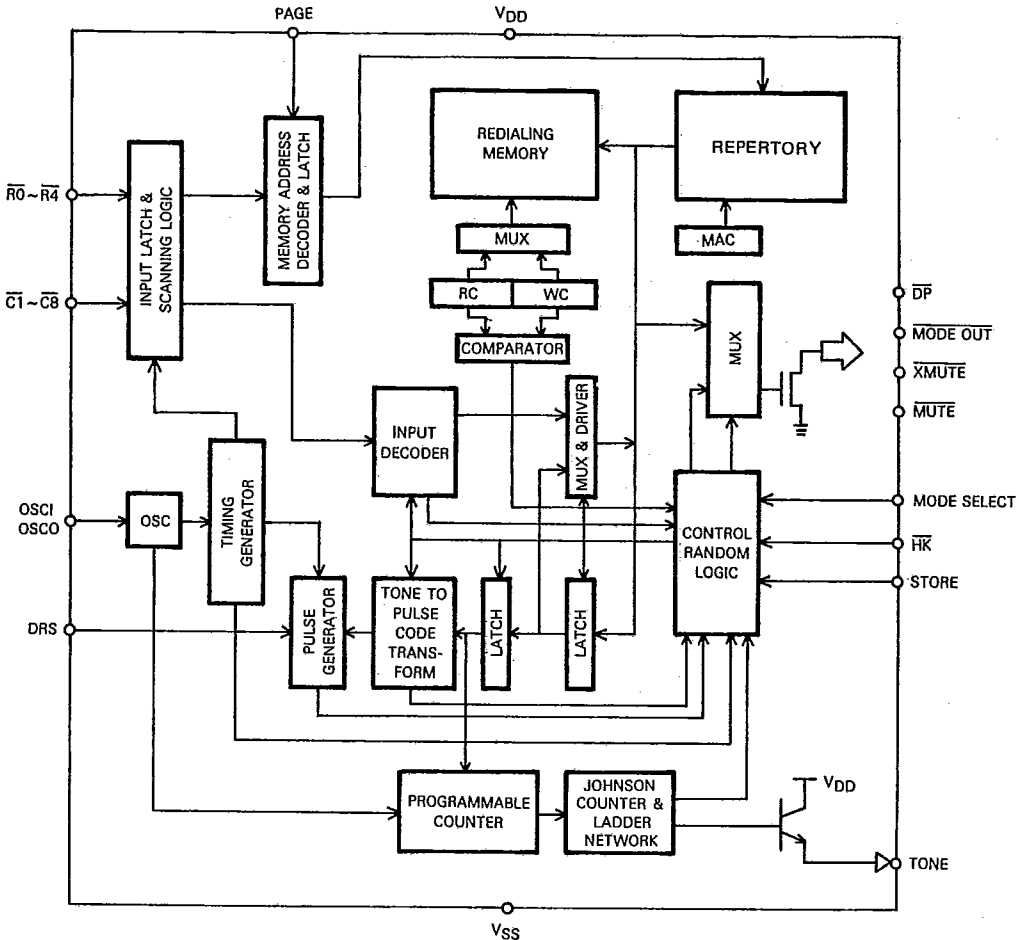
Block Diagram

Absolute Maximum Ratings *

Power supply voltage ($V_{DD}-V_{SS}$).....	-0.3V to +6.0V
Input voltage (V_{IN}).....	-0.3 to V_{DD} + 0.3V
Maximum power dissipation (at 25°C).....	600 mW
Operating temperature (T_{OP}).....	-20°C to +70°C
Storage temperature (T_{STG}).....	-55°C to +150°C

***Comments**

Stresses above those listed under "Absolute Maximum Ratings" may cause permanent damage to the device. These are stress ratings only and functional operation of the device at these or any other conditions beyond those indicated in the sections of this specification listing dealing with operational procedures is not implied.

DC Characteristics

 (V_{DD} = 3.5 V, V_{SS} = 0. V, F_{OSC} = 480 KHz, T_{OP} = 25°C, unless otherwise specified.)

Parameter	Symbol	Conditions	Min.	Typ.	Max.	Unit	Test CKT.
Operating Voltage	V _{DD}	Pulse mode	1.8		5.0	V	A
		DTMF mode	2.5		5.0		
Memory Retention Voltage	V _{MR}		1.0			V	
Memory Retention Current	I _{MR}	V _{DD} = \overline{HK} = 1 V all outputs unloaded		0.05	0.1	μA	
Standby Current	I _{SD}	\overline{HK} = V _{SS} all outputs unloaded		5	50	μA	A
Supply Operating current	I _{DDP}	oscillator running		0.16	0.5	mA	A
	I _{DDT}	all outputs unloaded		0.4	1.0	mA	
Output Sink Current DP MUTE XMUTE	I _{OL1}	V _{OL} = 0.4 V	1.0	10		mA	B
	I _{OL2}	V _{OL} = 0.4V, V _{DD} = 2.0 V	0.4	5		mA	B
Output Sink Current MODE OUT	I _{OL1}	V _{OL} = 0.4 V	3.0	10		mA	B
	I _{OL2}	V _{OL} = 0.4, V _{DD} = 2.0 V	1.0	6		mA	B
Input voltage Range	V _{IH}		0.8V _{DD}		V _{DD}	V _{DD}	
	V _{IL}		0.		0.2V _{DD}	V _{DD}	
Row Input Current	I _R	V _{IN} = 3.5V, all outputs unloaded	1	4	60	μA	C
Column Input Current	I _C	V _{IN} = 0V, all outputs unloaded	70	250	800	μA	C
Single Row Tone Output Amplitude	V _{OR}	R _{load} = 10KΩ, V _{DD} = 2.5V	500	540	580	mVp-p	D
	V _{OR}	R _{load} = 10KΩ, V _{DD} = 5.0V	510	560	600	mVp-p	D
Single Column Tone Output Amplitude	V _{OC}	R _{load} = 10KΩ, V _{DD} = 2.5V	620	680	730	mVp-p	D
	V _{OC}	R _{load} = 10KΩ, V _{DD} = 5.0V	650	710	760	mVp-p	D
Pre-emphasis	Twist		1	2	3	dB	D
Valley of Single Tone	V _V			V _{DD} -1.8	V _{DD} -1.6	V	sec
Distortion	DIS %	*(see note below)		1	5	%	D

*Note:

$$\text{DIS (\%)} = \frac{100 (V_1^2 + V_2^2 + \dots + V_n^2)^{1/2}}{(V_{IL}^2 + V_{IH}^2)^{1/2}}$$

where

- a) V₁...V_n are the intermodulation or harmonic frequencies in the 500 Hz to 3400 Hz band, and
 b) V_{IL} and V_{IH} are the individual frequency components of the DTMF signal.

 Tone/Pulse
Dialer

AC Characteristics

 (V_{DD} = 3.5 V, V_{SS} = 0. V, F_{OSC} = 480 KHz, T_{OP} = 25°C unless otherwise specified.)

Parameter	Symbol	Conditions	Min.	Typ.	Max.	Unit
PULSE						
Make/Break Ratio	M/B	M/B = V _{DD}		1/2		
		M/B = V _{SS}		2/3		
Dial Pulse Rate	DR	DRS = V _{DD}		20		PPS
		DRS = V _{SS}		10		
Make Time	T _M	10 PPS M/B = 1/2		33.3		ms
		10 PPS M/B = 2/3		40		
		20 PPS M/B = 1/2		16.7		
		20 PPS M/B = 2/3		20		
Break Time	T _B	10 PPS M/B = 1/2		66.7		ms
		10 PPS M/B = 2/3		60		
		20 PPS M/B = 1/2		33.3		
		20 PPS M/B = 2/3		30		
Inter-digit Pause Time	T _{IDP}	10 PPS M/B = 1/2		827		ms
		10 PPS M/B = 2/3		820		
		20 PPS M/B = 1/2		603		
		20 PPS M/B = 2/3		600		
Pre-digit Pause Time	T _{PDP}	10 PPS M/B = 1/2		830		ms
		10 PPS M/B = 2/3		830		
		20 PPS M/B = 1/2		620		
		20 PPS M/B = 2/3		620		
MUTE, DELAY, XMUTE Time	T _{MDP}	10 PPS M/B = 1/2		33.3		ms
		10 PPS M/B = 2/3		40		
		20 PPS M/B = 1/2		16.7		
		20 PPS M/B = 2/3		20		
TONE						
Minimum tone duration	T _{MFD}			100		ms
Minimum Tone Inter-digit Pause Time	T _{TIDP}			100		ms
Tone Output Pre-digit Pause Time	T _{RPDP}			0		ms
XMUTE Delay Time	T _{MDP}			100		ms
Access Pause Time	T _{AP}			4.26/2		sec
Oscillator Start-up Time	T _{START}			10		ms
MUTE, XMUTE Start-up Time	T _{MS}			28		ms
Keypad Debounce Time	T _{KD}			17		ms
Key Scan Frequency	F _{KS}	R1 ~ R5, C1 ~ C8		300		Hz
Flash Time	T _{FLASH}			600/100		ms
Pause Post Flash Time	T _{PPF}			1.6		sec

R/C	Conditions	Spec.	Actual	Error(%)	Unit
$\overline{R1}$	FOSC = 480 KHz	697	696.65	- 0.19	Hz
$\overline{R2}$		770	769.23	-0.1	Hz
$\overline{R3}$		852	851.06	-0.11	Hz
$\overline{R4}$		941	941.18	+0.02	Hz
$\overline{C1}$		1209	1212.12	+0.26	Hz
$\overline{C2}$		1336	1333.33	-0.2	Hz
$\overline{C3}$		1477	1481.48	+0.3	Hz

Pin Description

Pin	Designation	Description
11-14 17-20 22-26	$\overline{R0} \sim \overline{R4}$ $\overline{C1} \sim \overline{C8}$	Key inputs. A key operation is activated when the row and column corresponding to a particular key are connected. When the \overline{HK} pin is at V_{DD} level (see below), all row and column pins are in the high state and are at high impedance. When a key is depressed, the column input for that key is pulled high and the row output is pulled low; a scanning signal is present on the other row and column pins. Typical keyboard input debounce time is 22 ms.
21	\overline{HK}	Hook switch input. $\overline{HK} = V_{DD}$: on-hook state (device inactive). $\overline{HK} = V_{SS}$: off-hook state (device activated).
7	M/B	Dial pulse make/break ratio select input. M/B pin = V_{DD} : make/break ratio = 1:2 M/B pin = V_{SS} : make/break ratio = 2:3
10	DRS	Dialing rate select input. DRS = V_{DD} : dialing rate = 20 PPS DRS = V_{SS} : dialing rate = 10 PPS
1	MODE OUT	Mode output. N-channel open drain output. Output transistor is switched off in the on-hook state and when the dial pulse output mode is activated; switched on at all other times.
2	MUTE	Mute output. N-channel open drain output. Output transistor is switched on during pulse dialing sequence; switched off at all other times.
4	\overline{XMUTE}	Transmit mute output. N-channel open drain output. Output transistor is switched on during dialing sequence (both pulse and tone modes) and off at all other times.

Pin Description (Continued)

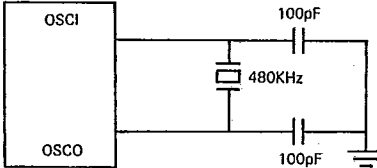
Pin	Designation	Description
3 15	V_{DD} V_{SS}	Positive power supply input (operating range 1.8 to 5.0 V). Negative power input.
5	\overline{DP}	Dial pulse output. N-channel open drain output. When in off-hook pulse mode, output is low during dial pulse "break" and "flash" operations. Output is "open" at all other times. The UM91270 provides an 820 ms IDP (inter-digit pause) when set at the 10 pps dial pulse rate and a 600 ms IDP when set at the 20 pps dial pulse rate.
6	TONE	DTMF signal output. Bipolar structure output. Typical equivalent output impedance: 1.5 K Ω Both normal dialing and redialing minimum tone and IDP durations are built-in.
8 9	OSCO OSCI	Oscillator circuit output and input. Complete oscillator circuit is formed by adding one 480 KHz ceramic resonator, two 100 PF serial loading capacitors across the oscillator output and input pins. Oscillator circuit is activated when the HK pin is low. When $V_{DD} = 3.0$ V, typical oscillator start-up time is 10 ms. 
16	PAGE	Page select input for reduced keyboard application. When input level to this pin = V_{SS} , the M1 to M20 keys correspond directly to the 20 repertory memories. When input level to this pin = V_{DD} , the M11 to M20 repertory memory locations replace the M1 to M10 memories on the M1 to M10 keys.
27	MODE SELECT	Tone/pulse mode select input. When mode select input = V_{DD} , pulse mode is activated. When mode select input = V_{SS} , tone mode is activated. During a pulse dialing sequence, switching this input from V_{DD} to V_{SS} will cause the UM91270 to insert a tone code and a pause code into its buffer memory automatically, then change the remaining digits entered to a tone signal. Once tone mode has been selected, changing the mode select input from V_{SS} to V_{DD} will not switch the UM91270 back to pulse mode again except by means of an on-hook operation. Pressing the first digit after the off-hook operation during tone mode causes two codes to be written into the buffer memory: the first is a tone code, the second a digit code.
28	STORE	Store mode switch control. Off-hook store mode is activated when store pin input = V_{DD} . When off-hook store mode has been activated, the UM91270 will not return to normal mode again until the store pin input level is changed from V_{DD} to V_{SS} . On-hook store mode is obtained via application circuits. This input level is directly related to the HOOK pin input via an application circuit.

Operational Procedures

Symbol Definitions:

- Dp = pulse digit (0 through 9).
- Dt = tone digit (0 through 9, *, #).
- Dg = pulse digit or tone digit.
- Mj = memory location (M1, M2, M3M20).
- ZiZiZi = conversation mode.
- O-O1 = off-hook.
- O-O1 = on-hook.
- ↗ = input level from low to high.
- ↘ = input level from high to low.

Recommended Operations:

- Normal dialing in tone mode:
O-O1; Dp.....Dp; ZiZiZi; O-O1.
- Normal dialing in pulse mode:
O-O1; Dt.....Dt; ZiZiZi; O-O1.
- Normal dialing in pulse to tone mode via the **[T]** key:
(T/P input hold on Vss level) O-O1; Dp.....Dp; **[T]** ;
Dt.....Dt; ZiZiZi; O-O1.
- Normal dialing in pulse to tone mode via T/P input:
O-O1; Dp.....Dp; T/P ↗; Dt.....Dt; ZiZiZi; O-O1.
(Note: In normal dialing mode, digits will be dialed out exactly if the total number of digits to be dialed is less than 32.)
- Redialing:
O-O1; **[R]** ; ZiZiZi; O-O1.
(Note: this operation activates the UM91270 to dial out the number contained in the buffer memory.)
- Repertory dialing for one number memory:
O-O1; Mj; ZiZiZi; O-O1.
- Repertory dialing for cascaded memory:
O-O1; Mj.....Mj; ZiZiZi; O-O1.
(Warning: No more than 32 digits should be entered into the cascaded memory. Overflow digits will be truncated and will not be dialed out.)
- Clearing buffer memory:
O-O1; **[C]** .
- Clearing number memories via the **[S]** key:
O-O1; **[S]** ; **[C]** ; Mj; (return to normal mode).
- Clearing number memories via the store switch/ **[C]** key:
O-O1; store switch ↗ ; **[C]** , Mj, **[C]** , Mj; store switch ↘ (return to normal mode).
(Note: The store switch input will latch the UM91270 in the

store mode unless the store switch is switched back to the normal mode.)

- Storing numbers to memories via the **[S]** key:
O-O1; **[S]** ; Dg...Dg; Mj; **[S]** Dg...Dg; Mj... (return to normal mode).
- Storing numbers to memories via the store switch:
O-O1; store switch ↗ ; Dg....Dg; Mj; Dg....Dg; Mj;; store switch ↘ (return to normal mode).
- Clearing input errors:
.....Dgx,.....Dgx; **[C]** ; Dg....Dg; Mj;..... (erroneous input digits Dgx will not be stored into the Mj repertory memory address).

Functional Description

N-channel open drain output- \overline{DP} , \overline{MUTE} , \overline{XMUTE} , \overline{MODE} OUT

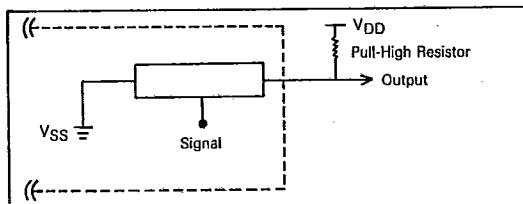

Figure 1.

DTMF Generator

The UM91270 has a well-designed DTMF output structure, with a 6 level, 12 segment stable reference voltage and a fixed output amplitude. This generator consists of a reference voltage regulator and a bipolar emitter follower that provides a $V_{DD}-1.8$ V reference voltage and an approximately 1.2 V tone output swing.

The UM91270's THD (total harmonic distortion) is 5% maximum when used under recommended conditions ($V_{DD} = 1.8$ V to 5.0 V, frequency between 500 and 3400 Hz).

The DTMF output signal (figure 2) and its output characteristics are shown in figures 3 and 4, "DTMF Signal THD vs. Operating Voltage" and "DTMF Output Amplitude vs. Operating Voltage"

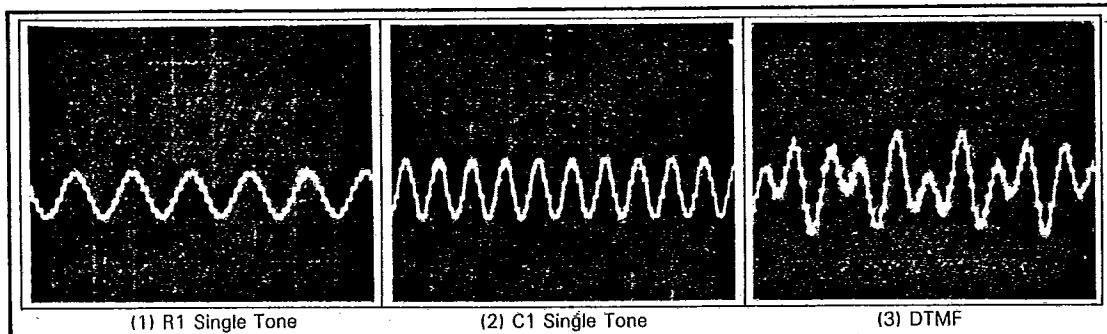

Figure 2. Waveforms
2-59

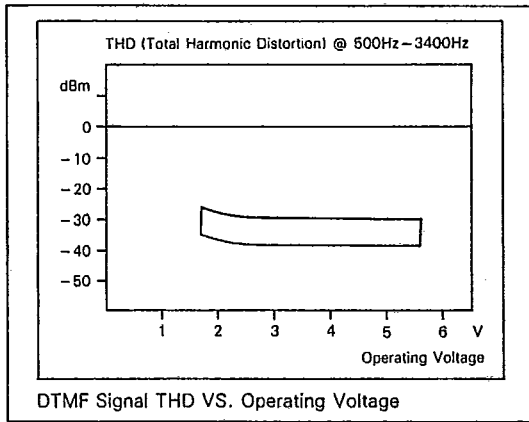

Figure 3.

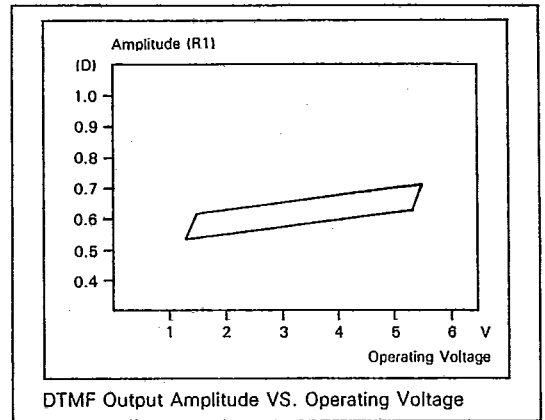
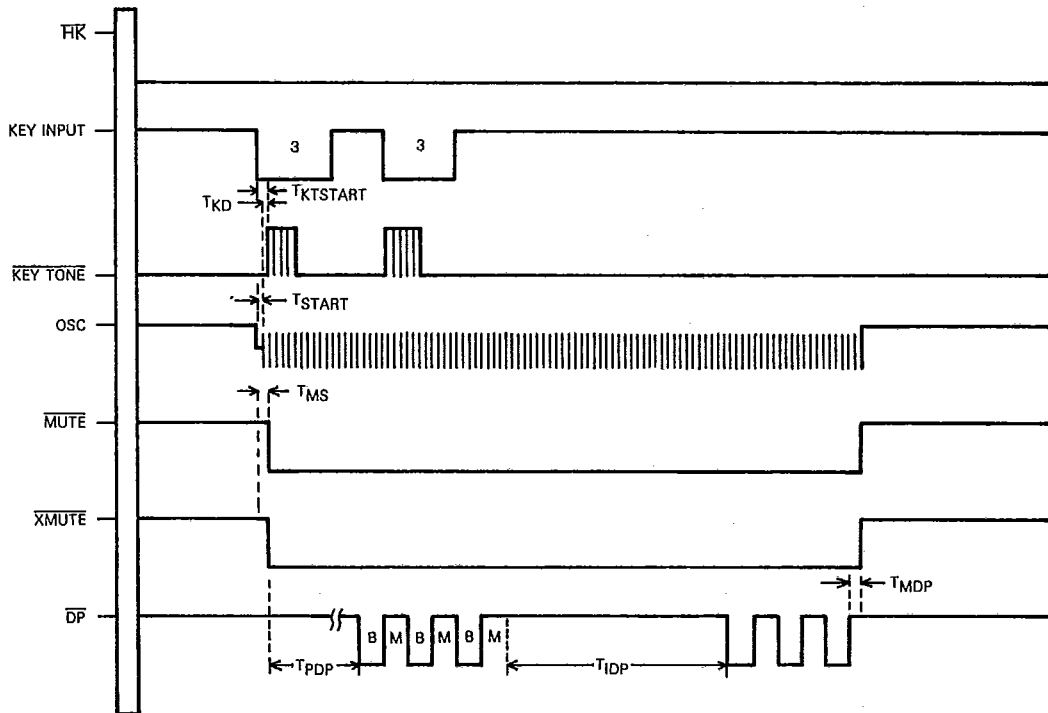
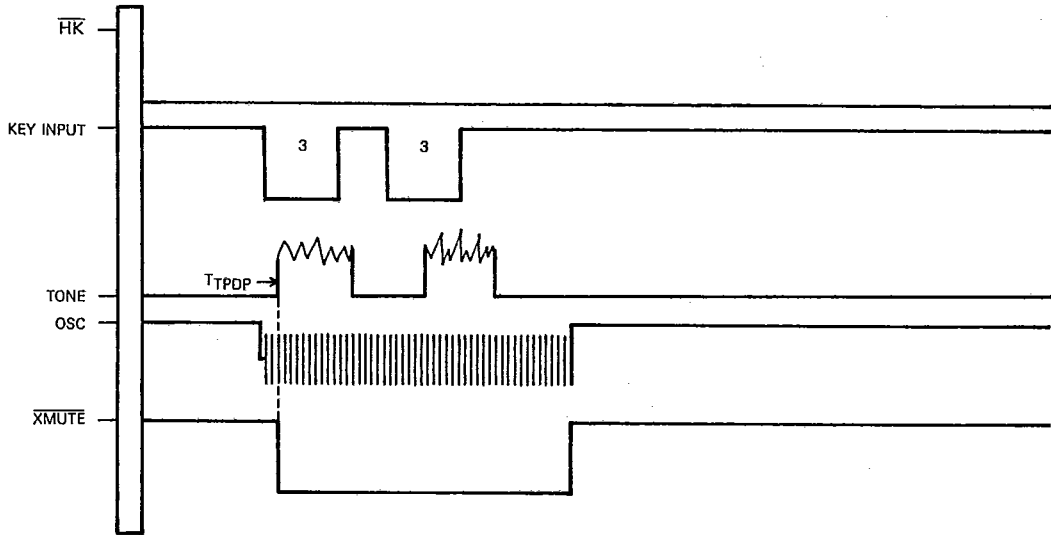
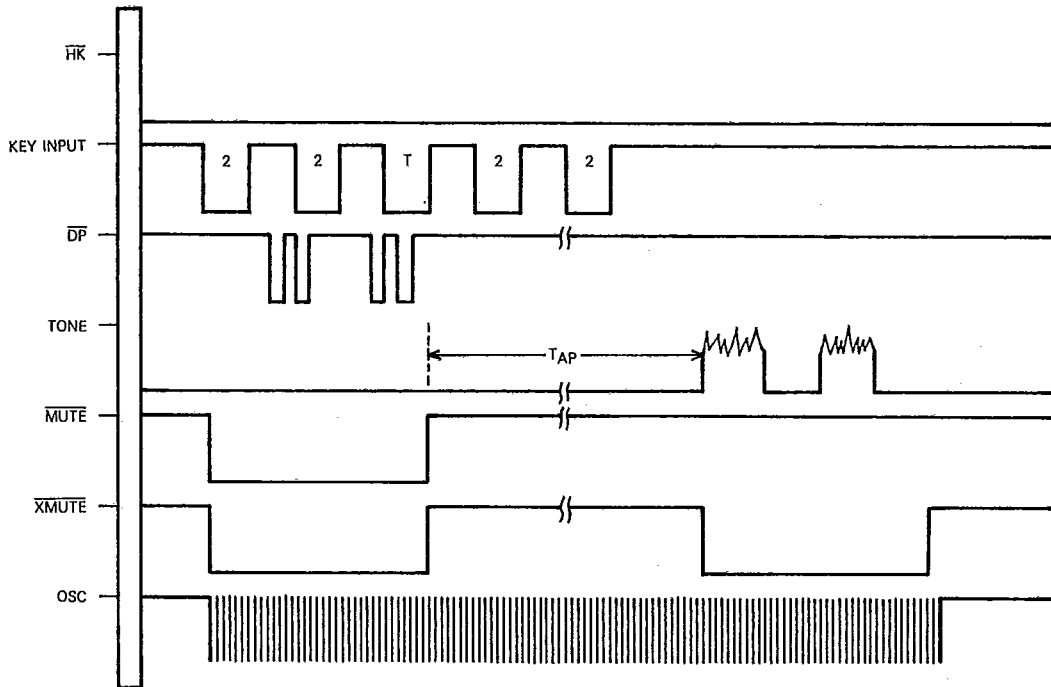

Figure 4.

Timing Diagrams
PULSE MODE TIMING DIAGRAM

TONE MODE TIMING DIAGRAM

Tone/Pulse
Dialer

NORMAL PULSE TO TONE MIXED DIALING VIA KEY

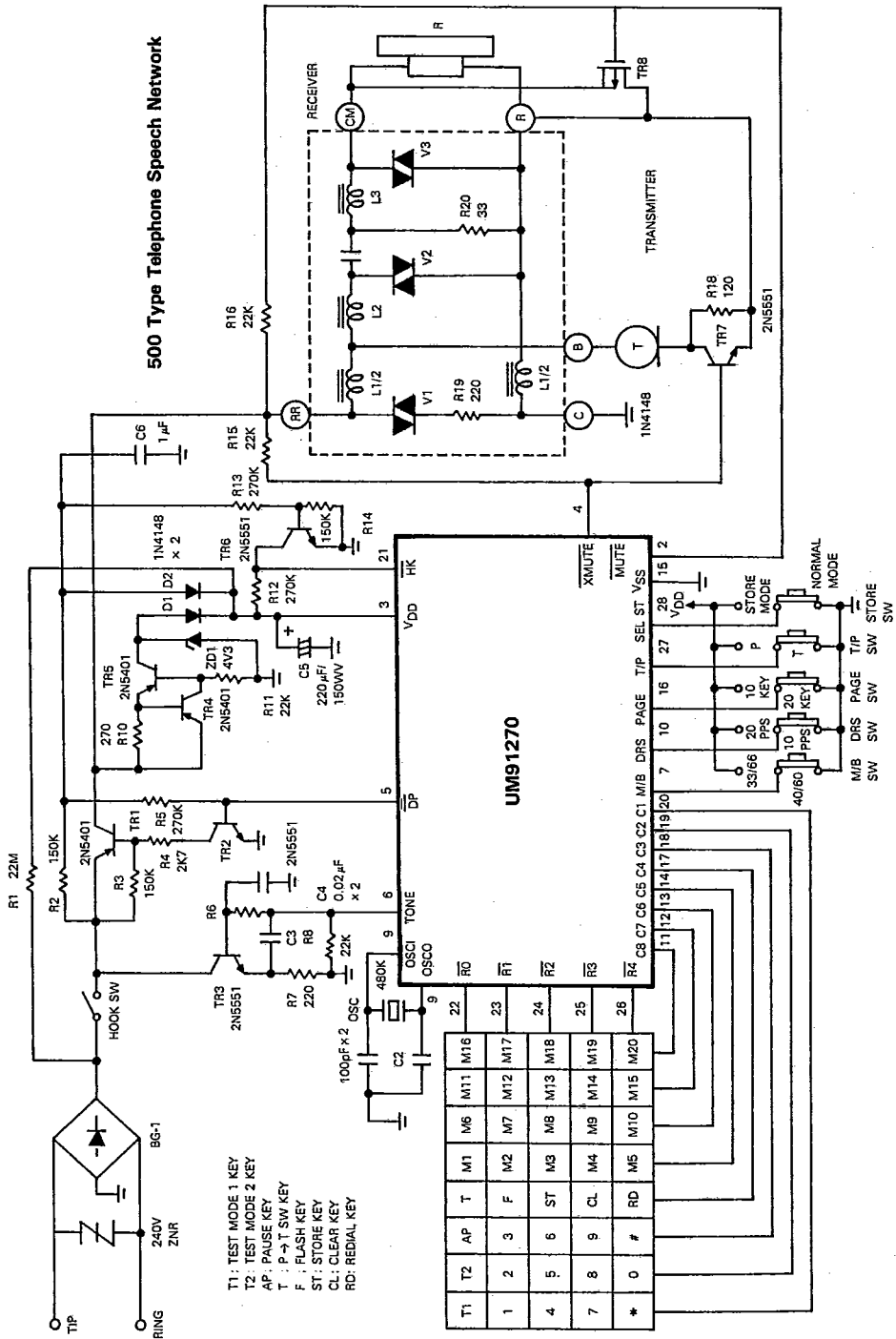
Typical Application Circuit

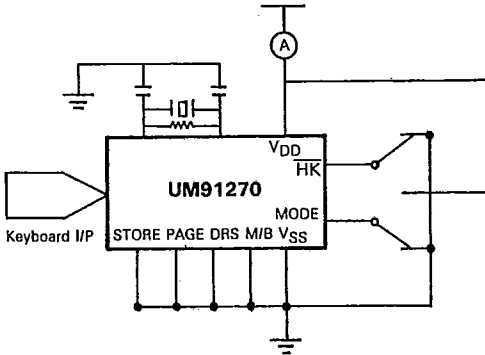
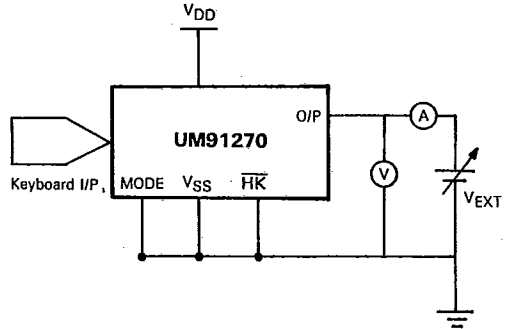
Test Circuits
(A)

(B)

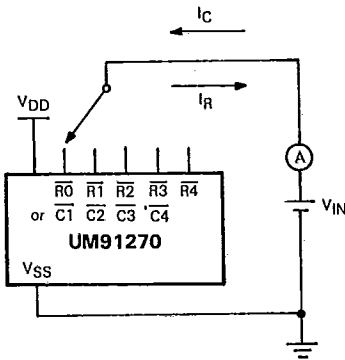
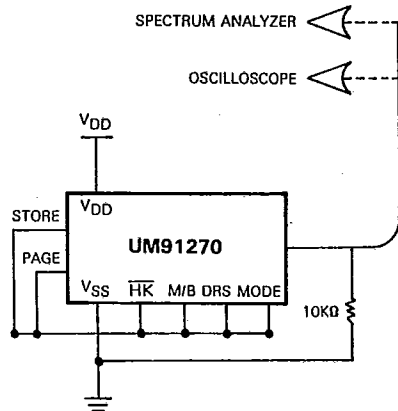
Tone/Pulse
Dialer

(C)

(D)

- * OSCILLOSCOPE: TEKTRONIX 468
- * SPECTRUM ANALYZER: HP 3585A