

**CP/M**

Software Manual

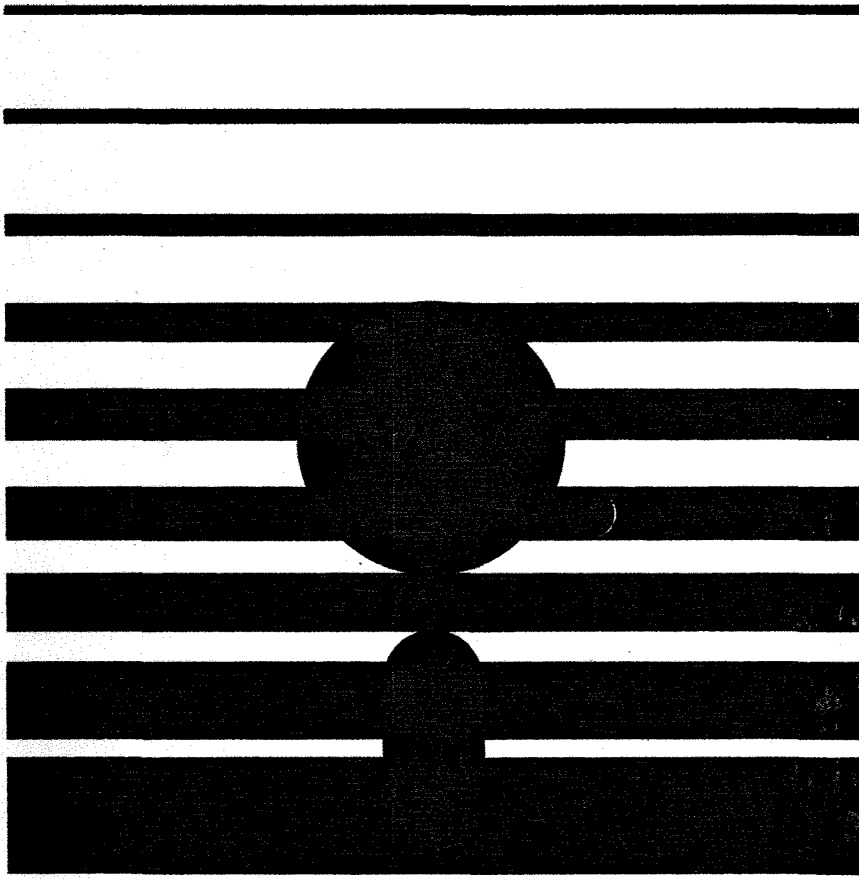

**EXIDY SYSTEMS**



1. The first part of the document  
describes the general situation  
of the country and the  
main problems that are  
facing it. It also  
mentions the main  
objectives of the  
policy and the  
main principles that  
will guide the  
implementation of the  
policy.

2. The second part of the document

describes the main  
measures that will be  
taken to achieve the  
objectives of the  
policy. It also  
mentions the main  
responsibilities of  
the different  
institutions and  
the main  
resources that will  
be used to  
implement the  
policy.

3. The third part of the document

describes the main  
measures that will be  
taken to monitor and  
evaluate the  
implementation of the  
policy. It also  
mentions the main  
responsibilities of  
the different  
institutions and  
the main  
resources that will  
be used to  
implement the  
policy.

4. The fourth part of the document  
describes the main  
measures that will be  
taken to ensure the  
sustainability of the  
policy. It also  
mentions the main  
responsibilities of  
the different  
institutions and  
the main  
resources that will  
be used to  
implement the  
policy.

## Table Of Contents

### CP/M 2.2

#### Section:

##### CP/M 2 User's Guide

1.	An Overview of CP/M 2.0 Facilities.....	1
2.	User Interface.....	3
3.	Console Command Processor (CCP) Interface..	4
4.	STAT Enhancements.....	5
5.	PIP Enhancements.....	8
6.	ED Enhancements.....	10
7.	The XSUB Function.....	11
8.	BDOS Interface Conventions.....	12
9.	CP/M 2.0 Memory Organization.....	27
10.	BIOS Differences.....	28

#### Section:

##### An Introduction To CP/M Features and Facilities

1.	Introduction.....	35
2.	Functional Description Of CP/M.....	37
	2.1 General Command Structure.....	37
	2.2 File References.....	37
3.	Switching Disks.....	40
4.	The Form Of Built-In Commands.....	41
	4.1 ERA afn cr.....	41
	4.2 DIR afn cr.....	42
	4.3 REN ufn1=ufn2 cr.....	42
	4.4 SAVE n ufn cr.....	43
	4.5 TYPE ufn cr.....	43
5.	Line Editing And Output Control.....	45
6.	Transient Commands.....	46
	6.1 STAT cr.....	47
	6.2 ASM ufn cr.....	50
	6.3 LOAD ufn cr.....	51
	6.4 PIP cr.....	52
	6.5 ED ufn cr.....	59
	6.6 SYSGEN cr.....	61
	6.7 SUBMIT ufn parm#1 parm#n cr.....	62
	6.8 DUMP ufn cr.....	64
	6.9 MOVCPM cr.....	64
7.	BDOS Error Messages.....	67
8.	Operation Of CP/M On The MDS.....	69

**Section:**

**CP/M Assembler (ASM): User's Guide**

1.	Introduction.....	71
2.	Program Format.....	72
3.	Forming The Operand.....	74
3.1	Labels.....	74
3.2	Numeric Constants.....	74
3.3	Reserved Words.....	75
3.4	String Constants.....	76
3.5	Arithmetic and Logical Operators.....	76
3.6	Precedence Of Operators.....	77
4.	Assembler Directives.....	78
4.1	The ORG Directive.....	78
4.2	The END Directive.....	79
4.3	The EQU Directive.....	79
4.4	The SET Directive.....	80
4.5	The IF And ENDIF Directives.....	80
4.6	The DB Directive.....	81
4.7	The DW Directive.....	82
5.	Operation Codes.....	82
5.1	Jumps, Calls And Returns.....	83
5.2	Immediate Operand Instructions.....	84
5.3	Increment and Decrement Instructions.....	84
5.4	Data Movement Instructions.....	84
5.5	Arithmetic Logic Unit Operations.....	85
5.6	Control Instructions.....	86
6.	Error Messages.....	86
7.	A Sample Session.....	87

**Section:**

**ED: A Content Editor For The CP/M Disk System:  
User's Manual**

1.	ED Tutorial.....	93
1.1	Introduction to ED.....	93
1.2	ED Operation.....	93
1.3	Text Transfer Functions.....	93
1.4	Memory Buffer Organization.....	97
1.5	Memory Buffer Operation.....	97
1.6	Command Strings.....	99
1.7	Text Search and Alteration.....	100
1.8	Source Libraries.....	103
1.9	Repetitive Command Execution.....	104
2.	ED Error Conditions.....	105
3.	Control Characters And Commands.....	106



Section:  
CP/M Debugging Tool (DDT): User's Guide

I.	Introduction.....	111
II.	DDT Commands.....	113
	1. The A (Assemble) Command.....	113
	2. The D (Display) Command.....	114
	3. The F (Fill) Command.....	114
	4. The G (Go) Command.....	114
	5. The I (Input) Command.....	115
	6. The L (List) Command.....	116
	7. The M (Move) Command.....	116
	8. The R (Read) Command.....	116
	9. The S (Set) Command.....	117
	10. The T (Trace) Command.....	117
	11. The U (Untrace) Command.....	118
	12. The X (Examine) Command.....	118
III.	Implementation Notes.....	119
IV.	An Example.....	120

Section:  
CP/M 2.2 Interface Guide

1.	Introduction.....	131
2.	Operating System Call Conventions.....	133
3.	A Sample File-To-File Copy Program.....	159
4.	A Sample File Dump Utility.....	164
5.	A Sample Random Access Program.....	167
6.	System Function Summary.....	176

Section:  
CP/M Alteration Guide

1.	Introduction.....	177
2.	First Level System Regenerative.....	178
3.	Second Level System Generation.....	182
4.	Sample Getsys And Putsys Programs.....	186
5.	Diskette Organization.....	188
6.	The BIOS Entry Points.....	190
7.	A Sample BIOS.....	197
8.	A Sample Cold Start Loader.....	198
9.	Reserved Locations In Page Zero.....	199
10.	Disk Parameter Tables.....	201
11.	The DISKDEF Macro Library.....	206
12.	Sector Blocking And Deblocking.....	210
	Appendix A.....	212
	Appendix B.....	215
	Appendix C.....	226
	Appendix D.....	232
	Appendix E.....	235
	Appendix F.....	237
	Appendix G.....	242

**Section:**

**Exidy Systems' CBIOS User's Guide:  
Version 1.0 For CP/M 2.2**

1.	Introduction.....	249
2.	Configuration and System Generation.....	251
	A. Hardware for the DDS and the FDS.....	251
	B. System Generation.....	252
	C. Options.....	253
	D. Incompatibilities.....	254
	E. Sector Skew Pattern.....	254
	F. Special Video Display Interface.....	255
3.	Features.....	256
	A. Error Recovery.....	256
	B. CP/M Programming.....	257
4.	Error Messages.....	259

**Section:**

**Exidy Systems' Excopy User's Guide: Version 2.0**

1.	Introduction.....	262
2.	Use.....	263
3.	Sample Run.....	264
	A. Excopy With Two Multiple Drives.....	264
	B. Excopy With One Drive.....	264
	C. Format Only.....	265
4.	Error Messages.....	266
	A. Can Not Format, Try Again.....	266
	B. Destination Is Write Protected.....	266
	C. Write Error On Track #XX.....	267
	D. Read Back Error On Track #XX.....	267
	E. Additional Messages.....	267
5.	Recovery.....	268

CP/M 2 USER'S GUIDE

## COPYRIGHT

Copyright (c) 1980 by Exidy Systems, Inc. All rights reserved. No part of this publication may be reproduced, transmitted, transcribed, stored in a retrieval system, or translated into any language, in any form or by any means, electronic, mechanical, magnetic, optical, chemical, manual, or otherwise, without the prior written permission of Exidy Systems, Inc., 1234 Elko Drive, Sunnyvale, California 94086.

Since this manual is tutorial in nature, permission is granted to reproduce or abstract the example procedures and sample programs for the purposes of inclusion within the reader's programs.

## DISCLAIMER

Exidy Systems, Inc. makes no representations or warranties with respect to the contents hereof and specifically disclaims any implied warranties of merchantability or fitness for any particular purpose. Further, Exidy Systems, Inc. reserves the right to revise this publication and to make changes from time to time in the content hereof without obligation of Exidy Systems, Inc. to notify any person of such revision or changes.

## TRADEMARKS

CP/M is a registered trademark of Digital Research.

100  
 101  
 102  
 103  
 104  
 105  
 106  
 107  
 108  
 109  
 110  
 111  
 112  
 113  
 114  
 115  
 116  
 117  
 118  
 119  
 120

**CP/M 2 USER'S GUIDE**

121  
 122  
 123  
 124  
 125  
 126  
 127  
 128  
 129  
 130

131

## COPYRIGHT

Copyright (c) 1980 by Exidy Systems, Inc. All rights reserved. No part of this publication may be reproduced, transmitted, transcribed, stored in a retrieval system, or translated into any language, in any form or by any means, electronic, mechanical, magnetic, optical, chemical, manual, or otherwise, without the prior written permission of Exidy Systems, Inc., 1234 Elko Drive, Sunnyvale, California 94086.

Since this manual is tutorial in nature, permission is granted to reproduce or abstract the example procedures and sample programs for the purposes of inclusion within the reader's programs.

## DISCLAIMER

Exidy Systems, Inc. makes no representations or warranties with respect to the contents hereof and specifically disclaims any implied warranties of merchantability or fitness for any particular purpose. Further, Exidy Systems, Inc. reserves the right to revise this publication and to make changes from time to time in the content hereof without obligation of Exidy Systems, Inc. to notify any person of such revision or changes.

## TRADEMARKS

CP/M is a registered trademark of Digital Research.

## CP/M 2 USER'S GUIDE

Copyright (c) 1979  
Digital Research, Box 579  
Pacific Grove, California

1. An Overview of CP/M 2.0 Facilities . . . . .	1
2. User Interface . . . . .	3
3. Console Command Processor (CCP) Interface . . . . .	4
4. STAT Enhancements . . . . .	5
5. PIP Enhancements . . . . .	8
6. ED Enhancements . . . . .	10
7. The XSUB Function . . . . .	11
8. BDOS Interface Conventions . . . . .	12
9. CP/M 2.0 Memory Organization . . . . .	27
10. BIOS Differences . . . . .	28





## 1. AN OVERVIEW OF CP/M 2.0 FACILITIES.

CP/M 2.0 is a high-performance single-console operating system which uses table driven techniques to allow field reconfiguration to match a wide variety of disk capacities. All of the fundamental file restrictions are removed, while maintaining upward compatibility from previous versions of release 1. Features of CP/M 2.0 include field specification of one to sixteen logical drives, each containing up to eight megabytes. Any particular file can reach the full drive size with the capability to expand to thirty-two megabytes in future releases. The directory size can be field configured to contain any reasonable number of entries, and each file is optionally tagged with read/only and system attributes. Users of CP/M 2.0 are physically separated by user numbers, with facilities for file copy operations from one user area to another. Powerful relative-record random access functions are present in CP/M 2.0 which provide direct access to any of the 65536 records of an eight megabyte file.

All disk-dependent portions of CP/M 2.0 are placed into a BIOS-resident "disk parameter block" which is either hand coded or produced automatically using the disk definition macro library provided with CP/M 2.0. The end user need only specify the maximum number of active disks, the starting and ending sector numbers, the data allocation size, the maximum extent of the logical disk, directory size information, and reserved track values. The macros use this information to generate the appropriate tables and table references for use during CP/M 2.0 operation. Deblocking information is also provided which aids in assembly or disassembly of sector sizes which are multiples of the fundamental 128 byte data unit, and the system alteration manual includes general-purpose subroutines which use the this deblocking information to take advantage of larger sector sizes. Use of these subroutines, together with the table driven data access algorithms, make CP/M 2.0 truly a universal data management system.

File expansion is achieved by providing up to 512 logical file extents, where each logical extent contains 16K bytes of data. CP/M 2.0 is structured, however, so that as much as 128K bytes of data is addressed by a single physical extent (corresponding to a single directory entry), thus maintaining compatibility with previous versions while taking full advantage of directory space.

Random access facilities are present in CP/M 2.0 which allow immediate reference to any record of an eight megabyte file. Using CP/M's unique data organization, data blocks are only allocated when actually required and movement to a record position requires little search time. Sequential file access is upward compatible from earlier versions to the full eight megabytes, while random access compatibility stops at 512K byte files. Due to CP/M 2.0's simpler and faster random access, application programmers are encouraged to alter their programs to take full advantage of the 2.0 facilities.

Several CP/M 2.0 modules and utilities have improvements which correspond to the enhanced file system. STAT and PIP both account for file attributes and user areas, while the CCP provides a "login"

(All Information Contained Herein is Proprietary to Digital Research.)

function to change from one user area to another. The CCP also formats directory displays in a more convenient manner and accounts for both CRT and hard-copy devices in its enhanced line editing functions.

The sections below point out the individual differences between CP/M 1.4 and CP/M 2.0, with the understanding that the reader is either familiar with CP/M 1.4, or has access to the 1.4 manuals. Additional information dealing with CP/M 2.0 I/O system alteration is presented in the Digital Research manual "CP/M 2.0 Alteration Guide."

(All Information Contained Herein is Proprietary to Digital Research.)

## 2. USER INTERFACE.

Console line processing takes CRT-type devices into account with three new control characters, shown with an asterisk in the list below (the symbol "ctl" below indicates that the control key is simultaneously depressed):

```
rub/del removes and echoes last character
ctl-C  reboot when at beginning of line
ctl-E  physical end of line
ctl-H  backspace one character position*
ctl-J  (line feed) terminates current input*
ctl-M  (carriage return) terminates input
ctl-R  retype current line after new line
ctl-U  remove current line after new line
ctl-X  backspace to beginning of current line*
```

In particular, note that ctl-H produces the proper backspace overwrite function (ctl-H can be changed internally to another character, such as delete, through a simple single byte change). Further, the line editor keeps track of the current prompt column position so that the operator can properly align data input following a ctl-U, ctl-R, or ctl-X command.

### 3. CONSOLE COMMAND PROCESSOR (CCP) INTERFACE.

There are four functional differences between CP/M 1.4 and CP/M 2.0 at the console command processor (CCP) level. The CCP now displays directory information across the screen (four elements per line), the USER command is present to allow maintenance of separate files in the same directory, and the actions of the "ERA \*.\*" and "SAVE" commands have changed. The altered DIR format is self-explanatory, while the USER command takes the form:

USER n

where n is an integer value in the range 0 to 15. Upon cold start, the operator is automatically "logged" into user area number 0, which is compatible with standard CP/M 1.4 directories. The operator may issue the USER command at any time to move to another logical area within the same directory. Drives which are logged-in while addressing one user number are automatically active when the operator moves to another user number since a user number is simply a prefix which accesses particular directory entries on the active disks.

The active user number is maintained until changed by a subsequent USER command, or until a cold start operation when user 0 is again assumed.

Due to the fact that user numbers now tag individual directory entries, the ERA \*.\* command has a different effect. In version 1.4, this command can be used to erase a directory which has "garbage" information, perhaps resulting from use of a diskette under another operating system (heaven forbid!). In 2.0, however, the ERA \*.\* command affects only the current user number. Thus, it is necessary to write a simple utility to erase a nonsense disk (the program simply writes the hexadecimal pattern E5 throughout the disk).

The SAVE command in version 1.4 allows only a single memory save operation, with the potential of destroying the memory image due to directory operations following extent boundary changes. Version 2.0, however, does not perform directory operations in user data areas after disk writes, and thus the SAVE operation can be used any number of times without altering the memory image.

#### 4. STAT ENHANCEMENTS.

The STAT program has a number of additional functions which allow disk parameter display, user number display, and file indicator manipulation. The command:

STAT VAL:

produces a summary of the available status commands, resulting in the output:

```
Temp R/O Disk: d:=R/O
Set Indicator: d:filename.typ $R/O $R/W $SYS $DIR
Disk Status   : DSK: d:DSK:
User Status   :USR:
Iobyte Assign:
(list of possible assignments)
```

which gives an instant summary of the possible STAT commands. The command form:

STAT d:filename.typ \$\$

where "d:" is an optional drive name, and "filename.typ" is an unambiguous or ambiguous file name, produces the output display format:

Size	Recs	Bytes	Ext	Acc
48	48	6k	1	R/O A:ED.COM
55	55	12k	1	R/O (A:PIP.COM)
65536	128	2k	2	R/W A:X.DAT

where the \$\$ parameter causes the "Size" field to be displayed (without the \$\$, the Size field is skipped, but the remaining fields are displayed). The Size field lists the virtual file size in records, while the "Recs" field sums the number of virtual records in each extent. For files constructed sequentially, the Size and Recs fields are identical. The "Bytes" field lists the actual number of bytes allocated to the corresponding file. The minimum allocation unit is determined at configuration time, and thus the number of bytes corresponds to the record count plus the remaining unused space in the last allocated block for sequential files. Random access files are given data areas only when written, so the Bytes field contains the only accurate allocation figure. In the case of random access, the Size field gives the logical end-of-file record position and the Recs field counts the logical records of each extent (each of these extents, however, may contain unallocated "holes" even though they are added into the record count). The "Ext" field counts the number of logical 16K extents allocated to the file. Unlike version 1.4, the Ext count does not necessarily correspond to the number of directory entries given to the file, since there can be up to 128K bytes (8 logical extents) directly addressed by a single directory entry, depending upon allocation size (in a special case, there are actually 256K bytes which can be directly addressed by a physical extent).

The "Acc" field gives the R/O or R/W access mode, which is changed using the commands shown below. Similarly, the parentheses

(All Information Contained Herein is Proprietary to Digital Research.)

shown around the PIP.COM file name indicate that it has the "system" indicator set, so that it will not be listed in DIR commands. The four command forms

```
STAT d:filename.typ $R/O
STAT d:filename.typ $R/W
STAT d:filename.typ $SYS
STAT d:filename.typ $DIR
```

set or reset various permanent file indicators. The R/O indicator places the file (or set of files) in a read-only status until changed by a subsequent STAT command. The R/O status is recorded in the directory with the file so that it remains R/O through intervening cold start operations. The R/W indicator places the file in a permanent read/write status. The SYS indicator attaches the system indicator to the file, while the DIR command removes the system indicator. The "filename.typ" may be ambiguous or unambiguous, but in either case, the files whose attributes are changed are listed at the console when the change occurs. The drive name denoted by "d:" is optional.

When a file is marked R/O, subsequent attempts to erase or write into the file result in a terminal BDOS message

```
Bdos Err on d: File R/O
```

The BDOS then waits for a console input before performing a subsequent warm start (a "return" is sufficient to continue). The command form

```
STAT d:DSK:
```

lists the drive characteristics of the disk named by "d:" which is in the range A:, B:, ..., P:. The drive characteristics are listed in the format:

```
d: Drive Characteristics
65536: 128 Byte record Capacity
8192: Kilobyte Drive Capacity
128: 32 Byte Directory Entries
0: Checked Directory Entries
1024: Records/ Extent
128: Records/ Block
58: Sectors/ Track
2: Reserved Tracks
```

where "d:" is the selected drive, followed by the total record capacity (65536 is an 8 megabyte drive), followed by the total capacity listed in Kilobytes. The directory size is listed next, followed by the "checked" entries. The number of checked entries is usually identical to the directory size for removable media, since this mechanism is used to detect changed media during CP/M operation without an intervening warm start. For fixed media, the number is usually zero, since the media is not changed without at least a cold or warm start. The number of records per extent determines the addressing capacity of each directory entry (1024 times 128 bytes, or

(All Information Contained Herein is Proprietary to Digital Research.)

128K in the example above). The number of records per block shows the basic allocation size (in the example, 128 records/block times 128 bytes per record, or 16K bytes per block). The listing is then followed by the number of physical sectors per track and the number of reserved tracks. For logical drives which share the same physical disk, the number of reserved tracks may be quite large, since this mechanism is used to skip lower-numbered disk areas allocated to other logical disks. The command form

STAT DSK:

produces a drive characteristics table for all currently active drives. The final STAT command form is

STATUSR:

which produces a list of the user numbers which have files on the currently addressed disk. The display format is:

```
Active User : 0
Active Files: 0 1 3
```

where the first line lists the currently addressed user number, as set by the last CCP USER command, followed by a list of user numbers scanned from the current directory. In the above case, the active user number is 0 (default at cold start), with three user numbers which have active files on the current disk. The operator can subsequently examine the directories of the other user numbers by logging-in with USER 1, USER 2, or USER 3 commands, followed by a DIR command at the CCP level.

## 5. PIP ENHANCEMENTS.

PIP provides three new functions which account for the features of CP/M 2.0. All three functions take the form of file parameters which are enclosed in square brackets following the appropriate file names. The commands are:

Gn	Get File from User number n (n in the range 0 - 15)
W	Write over R/O files without console interrogation
R	Read system files

The G command allows one user area to receive data files from another. Assuming the operator has issued the USER 4 command at the CCP level, the PIP statement

```
PIP X.Y = X.Y[G2]
```

reads file X.Y from user number 2 into user area number 4. The command

```
PIP A:=A:*.*[G2]
```

copies all of the files from the A drive directory for user number 2 into the A drive directory of the currently logged user number. Note that to ensure file security, one cannot copy files into a different area than the one which is currently addressed by the USER command.

Note also that the PIP program itself is initially copied to a user area (so that subsequent files can be copied) using the SAVE command. The sequence of operations shown below effectively moves PIP from one user area to the next.

```
USER 0          login user 0
DDT PIP.COM     load PIP to memory
                (note PIP size s)
G0             return to CCP
USER 3          login user 3
SAVE s PIP.COM
```

where s is the integral number of memory "pages" (256 byte segments) occupied by PIP. The number s can be determined when PIP.COM is loaded under DDT, by referring to the value under the "NEXT" display. If for example, the next available address is 1D00, then PIP.COM requires 1C hexadecimal pages (or 1 times 16 + 12 = 28 pages), and thus the value of s is 28 in the subsequent save. Once PIP is copied in this manner, it can then be copied to another disk belonging to the same user number through normal pip transfers.

Under normal operation, PIP will not overwrite a file which is set to a permanent R/O status. If attempt is made to overwrite a R/O file, the prompt

(All Information Contained Herein is Proprietary to Digital Research.)



DESTINATION FILE IS R/O, DELETE (Y/N)?

is issued. If the operator responds with the character "y" then the file is overwritten. Otherwise, the response

**\*\* NOT DELETED \*\***

is issued, the file transfer is skipped, and PIP continues with the next operation in sequence. In order to avoid the prompt and response in the case of R/O file overwrite, the command line can include the W parameter, as shown below

PIP A:=B:\*.COM[W]

which copies all non-system files to the A drive from the B drive, and overwrites any R/O files in the process. If the operation involves several concatenated files, the W parameter need only be included with the last file in the list, as shown in the following example

PIP A.DAT = B.DAT,F:NEW.DAT,G:OLD.DAT[W]

Files with the system attribute can be included in PIP transfers if the R parameter is included, otherwise system files are not recognized. The command line

PIP ED.COM = B:ED.COM[R]

for example, reads the ED.COM file from the B drive, even if it has been marked as a R/O and system file. The system file attributes are copied, if present.

It should be noted that downward compatibility with previous versions of CP/M is only maintained if the file does not exceed one megabyte, no file attributes are set, and the file is created by user 0. If compatibility is required with non-standard (e.g., "double density") versions of 1.4, it may be necessary to select 1.4 compatibility mode when constructing the internal disk parameter block (see the "CP/M 2.0 Alteration Guide," and refer to Section 10 which describes BIOS differences).

(All Information Contained Herein is Proprietary to Digital Research.)

## 6. ED ENHANCEMENTS.

The CP/M standard program editor provides several new facilities in the 2.0 release. Experience has shown that most operators use the relative line numbering feature of ED, and thus the editor has the "v" (Verify Line) option set as an initial value. The operator can, of course, disable line numbering by typing the "-v" command. If you are not familiar with the ED line number mode, you may wish to refer to the Appendix in the ED user's guide, where the "v" command is described.

ED also takes file attributes into account. If the operator attempts to edit a read/only file, the message

```
** FILE IS READ/ONLY **
```

appears at the console. The file can be loaded and examined, but cannot be altered in any way. Normally, the operator simply ends the edit session, and uses STAT to change the file attribute to R/W. If the edited file has the "system" attribute set, the message

```
"SYSTEM" FILE NOT ACCESSIBLE
```

is displayed at the console, and the edit session is aborted. Again, the STAT program can be used to change the system attribute, if desired.

Finally, the insert mode ("i") command allows CRT line editing functions, as described in Section 2, above.

## 7. THE XSUB FUNCTION.

An additional utility program is supplied with version 2.0 of CP/M, called XSUB, which extends the power of the SUBMIT facility to include line input to programs as well as the console command processor. The XSUB command is included as the first line of your submit file and, when executed, self-relocates directly below the CCP. All subsequent submit command lines are processed by XSUB, so that programs which read buffered console input (BDOS function 10) receive their input directly from the submit file. For example, the file SAVER.SUB could contain the submit lines:

```
XSUB
DDT
I$1.HEX
R
G0
SAVE 1 $2.COM
```

with a subsequent SUBMIT command:

```
SUBMIT SAVER X Y
```

which substitutes X for \$1 and Y for \$2 in the command stream. The XSUB program loads, followed by DDT which is sent the command lines "IX.HEX" "R" and "G0" thus returning to the CCP. The final command "SAVE 1 Y.COM" is processed by the CCP.

The XSUB program remains in memory, and prints the message

```
(xsub active)
```

on each warm start operation to indicate its presence. Subsequent submit command streams do not require the XSUB, unless an intervening cold start has occurred. Note that XSUB must be loaded after DESPOOL, if both are to run simultaneously.

## 8. BDOS INTERFACE CONVENTIONS.

CP/M 2.0 system calls take place in exactly the same manner as earlier versions, with a call to location 0005H, function number in register C, and information address in register pair DE. Single byte values are returned in register A, with double byte values returned in HL (for reasons of compatibility, register A = L and register B = H upon return in all cases). A list of CP/M 2.0 calls is given below, with an asterisk following functions which are either new or revised from version 1.4 to 2.0. Note that a zero value is returned for out-of range function numbers.

0	System Reset	19*	Delete File
1	Console Input	20	Read Sequential
2	Console Output	21	Write Sequential
3	Reader Input	22*	Make File
4	Punch Output	23*	Rename File
5	List Output	24*	Return Login Vector
6*	Direct Console I/O	25	Return Current Disk
7	Get I/O Byte	26	Set DMA Address
8	Set I/O Byte	27	Get Addr(Alloc)
9	Print String	28*	Write Protect Disk
10*	Read Console Buffer	29*	Get Addr(R/O Vector)
11	Get Console Status	30*	Set File Attributes
12*	Return Version Number	31*	Get Addr(Disk Parms)
13	Reset Disk System	32*	Set/Get User Code
14	Select Disk	33*	Read Random
15*	Open File	34*	Write Random
16	Close File	35*	Compute File Size
17*	Search for First	36*	Set Random Record
18*	Search for Next		

(Functions 28, 29, and 32 should be avoided in application programs to maintain upward compatibility with MP/M.) The new or revised functions are described below.

### Function 6: Direct Console I/O.

Direct Console I/O is supported under CP/M 2.0 for those applications where it is necessary to avoid the BDOS console I/O operations. Programs which currently perform direct I/O through the BIOS should be changed to use direct I/O under BDOS so that they can be fully supported under future releases of MP/M and CP/M.

Upon entry to function 6, register E either contains hexadecimal FF, denoting a console input request, or register E contains an ASCII character. If the input value is FF, then function 6 returns A = 00 if no character is ready, otherwise A contains the next console input character.

If the input value in E is not FF, then function 6 assumes that E contains a valid ASCII character which is sent to the console.

(All Information Contained Herein is Proprietary to Digital Research.)

### Function 10: Read Console Buffer.

The console buffer read operation remains unchanged except that console line editing is supported, as described in Section 2. Note also that certain functions which return the carriage to the leftmost position (e.g., `ctl-X`) do so only to the column position where the prompt ended (previously, the carriage returned to the extreme left margin). This new convention makes operator data input and line correction more legible.

### Function 12: Return Version Number.

Function 12 has been redefined to provide information which allows version-independent programming (this was previously the "lift head" function which returned `HL=0000` in version 1.4, but performed no operation). The value returned by function 12 is a two-byte value, with `H = 00` for the CP/M release (`H = 01` for MP/M), and `L = 00` for all releases previous to 2.0. CP/M 2.0 returns a hexadecimal 20 in register L, with subsequent version 2 releases in the hexadecimal range 21, 22, through 2F. Using function 12, for example, you can write application programs which provide both sequential and random access functions, with random access disabled when operating under early releases of CP/M.

In the file operations described below, DE addresses a file control block (FCB). Further, all directory operations take place in a reserved area which does not affect write buffers as was the case in version 1.4, with the exception of Search First and Search Next, where compatibility is required.

The File Control Block (FCB) data area consists of a sequence of 33 bytes for sequential access, and a series of 36 bytes in the case that the file is accessed randomly. The default file control block normally located at `005CH` can be used for random access files, since bytes `007DH`, `007EH`, and `007FH` are available for this purpose. For notational purposes, the FCB format is shown with the following fields:

```

-----
|dr|f1|f2|/ /|f8|t1|t2|t3|ex|s1|s2|rc|d0|/ /|dn|cr|r0|r1|r2|
-----
00 01 02 ... 08 09 10 11 12 13 14 15 16 ... 31 32 33 34 35

```

where

dr           drive code (0 - 16)  
0 => use default drive for file  
1 => auto disk select drive A,  
2 => auto disk select drive B,  
...  
16=> auto disk select drive P.

f1...f8      contain the file name in ASCII  
upper case, with high bit = 0

t1,t2,t3     contain the file type in ASCII  
upper case, with high bit = 0  
t1', t2', and t3' denote the  
bit of these positions,  
t1' = 1 => Read/Only file,  
t2' = 1 => SYS file, no DIR list

ex           contains the current extent number,  
normally set to 00 by the user, but  
in range 0 - 31 during file I/O

s1           reserved for internal system use

s2           reserved for internal system use, set  
to zero on call to OPEN, MAKE, SEARCH

rc           record count for extent "ex,"  
takes on values from 0 - 128

d0...dn     filled-in by CP/M, reserved for  
system use

cr           current record to read or write in  
a sequential file operation, normally  
set to zero by user

r0,r1,r2     optional random record number in the  
range 0-65535, with overflow to r2,  
r0,r1 constitute a 16-bit value with  
low byte r0, and high byte r1

#### Function 15: Open File.

The Open File operation is identical to previous definitions, with the exception that byte s2 is automatically zeroed. Note that previous versions of CP/M defined this byte as zero, but made no

(All Information Contained Herein is Proprietary to Digital Research.)

checks to assure compliance. Thus, the byte is cleared to ensure upward compatibility with the latest version, where it is required.

#### Function 17: Search for First.

Search First scans the directory for a match with the file given by the FCB addressed by DE. The value 255 (hexadecimal FF) is returned if the file is not found, otherwise a value of A equal to 0, 1, 2, or 3 is returned indicating the file is present. In the case that the file is found, the current DMA address is filled with the record containing the directory entry, and the relative starting position is  $A * 32$  (i.e., rotate the A register left 5 bits, or ADD A five times). Although not normally required for application programs, the directory information can be extracted from the buffer at this position.

An ASCII question mark (63 decimal, 3F hexadecimal) in any position from fl through ex matches the corresponding field of any directory entry on the default or auto-selected disk drive. If the dr field contains an ASCII question mark, then the auto disk select function is disabled, the default disk is searched, with the search function returning any matched entry, allocated or free, belonging to any user number. This latter function is not normally used by application programs, but does allow complete flexibility to scan all current directory values. If the dr field is not a question mark, the s2 byte is automatically zeroed.

#### Function 18: Search for Next.

The Search Next function is similar to the Search First function, except that the directory scan continues from the last matched entry. Similar to function 17, function 18 returns the decimal value 255 in A when no more directory items match.

#### Function 19: Delete File.

The Delete File function removes files which match the FCB addressed by DE. The filename and type may contain ambiguous references (i.e., question marks in various positions), but the drive select code cannot be ambiguous, as in the Search and Search Next functions.

Function 19 returns a decimal 255 if the reference file or files could not be found, otherwise a value in the range 0 to 3 is returned.

(All Information Contained Herein is Proprietary to Digital Research.)

#### Function 22: Make File.

The Make File operation is identical to previous versions of CP/M, except that byte s2 is zeroed upon entry to the BDOS.

#### Function 23: Rename File.

The Actions of the file rename functions are the same as previous releases except that the value 255 is returned if the rename function is unsuccessful (the file to rename could not be found), otherwise a value in the range 0 to 3 is returned.

#### Function 24: Return Login Vector.

The login vector value returned by CP/M 2.0 is a 16-bit value in HL, where the least significant bit of L corresponds to the first drive A, and the high order bit of H corresponds to the sixteenth drive, labelled P. Note that compatibility is maintained with earlier releases, since registers A and L contain the same values upon return.

#### Function 28: Write Protect Current Disk.

The disk write protect function provides temporary write protection for the currently selected disk. Any attempt to write to the disk, before the next cold or warm start operation produces the message

Bdos Err on d: R/O

#### Function 29: Get R/O Vector.

Function 29 returns a bit vector in register pair HL which indicates drives which have the temporary read/only bit set. Similar to function 24, the least significant bit corresponds to drive A, while the most significant bit corresponds to drive P. The R/O bit is set either by an explicit call to function 28, or by the automatic software mechanisms within CP/M which detect changed disks.

#### Function 30: Set File Attributes.

The Set File Attributes function allows programmatic manipulation of permanent indicators attached to files. In particular, the R/O and System attributes (t1' and t2' above) can be set or reset. The DE pair addresses an unambiguous file name with the appropriate attributes set or reset. Function 30 searches for a

(All Information Contained Herein is Proprietary to Digital Research.)



match, and changes the matched directory entry to contain the selected indicators. Indicators f1' through f4' are not presently used, but may be useful for applications programs, since they are not involved in the matching process during file open and close operations. Indicators f5' through f8' and t3' are reserved for future system expansion.

#### Function 31: Get Disk Parameter Block Address.

The address of the BIOS resident disk parameter block is returned in HL as a result of this function call. This address can be used for either of two purposes. First, the disk parameter values can be extracted for display and space computation purposes, or transient programs can dynamically change the values of current disk parameters when the disk environment changes, if required. Normally, application programs will not require this facility.

#### Function 32: Set or Get User Code.

An application program can change or interrogate the currently active user number by calling function 32. If register E = FF hexadecimal, then the value of the current user number is returned in register A, where the value is in the range 0 to 31. If register E is not FF, then the current user number is changed to the value of E (modulo 32).

#### Function 33: Read Random.

The Read Random function is similar to the sequential file read operation of previous releases, except that the read operation takes place at a particular record number, selected by the 24-bit value constructed from the three byte field following the FCB (byte positions r0 at 33, r1 at 34, and r2 at 35). Note that the sequence of 24 bits is stored with least significant byte first (r0), middle byte next (r1), and high byte last (r2). CP/M release 2.0 does not reference byte r2, except in computing the size of a file (function 35). Byte r2 must be zero, however, since a non-zero value indicates overflow past the end of file.

Thus, in version 2.0, the r0,r1 byte pair is treated as a double-byte, or "word" value, which contains the record to read. This value ranges from 0 to 65535, providing access to any particular record of the 8 megabyte file. In order to process a file using random access, the base extent (extent 0) must first be opened. Although the base extent may or may not contain any allocated data, this ensures that the file is properly recorded in the directory, and is visible in DIR requests. The selected record number is then stored into the random record field (r0,r1), and the BDOS is called to read the record. Upon return from the call, register A either contains an

(All Information Contained Herein is Proprietary to Digital Research.)

error code, as listed below, or the value 00 indicating the operation was successful. In the latter case, the current DMA address contains the randomly accessed record. Note that contrary to the sequential read operation, the record number is not advanced. Thus, subsequent random read operations continue to read the same record.

Upon each random read operation, the logical extent and current record values are automatically set. Thus, the file can be sequentially read or written, starting from the current randomly accessed position. Note, however, that in this case, the last randomly read record will be re-read as you switch from random mode to sequential read, and the last record will be re-written as you switch to a sequential write operation. You can, of course, simply advance the random record position following each random read or write to obtain the effect of a sequential I/O operation.

Error codes returned in register A following a random read are listed below.

- 01 reading unwritten data
- 02 (not returned in random mode)
- 03 cannot close current extent
- 04 seek to unwritten extent
- 05 (not returned in read mode)
- 06 seek past physical end of disk

Error code 01 and 04 occur when a random read operation accesses a data block which has not been previously written, or an extent which has not been created, which are equivalent conditions. Error 3 does not normally occur under proper system operation, but can be cleared by simply re-reading, or re-opening extent zero as long as the disk is not physically write protected. Error code 06 occurs whenever byte r2 is non-zero under the current 2.0 release. Normally, non-zero return codes can be treated as missing data, with zero return codes indicating operation complete.

#### Function 34: Write Random.

The Write Random operation is initiated similar to the Read Random call, except that data is written to the disk from the current DMA address. Further, if the disk extent or data block which is the target of the write has not yet been allocated, the allocation is performed before the write operation continues. As in the Read Random operation, the random record number is not changed as a result of the write. The logical extent number and current record positions of the file control block are set to correspond to the random record which is being written. Again, sequential read or write operations can commence following a random write, with the notation that the currently addressed record is either read or rewritten again as the sequential operation begins. You can also simply advance the random record position following each write to get the effect of a sequential write operation. Note that in particular, reading or writing the last record of an extent in random mode does not cause an automatic extent

(All Information Contained Herein is Proprietary to Digital Research.)

switch as it does in sequential mode under either CP/M 1.4 or CP/M 2.0.

The error codes returned by a random write are identical to the random read operation with the addition of error code 05, which indicates that a new extent cannot be created due to directory overflow.

#### Function 35: Compute File Size.

When computing the size of a file, the DE register pair addresses an FCB in random mode format (bytes r0, r1, and r2 are present). The FCB contains an unambiguous file name which is used in the directory scan. Upon return, the random record bytes contain the "virtual" file size which is, in effect, the record address of the record following the end of the file. If, following a call to function 35, the high record byte r2 is 01, then the file contains the maximum record count 65536 in version 2.0. Otherwise, bytes r0 and r1 constitute a 16-bit value (r0 is the least significant byte, as before) which is the file size.

Data can be appended to the end of an existing file by simply calling function 35 to set the random record position to the end of file, then performing a sequence of random writes starting at the preset record address.

The virtual size of a file corresponds to the physical size when the file is written sequentially. If, instead, the file was created in random mode and "holes" exist in the allocation, then the file may in fact contain fewer records than the size indicates. If, for example, only the last record of an eight megabyte file is written in random mode (i.e., record number 65535), then the virtual size is 65536 records, although only one block of data is actually allocated.

#### Function 36: Set Random Record.

The Set Random Record function causes the BDOS to automatically produce the random record position from a file which has been read or written sequentially to a particular point. The function can be useful in two ways.

First, it is often necessary to initially read and scan a sequential file to extract the positions of various "key" fields. As each key is encountered, function 36 is called to compute the random record position for the data corresponding to this key. If the data unit size is 128 bytes, the resulting record position is placed into a table with the key for later retrieval. After scanning the entire file and tabularizing the keys and their record numbers, you can move instantly to a particular keyed record by performing a random read using the corresponding random record number which was saved earlier. The scheme is easily generalized when variable record lengths are

(All Information Contained Herein is Proprietary to Digital Research.)

involved since the program need only store the buffer-relative byte position along with the key and record number in order to find the exact starting position of the keyed data at a later time.

A second use of function 36 occurs when switching from a sequential read or write over to random read or write. A file is sequentially accessed to a particular point in the file, function 36 is called which sets the record number, and subsequent random read and write operations continue from the selected point in the file.

This section is concluded with a rather extensive, but complete example of random access operation. The program listed below performs the simple function of reading or writing random records upon command from the terminal. Given that the program has been created, assembled, and placed into a file labelled RANDOM.COM, the CCP level command:

#### RANDOM X.DAT

starts the test program. The program looks for a file by the name X.DAT (in this particular case) and, if found, proceeds to prompt the console for input. If not found, the file is created before the prompt is given. Each prompt takes the form

next command?

and is followed by operator input, terminated by a carriage return. The input commands take the form

nW nR Q

where n is an integer value in the range 0 to 65535, and W, R, and Q are simple command characters corresponding to random write, random read, and quit processing, respectively. If the W command is issued, the RANDOM program issues the prompt

type data:

The operator then responds by typing up to 127 characters, followed by a carriage return. RANDOM then writes the character string into the X.DAT file at record n. If the R command is issued, RANDOM reads record number n and displays the string value at the console. If the Q command is issued, the X.DAT file is closed, and the program returns to the console command processor. In the interest of brevity (ok, so the program's not so brief), the only error message is

error, try again

The program begins with an initialization section where the input file is opened or created, followed by a continuous loop at the label "ready" where the individual commands are interpreted. The default file control block at 005CH and the default buffer at 0080H are used in all disk operations. The utility subroutines then follow,

(All Information Contained Herein is Proprietary to Digital Research.)

which contain the principal input line processor, called "readc." This particular program shows the elements of random access processing, and can be used as the basis for further program development.

```

;*****
;*
;* sample random access program for cp/m 2.0
;*
;*****
0100      org      100h      ;base of tpa
;
0000 =    reboot   equ      0000h  ;system reboot
0005 =    bdos     equ      0005h  ;bdos entry point
;
0001 =    coninp   equ      1       ;console input function
0002 =    conout   equ      2       ;console output function
0009 =    pstring  equ      9       ;print string until '$'
000a =    rstring  equ      10      ;read console buffer
000c =    version  equ      12      ;return version number
000f =    openf    equ      15      ;file open function
0010 =    closef   equ      16      ;close function
0016 =    makef    equ      22      ;make file function
0021 =    readr    equ      33      ;read random
0022 =    writer   equ      34      ;write random
;
005c =    fcb      equ      005ch   ;default file control block
007d =    ranrec   equ      fcb+33   ;random record position
007f =    ranovf   equ      fcb+35   ;high order (overflow) byte
0080 =    buff     equ      0080h   ;buffer address
;
000d =    cr       equ      0dh     ;carriage return
000a =    lf       equ      0ah     ;line feed
;
;*****
;*
;* load SP, set-up file for random access
;*
;*****
0100 31bc0      lxi      sp,stack
;
;          version 2.0?
0103 0e0c      mvi      c,version
0105 cd050     call     bdos
0108 fe20      cpi      20h      ;version 2.0 or better?
010a d2160     jnc      versok
;          bad version, message and go back
010d 111b0     lxi      d,badver
0110 cdda0     call     print
0113 c3000     jmp     reboot
;
versok:
;          correct version for random access

```

(All Information Contained Herein is Proprietary to Digital Research.)

```

0116 0e0f      mvi      c,openf ;open default fcb
0118 115c0     lxi      d,fcf
011b cd050     call     bdos
011e 3c        inr      a        ;err 255 becomes zero
011f c2370     jnz      ready

;
;      cannot open file, so create it
0122 0e16      mvi      c,makef
0124 115c0     lxi      d,fcf
0127 cd050     call     bdos
012a 3c        inr      a        ;err 255 becomes zero
012b c2370     jnz      ready

;
;      cannot create file, directory full
012e 113a0     lxi      d,nospace
0131 cdda0     call     print
0134 c3000     jmp      reboot ;back to ccp

;
;*****
;*
;* loop back to "ready" after each command
;*
;*****
;
ready:
;      file is ready for processing
;
0137 cde50     call     readcom ;read next command
013a 227d0     shld    ranrec ;store input record#
013d 217f0     lxi      h,ranovf
0140 3600      mvi      m,0      ;clear high byte if set
0142 fe51     cpi      'Q'      ;quit?
0144 c2560     jnz      notq

;
;      quit processing, close file
0147 0e10      mvi      c,closef
0149 115c0     lxi      d,fcf
014c cd050     call     bdos
014f 3c        inr      a        ;err 255 becomes 0
0150 cab90     jz       error   ;error message, retry
0153 c3000     jmp      reboot ;back to ccp

;
;*****
;*
;* end of quit command, process write
;*
;*****
notq:
;      not the quit command, random write?
0156 fe57     cpi      'W'
0158 c2890     jnz      notw

;
;      this is a random write, fill buffer until cr
015b 114d0     lxi      d,datmsg
015e cdda0     call     print ;data prompt

```

(All Information Contained Herein is Proprietary to Digital Research.)

```

0161 0e7f      mvi      c,127    ;up to 127 characters
0163 21800    lxi      h,buff   ;destination
                    rloop: ;read next character to buff
0166 c5        push     b         ;save counter
0167 e5        push     h         ;next destination
0168 cdc20    call    getchr    ;character to a
016b e1        pop      h         ;restore counter
016c c1        pop      b         ;restore next to fill
016d fe0d     cpi      cr        ;end of line?
016f ca780    jz       erloop
                    ;
                    ; not end, store character
0172 77        mov      m,a
0173 23        inx     h         ;next to fill
0174 0d        dcr     c         ;counter goes down
0175 c2660    jnz     rloop    ;end of buffer?
                    erloop:
                    ;
                    ; end of read loop, store 00
0178 3600     mvi     m,0
                    ;
                    ;
                    ; write the record to selected record number
017a 0e22     mvi     c,writer
017c 115c0    lxi     d,fcbl
017f cd050    call   bdos
0182 b7        ora     a         ;error code zero?
0183 c2b90    jnz    error    ;message if not
0186 c3370    jmp    ready    ;for another record
                    ;
                    ;*****
                    ;*
                    ;* end of write command, process read
                    ;*
                    ;*****
                    notw:
                    ;
                    ; not a write command, read record?
0189 fe52     cpi     'R'
018b c2b90    jnz    error    ;skip if not
                    ;
                    ;
                    ; read random record
018e 0e21     mvi     c,readr
0190 115c0    lxi     d,fcbl
0193 cd050    call   bdos
0196 b7        ora     a         ;return code 00?
0197 c2b90    jnz    error
                    ;
                    ;
                    ; read was successful, write to console
019a cdcf0     call   crlf      ;new line
019d 0e80     mvi     c,128    ;max 128 characters
019f 21800    lxi     h,buff   ;next to get
                    wloop:
01a2 7e        mov     a,m      ;next character
01a3 23        inx     h         ;next to get
01a4 e67f     ani     7fh      ;mask parity
01a6 ca370    jz     ready    ;for another command if 00
01a9 c5        push    b         ;save counter
01aa e5        push    h         ;save next to get

```

(All Information Contained Herein is Proprietary to Digital Research.)

```

01ab fe20      cpi          ;graphic?
01ad d4c80     cnc          putchar ;skip output if not
01b0 e1        pop          h
01b1 c1        pop          b
01b2 0d        dcr          c          ;count=count-1
01b3 c2a20     jnz          wloop
01b6 c3370     jmp          ready
;
;*****
;*
;* end of read command, all errors end-up here
;*
;*****
;
error:
01b9 11590     lxi          d,errmsg
01bc cd0a0     call         print
01bf c3370     jmp          ready
;
;*****
;*
;* utility subroutines for console i/o
;*
;*****
getchr:
;read next console character to a
01c2 0e01     mvi          c,coninp
01c4 cd050     call         bdos
01c7 c9        ret
;
putchr:
;write character from a to console
01c8 0e02     mvi          c,conout
01ca 5f        mov          e,a          ;character to send
01cb cd050     call         bdos        ;send character
01ce c9        ret
;
crlf:
;send carriage return line feed
01cf 3e0d     mvi          a,cr        ;carriage return
01d1 cdc80     call         putchar
01d4 3e0a     mvi          a,lf        ;line feed
01d6 cdc80     call         putchar
01d9 c9        ret
;
print:
;print the buffer addressed by de until $
01da d5        push         d
01db cdcf0     call         crlf
01de dl        pop          d          ;new line
01df 0e09     mvi          c,pstring
01e1 cd050     call         bdos        ;print the string
01e4 c9        ret
;
readcom:

```

(All Information Contained Herein is Proprietary to Digital Research.)



```

;read the next command line to the conbuf
01e5 116b0 lxi d,prompt
01e8 cdda0 call print ;command?
01eb 0e0a mvi c,rstring
01ed 117a0 lxi d,conbuf
01f0 cd050 call bdos ;read command line
; command line is present, scan it
01f3 21000 lxi h,0 ;start with 0000
01f6 117c0 lxi d,conlin;command line
01f9 la readc: ldax d ;next command character
01fa 13 inx d ;to next command position
01fb b7 ora a ;cannot be end of command
01fc c8 rz
; not zero, numeric?
01fd d630 sui '0'
01ff fe0a cpi l0 ;carry if numeric
0201 d2130 jnc endrd
; add-in next digit
0204 29 dad h ;*2
0205 4d mov c,l
0206 44 mov b,h ;bc = value * 2
0207 29 dad h ;*4
0208 29 dad h ;*8
0209 09 dad b ;*2 + *8 = *10
020a 85 add l ;+digit
020o 6r mov l,a
020c d2f90 jnc readc ;for another char
020f 24 inr h ;overflow
0210 c3f90 jmp readc ;for another char
endrd:
; end of read, restore value in a
0213 c630 adi '0' ;command
0215 fe61 cpi 'a' ;translate case?
0217 d8 rc
; lower case, mask lower case bits
0218 e65f ani l0l$1111b
021a c9 ret
;
;*****
;*
;* string data area for console messages
;*
;*****
badver:
021b 536f79 db 'sorry, you need cp/m version 2$'
nospace:
023a 4e6f29 db 'no directory space$'
datmsg:
024d 547970 db 'type data: $'
errmsg:
0259 457272 db 'error, try again.$'
prompt:
026b 4e6570 db 'next command? $'
;

```

(All Information Contained Herein is Proprietary to Digital Research.)

```

;*****
;*
;* fixed and variable data area
;*
;*****
027a 21  conbuf: db      conlen  ;length of console buffer
027b      consiz: ds      1      ;resulting size after read
027c      conlin: ds     32      ;length 32 buffer
0021 =   conlen  equ     $-consiz
;
029c      ds      32      ;16 level stack
stack:
02bc      end

```

## 9. CP/M 2.0 MEMORY ORGANIZATION.

Similar to earlier versions, CP/M 2.0 is field-altered to fit various memory sizes, depending upon the host computer memory configuration. Typical base addresses for popular memory sizes are shown in the table below.

Module	20k	24k	32k	48k	64k
CCP	3400H	4400H	6400H	A400H	E400H
BDOS	3C00H	4C00H	6C00H	AC00H	EC00H
BIOS	4A00H	5A00H	7A00H	BA00H	FA00H
Top of Ram	4FFFH	5FFFH	7FFFH	BFFFH	FFFFH

The distribution disk contains a CP/M 2.0 system configured for a 20k Intel MDS-800 with standard IBM 8" floppy disk drives. The disk layout is shown below:

Sector	Track 00	Module	Track 01	Module
1	(Bootstrap Loader)		4080H	BDOS + 480H
2	3400H	CCP + 000H	4100H	BDOS + 500H
3	3480H	CCP + 080H	4180H	BDOS + 580H
4	3500H	CCP + 100H	4200H	BDOS + 600H
5	3580H	CCP + 180H	4280H	BDOS + 680H
6	3600H	CCP + 200H	4300H	BDOS + 700H
7	3680H	CCP + 280H	4380H	BDOS + 780H
8	3700H	CCP + 300H	4400H	BDOS + 800H
9	3780H	CCP + 380H	4480H	BDOS + 880H
10	3800H	CCP + 400H	4500H	BDOS + 900H
11	3880H	CCP + 480H	4580H	BDOS + 980H
12	3900H	CCP + 500H	4600H	BDOS + A00H
13	3980H	CCP + 580H	4680H	BDOS + A80H
14	3A00H	CCP + 600H	4700H	BDOS + B00H
15	3A80H	CCP + 680H	4780H	BDOS + B80H
16	3B00H	CCP + 700H	4800H	BDOS + C00H
17	3B80H	CCP + 780H	4880H	BDOS + C80H
18	3C00H	BDOS + 000H	4900H	BDOS + D00H
19	3C80H	BDOS + 080H	4980H	BDOS + D80H
20	3D00H	BDOS + 100H	4A00H	BIOS + 000H
21	3D80H	BDOS + 180H	4A80H	BIOS + 080H
22	3E00H	BDOS + 200H	4B00H	BIOS + 100H
23	3E80H	BDOS + 280H	4B80H	BIOS + 180H
24	3F00H	BDOS + 300H	4C00H	BIOS + 200H
25	3F80H	BDOS + 380H	4C80H	BIOS + 280H
26	4000H	BDOS + 400H	4D00H	BIOS + 300H

In particular, note that the CCP is at the same position on the disk, and occupies the same space as version 1.4. The BDOS portion, however, occupies one more 256-byte page and the BIOS portion extends through the remainder of track 01. Thus, the CCP is 800H (2048 decimal) bytes in length, the BDOS is E00H (3584 decimal) bytes in length, and the BIOS is up to 380H (898 decimal) bytes in length. In version 2.0, the BIOS portion contains the standard subroutines of 1.4, along with some initialized table space, as described in the following section.

(All Information Contained Herein is Proprietary to Digital Research.)

## 10. BIOS DIFFERENCES.

The CP/M 2.0 Basic I/O System differs only slightly in concept from its predecessors. Two new jump vector entry points are defined, a new sector translation subroutine is included, and a disk characteristics table must be defined. The skeletal form of these changes are found in the program shown below.

```
1:      org      4000h
2:      maclib  diskdef
3:      jmp      boot
4: ;
5:      jmp      listst ;list status
6:      jmp      sectran ;sector translate
7:      disks   4
8: ;
9:      bpb     equ      16*1024 ;bytes per block
10:     rpb     equ      bpb/128 ;records per block
11:     maxb    equ      65535/rpb ;max block number
12:     diskdef 0,1,58,3,bpb,maxb+1,128,0,2
13:     diskdef 1,1,58,,bpb,maxb+1,128,0,2
14:     diskdef 2,0
15:     diskdef 3,1
16: ;
17: boot:  ret      ;nop
18: ;
19: listst: xra     a      ;nop
20:         ret
21: ;
22: seldsk:
23:         ;drive number in c
24:         lxi     h,0      ;0000 in hl produces select error
25:         mov     a,c      ;a is disk number 0 ... ndisks-1
26:         cpi     ndisks   ;less than ndisks?
27:         rnc
28:         ;return with HL = 0000 if not
29:         ;proper disk number, return dpb element address
30:         mov     l,c
31:         dad     h        ;*2
32:         dad     h        ;*4
33:         dad     h        ;*8
34:         dad     h        ;*16
35:         lxi     d,dpbase
36:         dad     d        ;HL=.dpb
37:         ret
38: ;
39: selsec:
40:         ;sector number in c
41:         lxi     h,sector
42:         mov     m,c
43:         ret
44: ;
45: sectran:
46:         ;translate sector BC using table at DE
47:         xchg
48:         ;HL = .tran
49:         dad     b        ;single precision tran
```

(All Information Contained Herein is Proprietary to Digital Research.)

```

48: ;      dad b again if double precision tran
49:      mov    l,m      ;only low byte necessary here
50: ;      fill both H and L if double precision tran
51:      ret          ;HL = ??ss
52: ;
53: sector: ds      1
54:      endef
55:      end

```

Referring to the program shown above, lines 3-6 represent the BIOS entry vector of 17 elements (version 1.4 defines only 15 jump vector elements). The last two elements provide access to the "LISTST" (List Status) entry point for DESPOOL. The use of this particular entry point is defined in the DESPOOL documentation, and is no different than the previous 1.4 release. It should be noted that the 1.4 DESPOOL program will not operate under version 2.0, but an update version will be available from Digital Research in the near future.

The "SECTTRAN" (Sector Number Translate) entry shown in the jump vector at line 6 provides access to a BIOS-resident sector translation subroutine. This mechanism allows the user to specify the sector skew factor and translation for a particular disk system, and is described below.

A macro library is shown in the listing, called DISKDEF, included on line 2, and referenced in 12-15. Although it is not necessary to use the macro library, it greatly simplifies the disk definition process. You must have access to the MAC macro assembler, of course, to use the DISKDEF facility, while the macro library is included with all CP/M 2.0 distribution disks. (See the CP/M 2.0 Alteration Guide for formulas which you can use to hand-code the tables produced by the DISKDEF library).

A BIOS disk definition consists of the following sequence of macro statements:

```

MACLIB  DISKDEF
.....
DISKS   n
DISKDEF 0,...
DISKDEF 1,...
.....
DISKDEF n-1
.....
ENDEF

```

where the MACLIB statement loads the DISKDEF.LIB file (on the same disk as your BIOS) into MAC's internal tables. The DISKS macro call follows, which specifies the number of drives to be configured with your system, where n is an integer in the range 1 to 16. A series of DISKDEF macro calls then follow which define the characteristics of each logical disk, 0 through n-1 (corresponding to logical drives A through P). Note that the DISKS and DISKDEF macros generate in-line

(All Information Contained Herein is Proprietary to Digital Research.)

fixed data tables, and thus must be placed in a non-executable portion of your BIOS, typically directly following the BIOS jump vector.

The remaining portion of your BIOS is defined following the DISKDEF macros, with the ENDEF macro call immediately preceding the END statement. The ENDEF (End of Diskdef) macro generates the necessary uninitialized RAM areas which are located above your BIOS.

The form of the DISKDEF macro call is

```
DISKDEF dn,fsc,lsc,[skf],bls,dks,dir,cks,ofs,[0]
```

where

dn	is the logical disk number, 0 to n-1
fsc	is the first physical sector number (0 or 1)
lsc	is the last sector number
skf	is the optional sector skew factor
bls	is the data allocation block size
dir	is the number of directory entries
cks	is the number of "checked" directory entries
ofs	is the track offset to logical track 00
[0]	is an optional 1.4 compatibility flag

The value "dn" is the drive number being defined with this DISKDEF macro invocation. The "fsc" parameter accounts for differing sector numbering systems, and is usually 0 or 1. The "lsc" is the last numbered sector on a track. When present, the "skf" parameter defines the sector skew factor which is used to create a sector translation table according to the skew. If the number of sectors is less than 256, a single-byte table is created, otherwise each translation table element occupies two bytes. No translation table is created if the skf parameter is omitted (or equal to 0). The "bls" parameter specifies the number of bytes allocated to each data block, and takes on the values 1024, 2048, 4096, 8192, or 16384. Generally, performance increases with larger data block sizes since there are fewer directory references and logically connected data records are physically close on the disk. Further, each directory entry addresses more data and the BIOS-resident ram space is reduced. The "dks" specifies the total disk size in "bls" units. That is, if the bls = 2048 and dks = 1000, then the total disk capacity is 2,048,000 bytes. If dks is greater than 255, then the block size parameter bls must be greater than 1024. The value of "dir" is the total number of directory entries which may exceed 255, if desired. The "cks" parameter determines the number of directory items to check on each directory scan, and is used internally to detect changed disks during system operation, where an intervening cold or warm start has not occurred (when this situation is detected, CP/M automatically marks the disk read/only so that data is not subsequently destroyed). Normally the value of cks = dir when the media is easily changed, as is the case with a floppy disk subsystem. If the disk is permanently mounted, then the value of cks is typically 0, since the probability of changing disks without a restart is quite low. The "ofs" value determines the number of tracks to skip when this particular drive is addressed, which can be used to reserve additional operating system

(All Information Contained Herein is Proprietary to Digital Research.)

space or to simulate several logical drives on a single large capacity physical drive. Finally, the [0] parameter is included when file compatibility is required with versions of 1.4 which have been modified for higher density disks. This parameter ensures that only 16K is allocated for each directory record, as was the case for previous versions. Normally, this parameter is not included.

For convenience and economy of table space, the special form

```
DISKDEF i,j
```

gives disk i the same characteristics as a previously defined drive j. A standard four-drive single density system, which is compatible with version 1.4, is defined using the following macro invocations:

```
DISKS      4
DISKDEF    0,1,26,6,1024,243,64,64,2
DISKDEF    1,0
DISKDEF    2,0
DISKDEF    3,0
```

```
....
ENDEF
```

with all disks having the same parameter values of 26 sectors per track (numbered 1 through 26), with 6 sectors skipped between each access, 1024 bytes per data block, 243 data blocks for a total of 243k byte disk capacity, 64 checked directory entries, and two operating system tracks.

The definitions given in the program shown above (lines 12 through 15) provide access to the largest disks addressable by CP/M 2.0. All disks have identical parameters, except that drives 0 and 2 skip three sectors on every data access, while disks 1 and 3 access each sector in sequence as the disk revolves (there may, however, be a transparent hardware skew factor on these drives).

The DISKS macro generates n "disk header blocks," starting at address DPBASE which is a label generated by the macro. Each disk header block contains sixteen bytes, and correspond, in sequence, to each of the defined drives. In the four drive standard system, for example, the DISKS macro generates a table of the form:

```
DPBASE EQU $
DPE0:  DW  XLT0,0000H,0000H,0000H,DIRBUF,DPB0,CSV0,ALV0
DPE1:  DW  XLT0,0000H,0000H,0000H,DIRBUF,DPB0,CSV1,ALV1
DPE2:  DW  XLT0,0000H,0000H,0000H,DIRBUF,DPB0,CSV2,ALV2
DPE3:  DW  XLT0,0000H,0000H,0000H,DIRBUF,DPB0,CSV3,ALV3
```

where the DPE (disk parameter entry) labels are included for reference purposes to show the beginning table addresses for each drive 0 through 3. The values contained within the disk parameter header are described in detail in the CP/M 2.0 Alteration Guide, but basically address the translation vector for the drive (all reference XLT0, which is the translation vector for drive 0 in the above example),

(All Information Contained Herein is Proprietary to Digital Research.)

followed by three 16-bit "scratch" addresses, followed by the directory buffer address, disk parameter block address, check vector address, and allocation vector address. The check and allocation vector addresses are generated by the ENDEF macro in the ram area following the BIOS code and tables.

The SELDSK function is extended somewhat in version 2.0. In particular, the selected disk number is passed to the BIOS in register C, as before, and the SELDSK subroutine performs the appropriate software or hardware actions to select the disk. Version 2.0, however, also requires the SELDSK subroutine to return the address of the selected disk parameter header (DPE0, DPE1, DPE2, or DPE3, in the above example) in register HL. If SELDSK returns the value HL = 0000H, then the BDOS assumes the disk does not exist, and prints a select error message at the terminal. Program lines 22 through 36 give a sample CP/M 2.0 SELDSK subroutine, showing only the disk parameter header address calculation.

The subroutine SECTRAN is also included in version 2.0 which performs the actual logical to physical sector translation. In earlier versions of CP/M, the sector translation process was a part of the BDOS, and set to skip six sectors between each read. Due to differing rotational speeds of various disks, the translation function has become a part of the BIOS in version 2.0. Thus, the BDOS sends sequential sector numbers to SECTRAN, starting at sector number 0. The SECTRAN subroutine uses the sequential sector number to produce a translated sector number which is returned to the BDOS. The BDOS subsequently sends the translated sector number to SELSEC before the actual read or write is performed. Note that many controllers have the capability to record the sector skew on the disk itself, and thus there is no translation necessary. In this case, the "skf" parameter is omitted in the macro call, and SECTRAN simply returns the same value which it receives. The table shown below, for example, is constructed when the standard skew factor skf = 6 is specified in the DISKDEF macro call:

```
XLT0:  DB    1,7,13,19,25,5,11,17,23,3,9,15,21
        DB    2,8,14,20,26,6,12,18,24,4,10,16,22
```

If SECTRAN is required to translate a sector, then the following process takes place. The sector to translate is received in register pair BC. Only the C register is significant if the sector value does not exceed 255 (B = 00 in this case). Register pair DE addresses the sector translate table for this drive, determined by a previous call on SELDSK, corresponding to the first element of a disk parameter header (XLT0 in the case shown above). The SECTRAN subroutine then fetches the translated sector number by adding the input sector number to the base of the translate table, to get the indexed translate table address (see lines 46, 47, and 48 in the above program). The value at this location is then returned in register L. Note that if the number of sectors exceeds 255, the translate table contains 16-bit elements whose value must be returned in HL.

Following the ENDEF macro call, a number of uninitialized data areas are defined. These data areas need not be a part of the BIOS

(All Information Contained Herein is Proprietary to Digital Research.)



which is loaded upon cold start, but must be available between the BIOS and the end of memory. The size of the uninitialized RAM area is determined by EQU statements generated by the ENDEF macro. For a standard four-drive system, the ENDEF macro might produce

```
4C72 =      BEGDAT EQU $  
          (data areas)  
4DB0 =      ENDDAT EQU $  
013C =      DATSIZ EQU $-BEGDAT
```

which indicates that uninitialized RAM begins at location 4C72H, ends at 4DB0H-1, and occupies 013CH bytes. You must ensure that these addresses are free for use after the system is loaded.

CP/M 2.0 is also easily adapted to disk subsystems whose sector size is a multiple of 128 bytes. Information is provided by the BDOS on sector write operations which eliminates the need for pre-read operations, thus allowing blocking and deblocking to take place at the BIOS level.

See the "CP/M 2.0 Alteration Guide" for additional details concerning tailoring your CP/M system to your particular hardware.



**AN INTRODUCTION TO CP/M FEATURES AND FACILITIES**

## COPYRIGHT

Copyright (c) 1980 by Exidy Systems, Inc. All rights reserved. No part of this publication may be reproduced, transmitted, transcribed, stored in a retrieval system, or translated into any language, in any form or by any means, electronic, mechanical, magnetic, optical, chemical, manual, or otherwise, without the prior written permission of Exidy Systems, Inc., 1234 Elko Drive, Sunnyvale, California 94086.

Since this manual is tutorial in nature, permission is granted to reproduce or abstract the example procedures and sample programs for the purposes of inclusion within the reader's programs.

## DISCLAIMER

Exidy Systems, Inc. makes no representations or warranties with respect to the contents hereof and specifically disclaims any implied warranties of merchantability or fitness for any particular purpose. Further, Exidy Systems, Inc. reserves the right to revise this publication and to make changes from time to time in the content hereof without obligation of Exidy Systems, Inc. to notify any person of such revision or changes.

## TRADEMARKS

CP/M is a registered trademark of Digital Research.

**AN INTRODUCTION TO CP/M FEATURES AND FACILITIES**

## COPYRIGHT

Copyright (c) 1980 by Exidy Systems, Inc. All rights reserved. No part of this publication may be reproduced, transmitted, transcribed, stored in a retrieval system, or translated into any language, in any form or by any means, electronic, mechanical, magnetic, optical, chemical, manual, or otherwise, without the prior written permission of Exidy Systems, Inc., 1234 Elko Drive, Sunnyvale, California 94086.

Since this manual is tutorial in nature, permission is granted to reproduce or abstract the example procedures and sample programs for the purposes of inclusion within the reader's programs.

## DISCLAIMER

Exidy Systems, Inc. makes no representations or warranties with respect to the contents hereof and specifically disclaims any implied warranties of merchantability or fitness for any particular purpose. Further, Exidy Systems, Inc. reserves the right to revise this publication and to make changes from time to time in the content hereof without obligation of Exidy Systems, Inc. to notify any person of such revision or changes.

## TRADEMARKS

CP/M is a registered trademark of Digital Research.

## Table Of Contents

### An Introduction To CP/M Features and Facilities

1.	Introduction.....	35
2.	Functional Description Of CP/M.....	37
	2.1 General Command Structure.....	37
	2.2 File References.....	37
3.	Switching Disks.....	40
4.	The Form Of Built-In Commands.....	41
	4.1 ERA afn cr.....	41
	4.2 DIR afn cr.....	42
	4.3 REN ufn1=ufn2 cr.....	42
	4.4 SAVE n ufn cr.....	43
	4.5 TYPE ufn cr.....	43
5.	Line Editing And Output Control.....	45
6.	Transient Commands.....	46
	6.1 STAT cr.....	47
	6.2 ASM ufn cr.....	50
	6.3 LOAD ufn cr.....	51
	6.4 PIP cr.....	52
	6.5 ED ufn cr.....	59
	6.6 SYSGEN cr.....	61
	6.7 SUBMIT ufn parm#1 parm#n cr.....	62
	6.8 DUMP ufn cr.....	64
	6.9 MOVCPM cr.....	64
7.	BDOS Error Messages.....	67
8.	Operation Of CP/M On The MDS.....	69





## 1. INTRODUCTION.

CP/M is a monitor control program for microcomputer system development which uses IBM-compatible flexible disks for backup storage. Using a computer mainframe based upon Intel's 8080 microcomputer, CP/M provides a general environment for program construction, storage, and editing, along with assembly and program check-out facilities. An important feature of CP/M is that it can be easily altered to execute with any computer configuration which uses an Intel 8080 (or Zilog Z-80) Central Processing Unit, and has at least 16K bytes of main memory with up to four IBM-compatible diskette drives. A detailed discussion of the modifications required for any particular hardware environment is given in the Digital Research document entitled "CP/M System Alteration Guide." Although the standard Digital Research version operates on a single-density Intel MDS 800, several different hardware manufacturers support their own input-output drivers for CP/M.

The CP/M monitor provides rapid access to programs through a comprehensive file management package. The file subsystem supports a named file structure, allowing dynamic allocation of file space as well as sequential and random file access. Using this file system, a large number of distinct programs can be stored in both source and machine executable form.

CP/M also supports a powerful context editor, Intel-compatible assembler, and debugger subsystems. Optional software includes a powerful Intel-compatible macro assembler, symbolic debugger, along with various high-level languages. When coupled with CP/M's Console Command Processor, the resulting facilities equal or excel similar large computer facilities.

CP/M is logically divided into several distinct parts:

BIOS	Basic I/O System (hardware dependent)
BDOS	Basic Disk Operating System
CCP	Console Command Processor
TPA	Transient Program Area

The BIOS provides the primitive operations necessary to access the diskette drives and to interface standard peripherals (teletype, CRT, Paper Tape Reader/Punch, and user-defined peripherals), and can be tailored by the user for any particular hardware environment by "patching" this portion of CP/M. The BDOS provides disk management by controlling one or more disk drives containing independent file directories. The BDOS implements disk allocation strategies which provide fully dynamic file construction while minimizing head movement across the disk during access. Any particular file may contain any number of records, not exceeding the size of any single disk. In a standard CP/M system, each disk can contain up to 64 distinct files. The

BDOS has entry points which include the following primitive operations which can be programmatically accessed:

SEARCH	Look for a particular disk file by name.
OPEN	Open a file for further operations.
CLOSE	Close a file after processing.
RENAME	Change the name of a particular file.
READ	Read a record from a particular file.
WRITE	Write a record onto the disk.
SELECT	Select a particular disk drive for further operations.

The CCP provides symbolic interface between the user's console and the remainder of the CP/M system. The CCP reads the console device and processes commands which include listing the file directory, printing the contents of files, and controlling the operation of transient programs, such as assemblers, editors, and debuggers. The standard commands which are available in the CCP are listed in a following section.

The last segment of CP/M is the area called the Transient Program Area (TPA). The TPA holds programs which are loaded from the disk under command of the CCP. During program editing, for example, the TPA holds the CP/M text editor machine code and data areas. Similarly, programs created under CP/M can be checked out by loading and executing these programs in the TPA.

It should be mentioned that any or all of the CP/M component subsystems can be "overlayed" by an executing program. That is, once a user's program is loaded into the TPA, the CCP, BDOS, and BIOS areas can be used as the program's data area. A "bootstrap" loader is programmatically accessible whenever the BIOS portion is not overlayed; thus, the user program need only branch to the bootstrap loader at the end of execution, and the complete CP/M monitor is reloaded from disk.

It should be reiterated that the CP/M operating system is partitioned into distinct modules, including the BIOS portion which defines the hardware environment in which CP/M is executing. Thus, the standard system can be easily modified to any non-standard environment by changing the peripheral drivers to handle the custom system.

## 2. FUNCTIONAL DESCRIPTION OF CP/M.

The user interacts with CP/M primarily through the CCP, which reads and interprets commands entered through the console. In general, the CCP addresses one of several disks which are online (the standard system addresses up to four different disk drives). These disk drives are labelled A, B, C, and D. A disk is "logged in" if the CCP is currently addressing the disk. In order to clearly indicate which disk is the currently logged disk, the CCP always prompts the operator with the disk name followed by the symbol ">" indicating that the CCP is ready for another command. Upon initial start up, the CP/M system is brought in from disk A, and the CCP displays the message

```
xxK CP/M VER m.m
```

where xx is the memory size (in kilobytes) which this CP/M system manages, and m.m is the CP/M version number. All CP/M systems are initially set to operate in a 16K memory space, but can be easily reconfigured to fit any memory size on the host system (see the MOVCPM transient command). Following system signon, CP/M automatically logs in disk A, prompts the user with the symbol "A>" (indicating that CP/M is currently addressing disk "A"), and waits for a command. The commands are implemented at two levels: built-in commands and transient commands.

### 2.1. GENERAL COMMAND STRUCTURE.

Built-in commands are a part of the CCP program itself, while transient commands are loaded into the TPA from disk and executed. The built-in commands are

ERA	Erase specified files.
DIR	List file names in the directory.
REN	Rename the specified file.
SAVE	Save memory contents in a file.
TYPE	Type the contents of a file on the logged disk.

Nearly all of the commands reference a particular file or group of files. The form of a file reference is specified below.

### 2.2. FILE REFERENCES.

A file reference identifies a particular file or group of files on a particular disk attached to CP/M. These file references can be either "unambiguous" (ufn) or "ambiguous" (afn). An unambiguous file reference uniquely identifies a single file, while an ambiguous file reference may be

satisfied by a number of different files.

File references consist of two parts: the primary name and the secondary name. Although the secondary name is optional, it usually is generic; that is, the secondary name "ASM," for example, is used to denote that the file is an assembly language source file, while the primary name distinguishes each particular source file. The two names are separated by a "." as shown below:

pppppppp.sss

where pppppppp represents the primary name of eight characters or less, and sss is the secondary name of no more than three characters. As mentioned above, the name

pppppppp

is also allowed and is equivalent to a secondary name consisting of three blanks. The characters used in specifying an unambiguous file reference cannot contain any of the special characters

< > . , ; : = ? \* [ ]

while all alphanumerics and remaining special characters are allowed.

An ambiguous file reference is used for directory search and pattern matching. The form of an ambiguous file reference is similar to an unambiguous reference, except the symbol "?" may be interspersed throughout the primary and secondary names. In various commands throughout CP/M, the "?" symbol matches any character of a file name in the "?" position. Thus, the ambiguous reference

X?Z.C?M

is satisfied by the unambiguous file names

XYZ.COM

and

X3Z.CAM

Note that the ambiguous reference

\*.\*

is equivalent to the ambiguous file reference

?????????.???

while

and PPPPPPPP.\*  
\*.SSS

are abbreviations for

and PPPPPPPP.???  
?????????.SSS

respectively. As an example,

DIR \*.\*

is interpreted by the CCP as a command to list the names of all disk files in the directory, while

DIR X.Y

searches only for a file by the name X.Y Similarly, the command

DIR X?Y.C?M

causes a search for all (unambiguous) file names on the disk which satisfy this ambiguous reference.

The following file names are valid unambiguous file references:

X	XYZ	GAMMA
X.Y	XYZ.COM	GAMMA.1

As an added convenience, the programmer can generally specify the disk drive name along with the file name. In this case, the drive name is given as a letter A through Z followed by a colon (:). The specified drive is then "logged in" before the file operation occurs. Thus, the following are valid file names with disk name prefixes:

A:X.Y	B:XYZ	C:GAMMA
Z:XYZ.COM	B:X.A?M	C:*.ASM

It should also be noted that all alphabetic lower case letters in file and drive names are always translated to upper case when they are processed by the CCP.

### 3. SWITCHING DISKS.

The operator can switch the currently logged disk by typing the disk drive name (A, B, C, or D) followed by a colon (:) when the CCP is waiting for console input. Thus, the sequence of prompts and commands shown below might occur after the CP/M system is loaded from disk A:

16K CP/M VER 1.4

A>DIR                   List all files on disk A.

SAMPLE   ASM

SAMPLE   PRN

A>B:                    Switch to disk B.

B>DIR \*.ASM            List all "ASM" files on B.

DUMP     ASM

FILES    ASM

B>A:                    Switch back to A.

#### 4. THE FORM OF BUILT-IN COMMANDS.

The file and device reference forms described above can now be used to fully specify the structure of the built-in commands. In the description below, assume the following abbreviations:

ufn - unambiguous file reference  
afn - ambiguous file reference  
cr - carriage return

Further, recall that the CCP always translates lower case characters to upper case characters internally. Thus, lower case alphabetic characters are treated as if they are upper case in command names and file references.

##### 4.1 ERA afn cr

The ERA (erase) command removes files from the currently logged-in disk (i.e., the disk name currently prompted by CP/M preceding the ">"). The files which are erased are those which satisfy the ambiguous file reference afn. The following examples illustrate the use of ERA:

ERA X.Y	The file named X.Y on the currently logged disk is removed from the disk directory, and the space is returned.
ERA X.*	All files with primary name X are removed from the current disk.
ERA *.ASM	All files with secondary name ASM are removed from the current disk.
ERA X?Y.C?M	All files on the current disk which satisfy the ambiguous reference X?Y.C?M are deleted.
ERA *.*	Erase all files on the current disk (in this case the CCP prompts the console with the message "ALL FILES (Y/N)?" which requires a Y response before files are actually removed).
ERA B:*.PRN	All files on drive B which satisfy the ambiguous reference ???????.PRN are deleted, independently of the currently logged disk.

## 4.2. DIR afn cr

The DIR (directory) command causes the names of all files which satisfy the ambiguous file name afn to be listed at the console device. As a special case, the command

```
DIR
```

lists the files on the currently logged disk (the command "DIR" is equivalent to the command "DIR \*.\*"). Valid DIR commands are shown below.

```
DIR X.Y
```

```
DIR X?Z.C?M
```

```
DIR ??.Y
```

Similar to other CCP commands, the afn can be preceded by a drive name. The following DIR commands cause the selected drive to be addressed before the directory search takes place.

```
DIR B:
```

```
DIR B:X.Y
```

```
DIR B:*.A?M
```

If no files can be found on the selected diskette which satisfy the directory request, then the message "NOT FOUND" is typed at the console.

## 4.3. REN ufn1=ufn2 cr

The REN (rename) command allows the user to change the names of files on disk. The file satisfying ufn2 is changed to ufn1. The currently logged disk is assumed to contain the file to rename (ufn1). The CCP also allows the user to type a left-directed arrow instead of the equal sign, if the user's console supports this graphic character. Examples of the REN command are

```
REN X.Y=Q.R           The file Q.R is changed to X.Y.
```

```
REN XYZ.COM=XYZ.XXX   The file XYZ.XXX is changed to XYZ.COM.
```

The operator can precede either ufn1 or ufn2 (or both) by an optional drive address. Given that ufn1 is preceded by a drive name, then ufn2 is assumed to exist on the same drive as ufn1. Similarly, if ufn2 is preceded by a drive name, then ufn1 is assumed to reside on that drive as well. If both ufn1 and ufn2 are preceded by drive names, then the same drive must be



specified in both cases. The following REN commands illustrate this format.

REN A:X.ASM = Y.ASM	The file Y.ASM is changed to X.ASM on drive A.
REN B:ZAP.BAS=ZOT.BAS	The file ZOT.BAS is changed to ZAP.BAS on drive B.
REN B:A.ASM = B:A.BAK	The file A.BAK is renamed to A.ASM on drive B.

If the file ufn1 is already present, the REN command will respond with the error "FILE EXISTS" and not perform the change. If ufn2 does not exist on the specified diskette, then the message "NOT FOUND" is printed at the console.

#### 4.4. SAVE n ufn cr

The SAVE command places n pages (256-byte blocks) onto disk from the TPA and names this file ufn. In the CP/M distribution system, the TPA starts at 100H (hexadecimal), which is the second page of memory. Thus, if the user's program occupies the area from 100H through 2FFH, the SAVE command must specify 2 pages of memory. The machine code file can be subsequently loaded and executed. Examples are:

SAVE 3 X.COM	Copies 100H through 3FFH to X.COM.
SAVE 40 Q	Copies 100H through 28FFH to Q (note that 28 is the page count in 28FFH, and that 28H = 2*16+8 = 40 decimal).
SAVE 4 X.Y	Copies 100H through 4FFH to X.Y.

The SAVE command can also specify a disk drive in the afn portion of the command, as shown below.

SAVE 10 B:ZOT.COM	Copies 10 pages (100H through 0AFFH) to the file ZOT.COM on drive B.
-------------------	--

#### 4.5. TYPE ufn cr

The TYPE command displays the contents of the ASCII source file ufn on the currently logged disk at the console device. Valid TYPE commands are

TYPE X.Y

TYPE X.PLM

TYPE XXX

The TYPE command expands tabs (ctrl-I characters), assuming tab positions are set at every eighth column. The ufn can also reference a drive name as shown below.

TYPE B:X.PRN

The file X.PRN from drive B is displayed.

## 5. LINE EDITING AND OUTPUT CONTROL.

The CCP allows certain line editing functions while typing command lines.

rubout	Delete and echo the last character typed at the console.
ctl-U	Delete the entire line typed at the console.
ctl-X	(Same as ctl-U)
ctl-R	Retype current command line: types a "clean line" following character deletion with rubouts.
ctl-E	Physical end of line: carriage is returned, but line is not sent until the carriage return key is depressed.
ctl-C	CP/M system reboot (warm start)
ctl-Z	End input from the console (used in PIP and ED).

The control functions ctl-P and ctl-S affect console output as shown below.

ctl-P	Copy all subsequent console output to the currently assigned list device (see the STAT command). Output is sent to both the list device and the console device until the next ctl-P is typed.
ctl-S	Stop the console output temporarily. Program execution and output continue when the next character is typed at the console (e.g., another ctl-S). This feature is used to stop output on high speed consoles, such as CRT's, in order to view a segment of output before continuing.

Note that the ctl-key sequences shown above are obtained by depressing the control and letter keys simultaneously. Further, CCP command lines can generally be up to 255 characters in length; they are not acted upon until the carriage return key is typed.

## 6. TRANSIENT COMMANDS.

Transient commands are loaded from the currently logged disk and executed in the TPA. The transient commands defined for execution under the CCP are shown below. Additional functions can easily be defined by the user (see the LOAD command definition).

STAT	List the number of bytes of storage remaining on the currently logged disk, provide statistical information about particular files, and display or alter device assignment.
ASM	Load the CP/M assembler and assemble the specified program from disk.
LOAD	Load the file in Intel "hex" machine code format and produce a file in machine executable form which can be loaded into the TPA (this loaded program becomes a new command under the CCP).
DDT	Load the CP/M debugger into TPA and start execution.
PIP	Load the Peripheral Interchange Program for subsequent disk file and peripheral transfer operations.
ED	Load and execute the CP/M text editor program.
SYSGEN	Create a new CP/M system diskette.
SUBMIT	Submit a file of commands for batch processing.
DUMP	Dump the contents of a file in hex.
MOVCPM	Regenerate the CP/M system for a particular memory size.

Transient commands are specified in the same manner as built-in commands, and additional commands can be easily defined by the user. As an added convenience, the transient command can be preceded by a drive name, which causes the transient to be loaded from the specified drive into the TPA for execution. Thus, the command

B:STAT

causes CP/M to temporarily "log in" drive B for the source of the STAT transient, and then return to the original logged disk for subsequent processing.

The basic transient commands are listed in detail below.

### 6.1. STAT cr

The STAT command provides general statistical information about file storage and device assignment. It is initiated by typing one of the following forms:

```
STAT cr
STAT "command line" cr
```

Special forms of the "command line" allow the current device assignment to be examined and altered as well. The various command lines which can be specified are shown below, with an explanation of each form shown to the right.

STAT cr

If the user types an empty command line, the STAT transient calculates the storage remaining on all active drives, and prints a message

```
x: R/W, SPACE: nnnK
```

or

```
x: R/O, SPACE: nnnK
```

for each active drive x, where R/W indicates the drive may be read or written, and R/O indicates the drive is read only (a drive becomes R/O by explicitly setting it to read only, as shown below, or by inadvertently changing diskettes without performing a warm start). The space remaining on the diskette in drive x is given in kilobytes by nnn.

STAT x: cr

If a drive name is given, then the drive is selected before the storage is computed. Thus, the command "STAT B:" could be issued while logged into drive A, resulting in the message

```
BYTES REMAINING ON B: nnnK
```

STAT afn cr

The command line can also specify a set of files to be scanned by STAT. The files which satisfy afn are listed in alphabetical order, with storage requirements for each file under the heading

```
RECS BYTS EX D:FILENAME.TYP
rrrr bbbK ee d:pppppppp.sss
```

where rrrr is the number of 128-byte records

allocated to the file, bbb is the number of kilobytes allocated to the file ( $bbb = rrrr * 128 / 1024$ ), ee is the number of 16K extensions ( $ee = bbb / 16$ ), d is the drive name containing the file (A...Z), pppppppp is the (up to) eight-character primary file name, and sss is the (up to) three-character secondary name. After listing the individual files, the storage usage is summarized.

STAT x:afn cr

As a convenience, the drive name can be given ahead of the afn. In this case, the specified drive is first selected, and the form "STAT afn" is executed.

STAT x:=R/O cr

This form sets the drive given by x to read-only, which remains in effect until the next warm or cold start takes place. When a disk is read-only, the message

BDOS ERR ON x: READ ONLY

will appear if there is an attempt to write to the read-only disk x. CP/M waits until a key is depressed before performing an automatic warm start (at which time the disk becomes R/W).

The STAT command also allows control over the physical to logical device assignment (see the IOBYTE function described in the manuals "CP/M Interface Guide" and "CP/M System Alteration Guide"). In general, there are four logical peripheral devices which are, at any particular instant, each assigned to one of several physical peripheral devices. The four logical devices are named:

CON:	The system console device (used by CCP for communication with the operator)
RDR:	The paper tape reader device
PUN:	The paper tape punch device
LST:	The output list device

The actual devices attached to any particular computer system are driven by subroutines in the BIOS portion of CP/M. Thus, the logical RDR: device, for example, could actually be a high speed reader, Teletype reader, or cassette tape. In order to allow some flexibility in device naming and assignment, several physical devices are defined, as shown below:

TTY:	Teletype device (slow speed console)
CRT:	Cathode ray tube device (high speed console)
BAT:	Batch processing (console is current RDR:, output goes to current LST: device)
UC1:	User-defined console
PTR:	Paper tape reader (high speed reader)
UR1:	User-defined reader #1
UR2:	User-defined reader #2
PTP:	Paper tape punch (high speed punch)
UP1:	User-defined punch #1
UP2:	User-defined punch #2
LPT:	Line printer
UL1:	User-defined list device #1

It must be emphasized that the physical device names may or may not actually correspond to devices which the names imply. That is, the PTP: device may be implemented as a cassette write operation, if the user wishes. The exact correspondence and driving subroutine is defined in the BIOS portion of CP/M. In the standard distribution version of CP/M, these devices correspond to their names on the MDS 800 development system.

The possible logical to physical device assignments can be displayed by typing

```
STAT VAL: cr
```

The STAT prints the possible values which can be taken on for each logical device:

```
CON. = TTY: CRT: BAT: UC1:
RDR: = TTY: PTR: UR1: UR2:
PUN: = TTY: PTP: UP1: UP2:
LST: = TTY: CRT: LPT: UL1:
```

In each case, the logical device shown to the left can take any of the four physical assignments shown to the right on each line. The current logical to physical mapping is displayed by typing the command

```
STAT DEV: cr
```

which produces a listing of each logical device to the left, and the current corresponding physical device to the right. For example, the list might appear as follows:

```
CON: = CRT:
RDR: = URL:
PUN: = PTP:
LST: = TTY:
```

The current logical to physical device assignment can be changed by typing a STAT command of the form

```
STAT ldl = pdl, ld2 = pd2 , ... , ldn = pdn cr
```

where ldl through ldn are logical device names, and pdl through pdn are compatible physical device names (i.e., ldi and pdi appear on the same line in the "VAL:" command shown above). The following are valid STAT commands which change the current logical to physical device assignments:

```
STAT CON:=CRT: cr
STAT PUN: = TTY: ,LST:=LPT: , RDR:=TTY: cr
```

## 6.2. ASM ufn cr

The ASM command loads and executes the CP/M 8080 assembler. The ufn specifies a source file containing assembly language statements where the secondary name is assumed to be ASM, and thus is not specified. The following ASM commands are valid:

```
ASM X
```

```
ASM GAMMA
```

The two-pass assembler is automatically executed. If assembly errors occur during the second pass, the errors are printed at the console.

The assembler produces a file

```
x.PRN
```

where x is the primary name specified in the ASM command. The PRN file contains a listing of the source program (with imbedded tab characters if present in the source program), along with the machine code generated for each statement and diagnostic error messages, if any. The PRN file can be listed



at the console using the TYPE command, or sent to a peripheral device using PIP (see the PIP command structure below). Note also that the PRN file contains the original source program, augmented by miscellaneous assembly information in the leftmost 16 columns (program addresses and hexadecimal machine code, for example). Thus, the PRN file can serve as a backup for the original source file: if the source file is accidentally removed or destroyed, the PRN file can be edited (see the ED operator's guide) by removing the leftmost 16 characters of each line (this can be done by issuing a single editor "macro" command). The resulting file is identical to the original source file and can be renamed (REN) from PRN to ASM for subsequent editing and assembly. The file

x.HEX

is also produced which contains 8080 machine language in Intel "hex" format suitable for subsequent loading and execution (see the LOAD command). For complete details of CP/M's assembly language program, see the "CP/M Assembler Language (ASM) User's Guide."

Similar to other transient commands, the source file for assembly can be taken from an alternate disk by prefixing the assembly language file name by a disk drive name. Thus, the command

ASM B:ALPHA cr

loads the assembler from the currently logged drive and operates upon the source program ALPHA.ASM on drive B. The HEX and PRN files are also placed on drive B in this case.

### 6.3. LOAD ufn cr

The LOAD command reads the file ufn, which is assumed to contain "hex" format machine code, and produces a memory image file which can be subsequently executed. The file name ufn is assumed to be of the form

x.HEX

and thus only the name x need be specified in the command. The LOAD command creates a file named

x.COM

which marks it as containing machine executable code. The file is actually loaded into memory and executed when the user types the file name x immediately after the prompting character ">" printed by the CCP.

In general, the CCP reads the name x following the prompting character and looks for a built-in function name. If no function name is found, the CCP searches the system disk directory for a file by the name

## x.COM

If found, the machine code is loaded into the TPA, and the program executes. Thus, the user need only LOAD a hex file once; it can be subsequently executed any number of times by simply typing the primary name. In this way, the user can "invent" new commands in the CCP. (Initialized disks contain the transient commands as COM files, which can be deleted at the user's option.) The operation can take place on an alternate drive if the file name is prefixed by a drive name. Thus,

### LOAD B:BETA

brings the LOAD program into the TPA from the currently logged disk and operates upon drive B after execution begins.

It must be noted that the BETA.HEX file must contain valid Intel format hexadecimal machine code records (as produced by the ASM program, for example) which begin at 100H, the beginning of the TPA. Further, the addresses in the hex records must be in ascending order; gaps in unfilled memory regions are filled with zeroes by the LOAD command as the hex records are read. Thus, LOAD must be used only for creating CP/M standard "COM" files which operate in the TPA. Programs which occupy regions of memory other than the TPA can be loaded under DDT.

## 6.4. PIP cr

PIP is the CP/M Peripheral Interchange Program which implements the basic media conversion operations necessary to load, print, punch, copy, and combine disk files. The PIP program is initiated by typing one of the following forms

- (1) PIP cr
- (2) PIP "command line" cr

In both cases, PIP is loaded into the TPA and executed. In case (1), PIP reads command lines directly from the console, prompted with the "\*" character, until an empty command line is typed (i.e., a single carriage return is issued by the operator). Each successive command line causes some media conversion to take place according to the rules shown below. Form (2) of the PIP command is equivalent to the first, except that the single command line given with the PIP command is automatically executed, and PIP terminates immediately with no further prompting of the console for input command lines. The form of each command line is

destination = source#1, source#2, ... , source#n cr

where "destination" is the file or peripheral device to receive the data, and

"source#1, ..., source#n" represents a series of one or more files or devices which are copied from left to right to the destination.

When multiple files are given in the command line (i.e, n > 1), the individual files are assumed to contain ASCII characters, with an assumed CP/M end-of-file character (ctl-Z) at the end of each file (see the O parameter to override this assumption). The equal symbol (=) can be replaced by a left-oriented arrow, if your console supports this ASCII character, to improve readability. Lower case ASCII alphabets are internally translated to upper case to be consistent with CP/M file and device name conventions. Finally, the total command line length cannot exceed 255 characters (ctl-E can be used to force a physical carriage return for lines which exceed the console width).

The destination and source elements can be unambiguous references to CP/M source files, with or without a preceding disk drive name. That is, any file can be referenced with a preceding drive name (A:, B:, C:, or D:) which defines the particular drive where the file may be obtained or stored. When the drive name is not included, the currently logged disk is assumed. Further, the destination file can also appear as one or more of the source files, in which case the source file is not altered until the entire concatenation is complete. If the destination file already exists, it is removed if the command line is properly formed (it is not removed if an error condition arises). The following command lines (with explanations to the right) are valid as input to PIP:

X = Y cr	Copy to file X from file Y, where X and Y are unambiguous file names; Y remains unchanged.
X = Y,Z cr	Concatenate files Y and Z and copy to file X, with Y and Z unchanged.
X.ASM=Y.ASM,Z.ASM,FIN.ASM cr	Create the file X.ASM from the concatenation of the Y, Z, and FIN files with type ASM.
NEW.ZOT = B:OLD.ZAP cr	Move a copy of OLD.ZAP from drive B to the currently logged disk; name the file NEW.ZOT.
B:A.U = B:B.V,A:C.W,D:X cr	Concatenate file B.V from drive B with C.W from drive A and D.X. from the logged disk; create the file A.U on drive B.

For more convenient use, PIP allows abbreviated commands for transferring files between disk drives. The abbreviated forms are

PIP x:=afn cr

PIP x:=y:afn cr

PIP ufn = y: cr

PIP x:ufn = y: cr

The first form copies all files from the currently logged disk which satisfy the afn to the same file names on drive x (x = A...Z). The second form is equivalent to the first, where the source for the copy is drive y (y = A...Z). The third form is equivalent to the command "PIP ufn=y:ufn cr" which copies the file given by ufn from drive y to the file ufn on drive x. The fourth form is equivalent to the third, where the source disk is explicitly given by y.

Note that the source and destination disks must be different in all of these cases. If an afn is specified, PIP lists each ufn which satisfies the afn as it is being copied. If a file exists by the same name as the destination file, it is removed upon successful completion of the copy, and replaced by the copied file.

The following PIP commands give examples of valid disk-to-disk copy operations:

B:=\*.COM cr

Copy all files which have the secondary name "COM" to drive B from the current drive.

A:=B:ZAP.\* cr

Copy all files which have the primary name "ZAP" to drive A from drive B.

ZAP.ASM=B: cr

Equivalent to ZAP.ASM=B:ZAP.ASM

B:ZOT.COM=A: cr

Equivalent to B:ZOT.COM=A:ZOT.COM

B:=GAMMA.BAS cr

Same as B:GAMMA.BAS=GAMMA.BAS

B:=A:GAMMA.BAS cr

Same as B:GAMMA.BAS=A:GAMMA.BAS

PIP also allows reference to physical and logical devices which are attached to the CP/M system. The device names are the same as given under the STAT command, along with a number of specially named devices. The logical devices given in the STAT command are

CON: (console), RDR: (reader), PUN: (punch), and LST: (list)

while the physical devices are

TTY: (console, reader, punch, or list)  
 CRT: (console, or list),      UC1: (console)  
 PTR: (reader), UR1: (reader), UR2: (reader)  
 PTP: (punch), UP1: (punch), UP2: (punch)  
 LPT: (list),      UL1: (list)

(Note that the "BAT:" physical device is not included, since this assignment is used only to indicate that the RDR: and LST: devices are to be used for console input/output.)

The RDR, LST, FUN, and CON devices are all defined within the BIOS portion of CP/M, and thus are easily altered for any particular I/O system. (The current physical device mapping is defined by IOBYTE; see the "CP/M Interface Guide" for a discussion of this function). The destination device must be capable of receiving data (i.e., data cannot be sent to the punch), and the source devices must be capable of generating data (i.e., the LST: device cannot be read).

The additional device names which can be used in PIP commands are

NUL:              Send 40 "nulls" (ASCII 0's) to the device  
                   (this can be issued at the end of punched output).  
  
 EOF:              Send a CP/M end-of-file (ASCII ctl-Z) to the  
                   destination device (sent automatically at the  
                   end of all ASCII data transfers through PIP).  
  
 INP:              Special PIP input source which can be "patched"  
                   into the PIP program itself: PIP gets the input  
                   data character-by-character by CALLing location  
                   103H, with data returned in location 109H (parity  
                   bit must be zero).  
  
 OUT:              Special PIP output destination which can be  
                   patched into the PIP program: PIP CALLs location  
                   106H with data in register C for each character  
                   to transmit. Note that locations 109H through  
                   1FFH of the PIP memory image are not used and  
                   can be replaced by special purpose drivers using  
                   DDT (see the DDT operator's manual).  
  
 PRN:              Same as LST:, except that tabs are expanded at  
                   every eighth character position, lines are  
                   numbered, and page ejects are inserted every 60  
                   lines, with an initial eject (same as [t8np]).

File and device names can be interspersed in the PIP commands. In each case, the specific device is read until end-of-file (ctl-Z for ASCII files, and a real end of file for non-ASCII disk files). Data from each device or file is concatenated from left to right until the last data source has been

read. The destination device or file is written using the data from the source files, and an end-of-file character (ctl-Z) is appended to the result for ASCII files. Note if the destination is a disk file, then a temporary file is created (\$\$\$ secondary name) which is changed to the actual file name only upon successful completion of the copy. Files with the extension "COM" are always assumed to be non-ASCII.

The copy operation can be aborted at any time by depressing any key on the keyboard (a rubout suffices). PIP will respond with the message "ABORTED" to indicate that the operation was not completed. Note that if any operation is aborted, or if an error occurs during processing, PIP removes any pending commands which were set up while using the SUBMIT command.

It should also be noted that PIP performs a special function if the destination is a disk file with type "HEX" (an Intel hex formatted machine code file), and the source is an external peripheral device, such as a paper tape reader. In this case, the PIP program checks to ensure that the source file contains a properly formed hex file, with legal hexadecimal values and checksum records. When an invalid input record is found, PIP reports an error message at the console and waits for corrective action. It is usually sufficient to open the reader and rerun a section of the tape (pull the tape back about 20 inches). When the tape is ready for the re-read, type a single carriage return at the console, and PIP will attempt another read. If the tape position cannot be properly read, simply continue the read (by typing a return following the error message), and enter the record manually with the ED program after the disk file is constructed. For convenience, PIP allows the end-of-file to be entered from the console if the source file is a RDR: device. In this case, the PIP program reads the device and monitors the keyboard. If ctl-Z is typed at the keyboard, then the read operation is terminated normally.

Valid PIP commands are shown below.

PIP LST: = X.PRN cr	Copy X.PRN to the LST device and terminate the PIP program.
PIP cr	Start PIP for a sequence of commands (PIP prompts with "***").
*CON:=X.ASM,Y.ASM,Z.ASM cr	Concatenate three ASM files and copy to the CON device.
*X.HEX=CON:,Y.HEX,PTR: cr	Create a HEX file by reading the CON (until a ctl-Z is typed), followed by data from Y.HEX, followed by data from PTR until a ctl-Z is encountered.
*cr	Single carriage return stops PIP.

PIP PUN:=NUL:,X.ASM,EOF:,NUL: cr

Send 40 nulls to the punch device; then copy the X.ASM file to the punch, followed by an end-of-file (ctl-Z) and 40 more null characters.

The user can also specify one or more PIP parameters, enclosed in left and right square brackets, separated by zero or more blanks. Each parameter affects the copy operation, and the enclosed list of parameters must immediately follow the affected file or device. Generally, each parameter can be followed by an optional decimal integer value (the S and Q parameters are exceptions). The valid PIP parameters are listed below.

- B Block mode transfer: data is buffered by PIP until an ASCII x-off character (ctl-S) is received from the source device. This allows transfer of data to a disk file from a continuous reading device, such as a cassette reader. Upon receipt of the x-off, PIP clears the disk buffers and returns for more input data. The amount of data which can be buffered is dependent upon the memory size of the host system (PIP will issue an error message if the buffers overflow).
- Dn Delete characters which extend past column n in the transfer of data to the destination from the character source. This parameter is used most often to truncate long lines which are sent to a (narrow) printer or console device.
- E Echo all transfer operations to the console as they are being performed.
- F Filter form feeds from the file. All imbedded form feeds are removed. The P parameter can be used simultaneously to insert new form feeds.
- H Hex data transfer: all data is checked for proper Intel hex file format. Non-essential characters between hex records are removed during the copy operation. The console will be prompted for corrective action in case errors occur.
- I Ignore ":00" records in the transfer of Intel hex format file (the I parameter automatically sets the H parameter).
- L Translate upper case alphabets to lower case.
- N Add line numbers to each line transferred to the destination starting at one, and incrementing by 1. Leading zeroes are suppressed, and the number is followed by a colon. If N2 is specified, then leading zeroes are included, and a tab is inserted following the number. The tab is expanded if T is

set.

- O Object file (non-ASCII) transfer: the normal CP/M end of file is ignored.
  - Pn Include page ejects at every n lines (with an initial page eject). If n = 1 or is excluded altogether, page ejects occur every 60 lines. If the F parameter is used, form feed suppression takes place before the new page ejects are inserted.
  - Qs<sup>f</sup>z Quit copying from the source device or file when the string s (terminated by ctl-Z) is encountered.
  - Ss<sup>f</sup>z Start copying from the source device when the string s is encountered (terminated by ctl-Z). The S and Q parameters can be used to "abstract" a particular section of a file (such as a subroutine). The start and quit strings are always included in the copy operation.
- NOTE - the strings following the s and q parameters are translated to upper case by the CCP if form (2) of the PIP command is used. Form (1) of the PIP invocation, however, does not perform the automatic upper case translation.
- (1) PIP cr
  - (2) PIP "command line" cr
- Tn Expand tabs (ctl-I characters) to every nth column during the transfer of characters to the destination from the source.
  - U Translate lower case alphabets to upper case during the the copy operation.
  - V Verify that data has been copied correctly by rereading after the write operation (the destination must be a disk file).
  - Z Zero the parity bit on input for each ASCII character.

The following are valid PIP commands which specify parameters in the file transfer:

- |                         |  |
|-------------------------|--|
| PIP X.ASM=B:[v] cr      | Copy X.ASM from drive B to the current drive and verify that the data was properly copied.   |
| PIP LPT:=X.ASM[nt8u] cr | Copy X.ASM to the LPT: device; number each line, expand tabs to every eighth column, and translate lower case alphabets to upper case. |



PIP PUN:=X.HEX[i],Y.ZOT[h] cr First copy X.HEX to the PUN: device and ignore the trailing ":00" record in X.HEX; then continue the transfer of data by reading Y.ZOT, which contains hex records, including any ":00" records which it contains.

PIP X.LIB = Y.ASM [ sSUBRl:↑z αJMP L3↑z ] cr Copy from the file Y.ASM into the file X.LIB. Start the copy when the string "SUBRl:" has been found, and quit copying after the string "JMP L3" is encountered.

PIP PRN:=X.ASM[p50] Send X.ASM to the LST: device, with line numbers, tabs expanded to every eighth column, and page ejects at every 50th line. Note that nt8p60 is the assumed parameter list for a PRN file; p50 overrides the default value.

## 6.5. ED ufn cr

The ED program is the CP/M system context editor, which allows creation and alteration of ASCII files in the CP/M environment. Complete details of operation are given the ED user's manual, "ED: a Context Editor for the CP/M Disk System." In general, ED allows the operator to create and operate upon source files which are organized as a sequence of ASCII characters, separated by end-of-line characters (a carriage-return line-feed sequence). There is no practical restriction on line length (no single line can exceed the size of the working memory), which is instead defined by the number of characters typed between cr's. The ED program has a number of commands for character string searching, replacement, and insertion, which are useful in the creation and correction of programs or text files under CP/M. Although the CP/M has a limited memory work space area (approximately 5000 characters in a 16K CP/M system), the file size which can be edited is not limited, since data is easily "paged" through this work area.

Upon initiation, ED creates the specified source file, if it does not exist, and opens the file for access. The programmer then "appends" data from the source file into the work area, if the source file already exists (see the A command), for editing. The appended data can then be displayed, altered, and written from the work area back to the disk (see the W command). Particular points in the program can be automatically paged and located by context (see the N command), allowing easy access to particular portions of a large file.

Given that the operator has typed

ED X.ASM cr

the ED program creates an intermediate work file with the name

X.\$\$\$

to hold the edited data during the ED run. Upon completion of ED, the X.ASM file (original file) is renamed to X.BAK, and the edited work file is renamed to X.ASM. Thus, the X.BAK file contains the original (unedited) file, and the X.ASM file contains the newly edited file. The operator can always return to the previous version of a file by removing the most recent version, and renaming the previous version. Suppose, for example, that the current X.ASM file was improperly edited; the sequence of CCP command shown below would reclaim the backup file.

DIR X.*	Check to see that BAK file is available.
ERA X.ASM	Erase most recent version.
REN X.ASM=X.BAK	Rename the BAK file to ASM.

Note that the operator can abort the edit at any point (reboot, power failure, ctl-C, or Q command) without destroying the original file. In this case, the BAK file is not created, and the original file is always intact.

The ED program also allows the user to "ping-pong" the source and create backup files between two disks. The form of the ED command in this case is

ED ufn d:

where ufn is the name of a file to edit on the currently logged disk, and d is the name of an alternate drive. The ED program reads and processes the source file, and writes the new file to drive d, using the name ufn. Upon completion of processing, the original file becomes the backup file. Thus, if the operator is addressing disk A, the following command is valid:

ED X.ASM B:

which edits the file X.ASM on drive A, creating the new file X.\$\$\$ on drive B. Upon completion of a successful edit, A:X.ASM is renamed to A:X.BAK, and B:X.\$\$\$ is renamed to B:X.ASM. For user convenience, the currently logged disk becomes drive B at the end of the edit. Note that if a file by the name B:X.ASM exists before the editing begins, the message

FILE EXISTS

is printed at the console as a precaution against accidentally destroying a source file. In this case, the operator must first ERASE the existing file and then restart the edit operation.

Similar to other transient commands, editing can take place on a drive different from the currently logged disk by preceding the source file name by a drive name. Examples of valid edit requests are shown below

ED A:X.ASM	Edit the file X.ASM on drive A, with new file and backup on drive A.
ED B:X.ASM A:	Edit the file X.ASM on drive B to the temporary file X.\$\$\$ on drive A. On termination of editing, change X.ASM on drive B to X.BAK, and change X.\$\$\$ on drive A to X.ASM.

#### 6.6. SYSGEN cr

The SYSGEN transient command allows generation of an initialized diskette containing the CP/M operating system. The SYSGEN program prompts the console for commands, with interaction as shown below.

SYSGEN cr	Initiate the SYSGEN program.
SYSGEN VERSION m.m	SYSGEN sign-on message.
SOURCE DRIVE NAME (OR RETURN TO SKIP)	Respond with the drive name (one of the letters A, B, C, or D) of the disk containing a CP/M system; usually A. If a copy of CP/M already exists in memory, due to a MOVCPM command, type a cr only. Typing a drive name x will cause the response:
SOURCE ON x THEN TYPE RETURN	Place a diskette containing the CP/M operating system on drive x (x is one of A, B, C, or D). Answer with cr when ready.
FUNCTION COMPLETE	System is copied to memory. SYSGEN will then prompt with:
DESTINATION DRIVE NAME (OR RETURN TO REBOOT)	If a diskette is being initialized, place the new disk into a drive and answer with the drive name. Otherwise, type a cr and the system will reboot from drive A. Typing drive name x will cause SYSGEN to prompt

with:

DESTINATION ON x THEN TYPE RETURN Place new diskette into drive x; type return when ready.

FUNCTION COMPLETE

New diskette is initialized in drive x.

The "DESTINATION" prompt will be repeated until a single carriage return is typed at the console, so that more than one disk can be initialized.

Upon completion of a successful system generation, the new diskette contains the operating system, and only the built-in commands are available. A factory-fresh IBM-compatible diskette appears to CP/M as a diskette with an empty directory; therefore, the operator must copy the appropriate COM files from an existing CP/M diskette to the newly constructed diskette using the PIP transient.

The user can copy all files from an existing diskette by typing the PIP command

```
PIP B: = A: *.*[v] cr
```

which copies all files from disk drive A to disk drive B, and verifies that each file has been copied correctly. The name of each file is displayed at the console as the copy operation proceeds.

It should be noted that a SYSGEN does not destroy the files which already exist on a diskette; it results only in construction of a new operating system. Further, if a diskette is being used only on drives B through D, and will never be the source of a bootstrap operation on drive A, the SYSGEN need not take place. In fact, a new diskette needs absolutely no initialization to be used with CP/M.

#### 6.7. SUBMIT ufn parm#1 ... parm#n cr

The SUBMIT command allows CP/M commands to be batched together for automatic processing. The ufn given in the SUBMIT command must be the filename of a file which exists on the currently logged disk, with an assumed file type of "SUB." The SUB file contains CP/M prototype commands, with possible parameter substitution. The actual parameters parm#1 ... parm#n are substituted into the prototype commands, and, if no errors occur, the file of substituted commands are processed sequentially by CP/M.

The prototype command file is created using the ED program, with interspersed "\$" parameters of the form

\$1 \$2 \$3 ... \$n

corresponding to the number of actual parameters which will be included when the file is submitted for execution. When the SUBMIT transient is executed, the actual parameters parm#1 ... parm#n are paired with the formal parameters \$1 ... \$n in the prototype commands. If the number of formal and actual parameters does not correspond, then the submit function is aborted with an error message at the console. The SUBMIT function creates a file of substituted commands with the name

\$\$\$SUB

on the logged disk. When the system reboots (at the termination of the SUBMIT), this command file is read by the CCP as a source of input, rather than the console. If the SUBMIT function is performed on any disk other than drive A, the commands are not processed until the disk is inserted into drive A and the system reboots. Further, the user can abort command processing at any time by typing a rubout when the command is read and echoed. In this case, the \$\$\$SUB file is removed, and the subsequent commands come from the console. Command processing is also aborted if the CCP detects an error in any of the commands. Programs which execute under CP/M can abort processing of command files when error conditions occur by simply erasing any existing \$\$\$SUB file.

In order to introduce dollar signs into a SUBMIT file, the user may type a "\$\$" which reduces to a single "\$" within the command file. Further, an up-arrow symbol "↑" may precede an alphabetic character x, which produces a single ctl-x character within the file.

The last command in a SUB file can initiate another SUB file, thus allowing chained batch commands.

Suppose the file ASMBL.SUB exists on disk and contains the prototype commands

```
ASM $1
DIR $1.*
ERA *.BAK
PIP $2:=$1.PRN
ERA $1.PRN
```

and the command

```
SUBMIT ASMBL X PRN cr
```

is issued by the operator. The SUBMIT program reads the ASMBL.SUB file, substituting "X" for all occurrences of \$1 and "PRN" for all occurrences of \$2, resulting in a \$\$\$SUB file containing the commands

```
ASM X
DIR X.*
ERA *.BAK
PIP PRN:=X.PRN
ERA X.PRN
```

which are executed in sequence by the CCP.

The SUBMIT function can access a SUB file which is on an alternate drive by preceding the file name by a drive name. Submitted files are only acted upon, however, when they appear on drive A. Thus, it is possible to create a submitted file on drive B which is executed at a later time when it is inserted in drive A.

#### 6.8. DUMP ufn cr

The DUMP program types the contents of the disk file (ufn) at the console in hexadecimal form. The file contents are listed sixteen bytes at a time, with the absolute byte address listed to the left of each line in hexadecimal. Long typeouts can be aborted by pushing the rubout key during printout. (The source listing of the DUMP program is given in the "CP/M Interface Guide" as an example of a program written for the CP/M environment.)

#### 6.9. MOVCPM cr

The MOVCPM program allows the user to reconfigure the CP/M system for any particular memory size. Two optional parameters may be used to indicate (1) the desired size of the new system and (2) the disposition of the new system at program termination. If the first parameter is omitted or a "\*" is given, the MOVCPM program will reconfigure the system to its maximum size, based upon the kilobytes of contiguous RAM in the host system (starting at 0000H). If the second parameter is omitted, the system is executed, but not permanently recorded; if "\*" is given, the system is left in memory, ready for a SYSGEN operation. The MOVCPM program relocates a memory image of CP/M and places this image in memory in preparation for a system generation operation. The command forms are:

```
MOVCPM cr
```

Relocate and execute CP/M for management of the current memory configuration (memory is examined for contiguous RAM, starting at 100H). Upon completion of the relocation, the new system is executed but not permanently recorded on the diskette. The system which is constructed contains a BIOS for the Intel MDS 800.

MOVCPM n cr	Create a relocated CP/M system for management of an n kilobyte system (n must be in the range 16 to 64), and execute the system, as described above.
MOVCPM * * cr	Construct a relocated memory image for the current memory configuration, but leave the memory image in memory, in preparation for a SYSGEN operation.
MOVCPM n * cr	Construct a relocated memory image for an n kilobyte memory system, and leave the memory image in preparation for a SYSGEN operation.

The command

MOVCPM \* \*

for example, constructs a new version of the CP/M system and leaves it in memory, ready for a SYSGEN operation. The message

READY FOR "SYSGEN" OR  
"SAVE 32 CPMxx.COM"

is printed at the console upon completion, where xx is the current memory size in kilobytes. The operator can then type

SYSGEN cr	Start the system generation.
SOURCE DRIVE NAME (OR RETURN TO SKIP)	Respond with a cr to skip the CP/M read operation since the system is already in memory as a result of the previous MOVCPM operation.
DESTINATION DRIVE NAME (OR RETURN TO REBOOT)	Respond with B to write new system to the diskette in drive B. SYSGEN will prompt with:
DESTINATION ON B, THEN TYPE RETURN	Ready the fresh diskette on drive B and type a return when ready.

Note that if you respond with "A" rather than "B" above, the system will be written to drive A rather than B. SYSGEN will continue to type the prompt:

DESTINATION DRIVE NAME (OR RETURN TO REBOOT)

until the operator responds with a single carriage return, which stops the

**SYSGEN program with a system reboot.**

The user can then go through the reboot process with the old or new diskette. Instead of performing the SYSGEN operation, the user could have typed

**SAVE 32 CPMxx.COM**

at the completion of the MOVCPM function, which would place the CP/M memory image on the currently logged disk in a form which can be "patched." This is necessary when operating in a non-standard environment where the BIOS must be altered for a particular peripheral device configuration, as described in the "CP/M System Alteration Guide."

Valid MOVCPM commands are given below:

**MOVCPM 48 cr**                      Construct a 48K verskon of CP/M and start execution.

**MOVCPM 48 \* cr**                    Construct a 48K version of CP/M in preparation for permanent recording; response is

**READY FOR "SYSGEN" OR  
"SAVE 32CPM48.COM"**

**MOVCPM \* \* cr**                    Construct a maximum memory version of CP/M and start execution.

It is important to note that the newly created system is serialized with the number attached to the original diskette and is subject to the conditions of the Digital Research Software Licensing Agreement.



## 7. BDOS ERROR MESSAGES.

There are three error situations which the Basic Disk Operating System intercepts during file processing. When one of these conditions is detected, the BDOS prints the message:

BDOS ERR ON x: error

where x is the drive name, and "error" is one of the three error messages:

BAD SECTOR  
SELECT  
READ ONLY

The "BAD SECTOR" message indicates that the disk controller electronics has detected an error condition in reading or writing the diskette. This condition is generally due to a malfunctioning disk controller, or an extremely worn diskette. If you find that your system reports this error more than once a month, you should check the state of your controller electronics, and the condition of your media. You may also encounter this condition in reading files generated by a controller produced by a different manufacturer. Even though controllers are claimed to be IBM-compatible, one often finds small differences in recording formats. The MDS-800 controller, for example, requires two bytes of one's following the data CRC byte, which is not required in the IBM format. As a result, diskettes generated by the Intel MDS can be read by almost all other IBM-compatible systems, while disk files generated on other manufacturer's equipment will produce the "BAD SECTOR" message when read by the MDS. In any case, recovery from this condition is accomplished by typing a `ctl-C` to reboot (this is the safest!), or a return, which simply ignores the bad sector in the file operation. Note, however, that typing a return may destroy your diskette integrity if the operation is a directory write, so make sure you have adequate backups in this case.

The "SELECT" error occurs when there is an attempt to address a drive beyond the A through D range. In this case, the value of x in the error message gives the selected drive. The system reboots following any input from the console.

The "READ ONLY" message occurs when there is an attempt to write to a diskette which has been designated as read-only in a STAT command, or has been set to read-only by the BDOS. In general, the operator should reboot CP/M either by using the warm start procedure (`ctl-C`) or by performing a cold start whenever the diskettes are changed. If a changed diskette is to be read but not written, BDOS allows the diskette to be changed without the warm or cold start, but internally marks the drive as read-only. The status of the drive is subsequently changed to read/write if a warm or cold start occurs. Upon issuing this message, CP/M waits for input from the console. An automatic warm start takes place following any input.

## 8. OPERATION OF CP/M ON THE MDS.

This section gives operating procedures for using CP/M on the Intel MDS microcomputer development system. A basic knowledge of the MDS hardware and software systems is assumed.

CP/M is initiated in essentially the same manner as Intel's ISIS operating system. The disk drives are labelled 0 through 3 on the MDS, corresponding to CP/M drives A through D, respectively. The CP/M system diskette is inserted into drive 0, and the BOOT and RESET switches are depressed in sequence. The interrupt 2 light should go on at this point. The space bar is then depressed on the device which is to be taken as the system console, and the light should go out (if it does not, then check connections and baud rates). The BOOT switch is then turned off, and the CP/M signon message should appear at the selected console device, followed by the "A>" system prompt. The user can then issue the various resident and transient commands

The CP/M system can be restarted (warm start) at any time by pushing the INT 0 switch on the front panel. The built-in Intel ROM monitor can be initiated by pushing the INT 7 switch (which generates a RST 7), except when operating under DDT, in which case the DDT program gets control instead.

Diskettes can be removed from the drives at any time, and the system can be shut down during operation without affecting data integrity. Note, however, that the user must not remove a diskette and replace it with another without rebooting the system (cold or warm start), unless the inserted diskette is "read only."

Due to hardware hang-ups or malfunctions, CP/M may type the message

```
BDOS ERR ON x: BAD SECTOR
```

where x is the drive which has a permanent error. This error may occur when drive doors are opened and closed randomly, followed by disk operations, or may be due to a diskette, drive, or controller failure. The user can optionally elect to ignore the error by typing a single return at the console. The error may produce a bad data record, requiring re-initialization of up to 128 bytes of data. The operator can reboot the CP/M system and try the operation again.

Termination of a CP/M session requires no special action, except that it is necessary to remove the diskettes before turning the power off, to avoid random transients which often make their way to the drive electronics.

It should be noted that factory-fresh IBM-compatible diskettes should be used rather than diskettes which have previously been used with any ISIS version. In particular, the ISIS "FORMAT" operation produces non-standard sector numbering throughout the diskette. This non-standard numbering seriously degrades the performance of CP/M, and will operate noticeably slower

than the distribution version. If it becomes necessary to reformat a diskette (which should not be the case for standard diskettes), a program can be written under CP/M which causes the MDS 800 controller to reformat with sequential sector numbering (1-26) on each track.

---

Note: "MDS 800" and "ISIS" are registered trademarks of Intel Corporation.



**CP/M ASSEMBLER (ASM): USER'S GUIDE**

## COPYRIGHT

Copyright (c) 1980 by Exidy Systems, Inc. All rights reserved. No part of this publication may be reproduced, transmitted, transcribed, stored in a retrieval system, or translated into any language, in any form or by any means, electronic, mechanical, magnetic, optical, chemical, manual, or otherwise, without the prior written permission of Exidy Systems, Inc., 1234 Elko Drive, Sunnyvale, California 94086.

Since this manual is tutorial in nature, permission is granted to reproduce or abstract the example procedures and sample programs for the purposes of inclusion within the reader's programs.

## DISCLAIMER

Exidy Systems, Inc. makes no representations or warranties with respect to the contents hereof and specifically disclaims any implied warranties of merchantability or fitness for any particular purpose. Further, Exidy Systems, Inc. reserves the right to revise this publication and to make changes from time to time in the content hereof without obligation of Exidy Systems, Inc. to notify any person of such revision or changes.

## TRADEMARKS

CP/M is a registered trademark of Digital Research.

**CP/M ASSEMBLER (ASM): USER'S GUIDE**

## COPYRIGHT

Copyright (c) 1980 by Exidy Systems, Inc. All rights reserved. No part of this publication may be reproduced, transmitted, transcribed, stored in a retrieval system, or translated into any language, in any form or by any means, electronic, mechanical, magnetic, optical, chemical, manual, or otherwise, without the prior written permission of Exidy Systems, Inc., 1234 Elko Drive, Sunnyvale, California 94086.

Since this manual is tutorial in nature, permission is granted to reproduce or abstract the example procedures and sample programs for the purposes of inclusion within the reader's programs.

## DISCLAIMER

Exidy Systems, Inc. makes no representations or warranties with respect to the contents hereof and specifically disclaims any implied warranties of merchantability or fitness for any particular purpose. Further, Exidy Systems, Inc. reserves the right to revise this publication and to make changes from time to time in the content hereof without obligation of Exidy Systems, Inc. to notify any person of such revision or changes.

## TRADEMARKS

CP/M is a registered trademark of Digital Research.



## Table Of Contents

### CP/M Assembler (ASM): User's Guide

1.	Introduction.....	71
2.	Program Format.....	72
3.	Forming The Operand.....	74
3.1	Labels.....	74
3.2	Numeric Constants.....	74
3.3	Reserved Words.....	75
3.4	String Constants.....	76
3.5	Arithmetic and Logical Operators.....	76
3.6	Precedence Of Operators.....	77
4.	Assembler Directives.....	78
4.1	The ORG Directive.....	78
4.2	The END Directive.....	79
4.3	The EQU Directive.....	79
4.4	The SET Directive.....	80
4.5	The IF And ENDIF Directives.....	80
4.6	The DB Directive.....	81
4.7	The DW Directive.....	82
5.	Operation Codes.....	82
5.1	Jumps, Calls And Returns.....	83
5.2	Immediate Operand Instructions.....	84
5.3	Increment and Decrement Instructions.....	84
5.4	Data Movement Instructions.....	84
5.5	Arithmetic Logic Unit Operations.....	85
5.6	Control Instructions.....	86
6.	Error Messages.....	86
7.	A Sample Session.....	87



## CP/M Assembler User's Guide

### 1. INTRODUCTION.

The CP/M assembler reads assembly language source files from the diskette, and produces 8080 machine language in Intel hex format. The CP/M assembler is initiated by typing

ASM filename

or

ASM filename.parms

In both cases, the assembler assumes there is a file on the diskette with the name

filename.ASM

which contains an 8080 assembly language source file. The first and second forms shown above differ only in that the second form allows parameters to be passed to the assembler to control source file access and hex and print file destinations.

In either case, the CP/M assembler loads, and prints the message

CP/M ASSEMBLER VER n.n

where n.n is the current version number. In the case of the first command, the assembler reads the source file with assumed file type "ASM" and creates two output files

filename.HEX

and

filename.PRN

the "HEX" file contains the machine code corresponding to the original program in Intel hex format, and the "PRN" file contains an annotated listing showing generated machine code, error flags, and source lines. If errors occur during translation, they will be listed in the PRN file as well as at the console

The second command form can be used to redirect input and output files from their defaults. In this case, the "parms" portion of the command is a three letter group which specifies the origin of the source file, the destination of the hex file, and the destination of the print file. The form is

filename.plp2p3

where pl, p2, and p3 are single letters

pl: A,B, ..., Y designates the disk name which contains

		the source file
p2:	A,B, ..., Y	designates the disk name which will receive the hex file
	Z	skips the generation of the hex file
p3:	A,B, ..., Y	designates the disk name which will receive the print file
	X	places the listing at the console
	Z	skips generation of the print file

Thus, the command

```
ASM X.AAA
```

indicates that the source file (X.ASM) is to be taken from disk A, and that the hex (X.HEX) and print (X.PRN) files are to be created also on disk A. This form of the command is implied if the assembler is run from disk A. That is, given that the operator is currently addressing disk A, the above command is equivalent to

```
ASM X
```

The command

```
ASM X.ABX
```

indicates that the source file is to be taken from disk A, the hex file is placed on disk B, and the listing file is to be sent to the console. The command

```
ASM X.BZZ
```

takes the source file from disk B, and skips the generation of the hex and print files (this command is useful for fast execution of the assembler to check program syntax).

The source program format is compatible with both the Intel 8080 assembler (macros are not currently implemented in the CP/M assembler, however), as well as the Processor Technology Software Package #1 assembler. That is, the CP/M assembler accepts source programs written in either format. There are certain extensions in the CP/M assembler which make it somewhat easier to use. These extensions are described below.

## 2. PROGRAM FORMAT.

An assembly language program acceptable as input to the assembler consists of a sequence of statements of the form

```
line#  label  operation  operand  ;comment
```

where any or all of the fields may be present in a particular instance. Each

Assembly language statement is terminated with a carriage return and line feed (the line feed is inserted automatically by the ED program), or with the character "!" which is treated as an end-of-line by the assembler (thus, multiple assembly language statements can be written on the same physical line if separated by exclaim symbols).

The line# is an optional decimal integer value representing the source program line number, which is allowed on any source line to maintain compatibility with the Processor Technology format. In general, these line numbers will be inserted if a line-oriented editor is used to construct the original program, and thus ASM ignores this field if present.

The label field takes the form

                  identifier  
or  
                  identifier:

and is optional, except where noted in particular statement types. The identifier is a sequence of alphanumeric characters (alphabetic and numbers), where the first character is alphabetic. Identifiers can be freely used by the programmer to label elements such as program steps and assembler directives, but cannot exceed 16 characters in length. All characters are significant in an identifier, except for the embedded dollar symbol (\$) which can be used to improve readability of the name. Further, all lower case alphabetic characters are treated as if they were upper case. Note that the ":" following the identifier in a label is optional (to maintain compatibility between Intel and Processor Technology). Thus, the following are all valid instances of labels

x	xy	long\$name
x:	yx1:	longer\$name\$d\$ata:
XLY2	Xlx2	x234\$5678\$9012\$3456:

The operation field contains either an assembler directive, or pseudo operation, or an 8080 machine operation code. The pseudo operations and machine operation codes are described below.

The operand field of the statement, in general, contains an expression formed out of constants and labels, along with arithmetic and logical operations on these elements. Again, the complete details of properly formed expressions are given below.

The comment field contains arbitrary characters following the ";" symbol until the next real or logical end-of-line. These characters are read, listed, and otherwise ignored by the assembler. In order to maintain compatibility with the Processor Technology assembler, the CP/M assembler also treat statements which begin with a "\*" in column one as comment statements, which are listed and ignored in the assembly process. Note that the Processor

Technology assembler has the side effect in its operation of ignoring the characters after the operand field has been scanned. This causes an ambiguous situation when attempting to be compatible with Intel's language, since arbitrary expressions are allowed in this case. Hence, programs which use this side effect to introduce comments, must be edited to place a ";" before these fields in order to assemble correctly.

The assembly language program is formulated as a sequence of statements of the above form, terminated optionally by an END statement. All statements following the END are ignored by the assembler.

### 3. FORMING THE OPERAND.

In order to completely describe the operation codes and pseudo operations, it is necessary to first present the form of the operand field, since it is used in nearly all statements. Expressions in the operand field consist of simple operands (labels, constants, and reserved words), combined in properly formed subexpressions by arithmetic and logical operators. The expression computation is carried out by the assembler as the assembly proceeds. Each expression must produce a 16-bit value during the assembly. Further, the number of significant digits in the result must not exceed the intended use. That is, if an expression is to be used in a byte move immediate instruction, then the most significant 8 bits of the expression must be zero. The restrictions on the expression significance is given with the individual instructions.

#### 3.1. Labels.

As discussed above, a label is an identifier which occurs on a particular statement. In general, the label is given a value determined by the type of statement which it precedes. If the label occurs on a statement which generates machine code or reserves memory space (e.g, a MOV instruction, or a DS pseudo operation), then the label is given the value of the program address which it labels. If the label precedes an EQU or SET, then the label is given the value which results from evaluating the operand field. Except for the SET statement, an identifier can label only one statement.

When a label appears in the operand field, its value is substituted by the assembler. This value can then be combined with other operands and operators to form the operand field for a particular instruction.

#### 3.2. Numeric Constants.

A numeric constant is a 16-bit value in one of several bases. The base, called the radix of the constant, is denoted by a trailing radix indicator. The radix indicators are

B	binary constant (base 2)
O	octal constant (base 8)

Q octal constant (base 8)  
 D decimal constant (base 10)  
 H hexadecimal constant (base 16)

Q is an alternate radix indicator for octal numbers since the letter O is easily confused with the digit 0. Any numeric constant which does not terminate with a radix indicator is assumed to be a decimal constant.

A constant is thus composed as a sequence of digits, followed by an optional radix indicator, where the digits are in the appropriate range for the radix. That is binary constants must be composed of 0 and 1 digits, octal constants can contain digits in the range 0 - 7, while decimal constants contain decimal digits. Hexadecimal constants contain decimal digits as well as hexadecimal digits A (10D), B (11D), C (12D), D (13D), E (14D), and F (15D). Note that the leading digit of a hexadecimal constant must be a decimal digit in order to avoid confusing a hexadecimal constant with an identifier (a leading 0 will always suffice). A constant composed in this manner must evaluate to a binary number which can be contained within a 16-bit counter, otherwise it is truncated on the right by the assembler. Similar to identifiers, imbedded "\$" are allowed within constants to improve their readability. Finally, the radix indicator is translated to upper case if a lower case letter is encountered. The following are all valid instances of numeric constants

1234	1234D	1100B	1111\$0000\$1111\$0000B
1234H	0FFEH	3377O	33\$77\$22Q
3377o	0fe3h	1234d	0ffffh

### 3.3. Reserved Words.

There are several reserved character sequences which have predefined meanings in the operand field of a statement. The names of 8080 registers are given below, which, when encountered, produce the value shown to the right

A	7
B	0
C	1
D	2
E	3
H	4
L	5
M	6
SP	6
PSW	6

(again, lower case names have the same values as their upper case equivalents). Machine instructions can also be used in the operand field, and evaluate to their internal codes. In the case of instructions which require operands, where the specific operand becomes a part of the binary bit pattern

of the instruction (e.g, MOV A,B), the value of the instruction (in this case MOV) is the bit pattern of the instruction with zeroes in the optional fields (e.g, MOV produces 40H).

When the symbol "\$" occurs in the operand field (not imbedded within identifiers and numeric constants) its value becomes the address of the next instruction to generate, not including the instruction contained within the current logical line.

### 3.4. String Constants.

String constants represent sequences of ASCII characters, and are represented by enclosing the characters within apostrophe symbols ('). All strings must be fully contained within the current physical line (thus allowing "!" symbols within strings), and must not exceed 64 characters in length. The apostrophe character itself can be included within a string by representing it as a double apostrophe (the two keystrokes ''), which becomes a single apostrophe when read by the assembler. In most cases, the string length is restricted to either one or two characters (the DB pseudo operation is an exception), in which case the string becomes an 8 or 16 bit value, respectively. Two character strings become a 16-bit constant, with the second character as the low order byte, and the first character as the high order byte.

The value of a character is its corresponding ASCII code. There is no case translation within strings, and thus both upper and lower case characters can be represented. Note however, that only graphic (printing) ASCII characters are allowed within strings. Valid strings are

```
'A'      'AB'      'ab'      'c'
.....  'a'.....  .....  .....
'Walla Walla Wash.'
'She said "Hello" to me.'
'I said "Hello" to her.'
```

### 3.5. Arithmetic and Logical Operators.

The operands described above can be combined in normal algebraic notation using any combination of properly formed operands, operators, and parenthesized expressions. The operators recognized in the operand field are

a + b	unsigned arithmetic sum of a and b
a - b	unsigned arithmetic difference between a and b
+ b	unary plus (produces b)
- b	unary minus (identical to 0 - b)
a * b	unsigned magnitude multiplication of a and b
a / b	unsigned magnitude division of a by b
a MOD b	remainder after a / b
NOT b	logical inverse of b (all 0's become 1's, 1's become 0's), where b is considered a 16-bit value



a AND b	bit-by-bit logical and of a and b
a OR b	bit-by-bit logical or of a and b
a XOR b	bit-by-bit logical exclusive or of a and b
a SHL b	the value which results from shifting a to the left by an amount b, with zero fill
a SHR b	the value which results from shifting a to the right by an amount b, with zero fill

In each case, a and b represent simple operands (labels, numeric constants, reserved words, and one or two character strings), or fully enclosed parenthesized subexpressions such as

```

10+20      10h+37Q      L1 /3      (L2+4) SHR 3
('a' and 5fh) + '0'    ('B'+B) OR (PSW+M)
(1+(2+c)) shr (A-(B+1))

```

Note that all computations are performed at assembly time as 16-bit unsigned operations. Thus, -1 is computed as 0-1 which results in the value 0ffffh (i.e., all 1's). The resulting expression must fit the operation code in which it is used. If, for example, the expression is used in a ADI (add immediate) instruction, then the high order eight bits of the expression must be zero. As a result, the operation "ADI -1" produces an error message (-1 becomes 0ffffh which cannot be represented as an 8 bit value), while "ADI (-1) AND 0FFH" is accepted by the assembler since the "AND" operation zeroes the high order bits of the expression.

### 3.6. Precedence of Operators.

As a convenience to the programmer, ASM assumes that operators have a relative precedence of application which allows the programmer to write expressions without nested levels of parentheses. The resulting expression has assumed parentheses which are defined by the relative precedence. The order of application of operators in unparenthesized expressions is listed below. Operators listed first have highest precedence (they are applied first in an unparenthesized expression), while operators listed last have lowest precedence. Operators listed on the same line have equal precedence, and are applied from left to right as they are encountered in an expression

```

* / MOD SHL SHR
- +
NOT
AND
OR XOR

```

Thus, the expressions shown to the left below are interpreted by the assembler as the fully parenthesized expressions shown to the right below

a * b + c	(a * b) + c
a + b * c	a + (b * c)
a MOD b * c SHL d	((a MOD b) * c) SHL d

a OR b AND NOT c + d SHL e      a OR (b AND (NOT (c + (d SHL e))))

Balanced parenthesized subexpressions can always be used to override the assumed parentheses, and thus the last expression above could be rewritten to force application of operators in a different order as

(a OR b) AND (NOT c) + d SHL e

resulting in the assumed parentheses

(a OR b) AND ((NOT c) + (d SHL e))

Note that an unparenthesized expression is well-formed only if the expression which results from inserting the assumed parentheses is well-formed.

#### 4. ASSEMBLER DIRECTIVES.

Assembler directives are used to set labels to specific values during the assembly, perform conditional assembly, define storage areas, and specify starting addresses in the program. Each assembler directive is denoted by a "pseudo operation" which appears in the operation field of the line. The acceptable pseudo operations are

ORG	set the program or data origin
END	end program, optional start address
EQU	numeric "equate"
SET	numeric "set"
IF	begin conditional assembly
ENDIF	end of conditional assembly
DB	define data bytes
DW	define data words
DS	define data storage area

The individual pseudo operations are detailed below

##### 4.1. The ORG directive.

The ORG statement takes the form

label    ORG    expression

where "label" is an optional program label, and expression is a 16-bit expression, consisting of operands which are defined previous to the ORG statement. The assembler begins machine code generation at the location specified in the expression. There can be any number of ORG statements within a particular program, and there are no checks to ensure that the programmer is not defining overlapping memory areas. Note that most programs written for the CP/M system begin with an ORG statement of the form

ORG 100H

which causes machine code generation to begin at the base of the CP/M transient program area. If a label is specified in the ORG statement, then the label is given the value of the expression (this label can then be used in the operand field of other statements to represent this expression).

#### 4.2. The END directive.

The END statement is optional in an assembly language program, but if it is present it must be the last statement (all subsequent statements are ignored in the assembly). The two forms of the END directive are

```
label   END
label   END   expression
```

where the label is again optional. If the first form is used, the assembly process stops, and the default starting address of the program is taken as 0000. Otherwise, the expression is evaluated, and becomes the program starting address (this starting address is included in the last record of the Intel formatted machine code "hex" file which results from the assembly). Thus, most CP/M assembly language programs end with the statement

```
END 100H
```

resulting in the default starting address of 100H (beginning of the transient program area).

#### 4.3. The EQU directive.

The EQU (equate) statement is used to set up synonyms for particular numeric values. the form is

```
label   EQU   expression
```

where the label must be present, and must not label any other statement. The assembler evaluates the expression, and assigns this value to the identifier given in the label field. The identifier is usually a name which describes the value in a more human-oriented manner. Further, this name is used throughout the program to "parameterize" certain functions. Suppose for example, that data received from a Teletype appears on a particular input port, and data is sent to the Teletype through the next output port in sequence. The series of equate statements could be used to define these ports for a particular hardware environment

```
TTYBASE   EQU   10H      ;BASE PORT NUMBER FOR TTY
TTYIN     EQU   TTYBASE ;TTY DATA IN
TTYOUT    EQU   TTYBASE+1;TTY DATA OUT
```

At a later point in the program, the statements which access the Teletype could appear as

```

IN   TTYIN   ;READ TTY DATA TO REG-A
...
OUT  TTYOUT  ;WRITE DATA TO TTY FROM REG-A

```

making the program more readable than if the absolute i/o ports had been used. Further, if the hardware environment is redefined to start the Teletype communications ports at 7FH instead of 10H, the first statement need only be changed to

```

TTYBASE EQU 7FH ;BASE PORT NUMBER FOR TTY

```

and the program can be reassembled without changing any other statements.

#### 4.4. The SET Directive.

The SET statement is similar to the EQU, taking the form

```

label SET expression

```

except that the label can occur on other SET statements within the program. The expression is evaluated and becomes the current value associated with the label. Thus, the EQU statement defines a label with a single value, while the SET statement defines a value which is valid from the current SET statement to the point where the label occurs on the next SET statement. The use of the SET is similar to the EQU statement, but is used most often in controlling conditional assembly.

#### 4.5. The IF and ENDIF directives.

The IF and ENDIF statements define a range of assembly language statements which are to be included or excluded during the assembly process. The form is

```

IF expression
statement#1
statement#2
...
statement#n
ENDIF

```

Upon encountering the IF statement, the assembler evaluates the expression following the IF (all operands in the expression must be defined ahead of the IF statement). If the expression evaluates to a non-zero value, then statement#1 through statement#n are assembled; if the expression evaluates to zero, then the statements are listed but not assembled. Conditional assembly is often used to write a single "generic" program which includes a number of possible run-time environments, with only a few specific portions of the program selected for any particular assembly. The following program segments for example, might be part of a program which communicates with either a Teletype or a CRT console (but not both) by selecting a particular value for TTY before the assembly begins

```

TRUE    EQU    0FFFFH    ;DEFINE VALUE OF TRUE
FALSE   EQU    NOT TRUE  ;DEFINE VALUE OF FALSE
;
TTY     EQU    TRUE      ;TRUE IF TTY, FALSE IF CRT
;
TTYBASE EQU    10H       ;BASE OF TTY I/O PORTS
CRIBASE EQU    20H       ;BASE OF CRT I/O PORTS
        IF    TTY        ;ASSEMBLE RELATIVE TO TTYBASE
CONIN   EQU    TTYBASE   ;CONSOLE INPUT
CONOUT  EQU    TTYBASE+1 ;CONSOLE OUTPUT
        ENDIF
;
        IF    NOT TTY    ;ASSEMBLE RELATIVE TO CRIBASE
CONIN   EQU    CRIBASE   ;CONSOLE INPUT
CONOUT  EQU    CRIBASE+1 ;CONSOLE OUTPUT
        ENDIF
...
IN      CONIN           ;READ CONSOLE DATA
...
OUT     CONOUT          ;WRITE CONSOLE DATA

```

In this case, the program would assemble for an environment where a Teletype is connected, based at port 10H. The statement defining TTY could be changed to

```
TTY    EQU    FALSE
```

and, in this case, the program would assemble for a CRT based at port 20H.

#### 4.6. The DB Directive.

The DB directive allows the programmer to define initialize storage areas in single precision (byte) format. The statement form is

```
label  DB    e#1, e#2, ..., e#n
```

where e#1 through e#n are either expressions which evaluate to 8-bit values (the high order eight bits must be zero), or are ASCII strings of length no greater than 64 characters. There is no practical restriction on the number of expressions included on a single source line. The expressions are evaluated and placed sequentially into the machine code file following the last program address generated by the assembler. String characters are similarly placed into memory starting with the first character and ending with the last character. Strings of length greater than two characters cannot be used as operands in more complicated expressions (i.e., they must stand alone between the commas). Note that ASCII characters are always placed in memory with the parity bit reset (0). Further, recall that there is no translation from lower to upper case within strings. The optional label can be used to reference the data area throughout the remainder of the program. Examples of

valid DB statements are

```
data:  DB  0,1,2,3,4,5
        DB  data and 0ffh,5,3770,1+2+3+4
signon: DB  'please type your name',cr,lf,0
        DB  'AB' SHR 8, 'C', 'DE' AND 7FH
```

#### 4.7. The DW Directive.

The DW statement is similar to the DB statement except double precision (two byte) words of storage are initialized. The form is

```
label  DW  e#1, e#2, ..., e#n
```

where e#1 through e#n are expressions which evaluate to 16-bit results. Note that ASCII strings of length one or two characters are allowed, but strings longer than two characters disallowed. In all cases, the data storage is consistent with the 8080 processor: the least significant byte of the expression is stored first in memory, followed by the most significant byte. Examples are

```
doub:  DW  0ffefh,doub+4,signon-$,255+255
        DW  'a', 5, 'ab', 'CD', 6 shl 8 or 11b
```

#### 4.8. The DS Directive.

The DS statement is used to reserve an area of uninitialized memory, and takes the form

```
label  DS  expression
```

where the label is optional. The assembler begins subsequent code generation after the area reserved by the DS. Thus, the DS statement given above has exactly the same effect as the statement

```
label: EQU $ ;LABEL VALUE IS CURRENT CODE LOCATION
        ORG $+expression ;MOVE PAST RESERVED AREA
```

### 5. OPERATION CODES.

Assembly language operation codes form the principal part of assembly language programs, and form the operation field of the instruction. In general, ASM accepts all the standard mnemonics for the Intel 8080 microcomputer, which are given in detail in the Intel manual "8080 Assembly Language Programming Manual." Labels are optional on each input line and, if included, take the value of the instruction address immediately before the instruction is issued. The individual operators are listed briefly in the

following sections for completeness, although it is understood that the Intel manuals should be referenced for exact operator details. In each case,

- e3 represents a 3-bit value in the range 0-7 which can be one of the predefined registers A, B, C, D, E, H, L, M, SP, or PSW.
- e8 represents an 8-bit value in the range 0-255
- e16 represents a 16-bit value in the range 0-65535

which can themselves be formed from an arbitrary combination of operands and operators. In some cases, the operands are restricted to particular values within the allowable range, such as the PUSH instruction. These cases will be noted as they are encountered.

In the sections which follow, each operation codes is listed in its most general form, along with a specific example, with a short explanation and special restrictions.

### 5.1. Jumps, Calls, and Returns.

The Jump, Call, and Return instructions allow several different forms which test the condition flags set in the 8080 microcomputer CPU. The forms are

JMP	e16	JMP	L1	Jump unconditionally to label
JNZ	e16	JMP	L2	Jump on non zero condition to label
JZ	e16	JMP	100H	Jump on zero condition to label
JNC	e16	JNC	L1+4	Jump no carry to label
JC	e16	JC	L3	Jump on carry to label
JPO	e16	JPO	\$+8	Jump on parity odd to label
JPE	e16	JPE	L4	Jump on even parity to label
JP	e16	JP	GAMMA	Jump on positive result to label
JM	e16	JM	a1	Jump on minus to label
CALL	e16	CALL	S1	Call subroutine unconditionally
CNZ	e16	CNZ	S2	Call subroutine if non zero flag
CZ	e16	CZ	100H	Call subroutine on zero flag
CNC	e16	CNC	S1+4	Call subroutine if no carry set
CC	e16	CC	S3	Call subroutine if carry set
CPO	e16	CPO	\$+8	Call subroutine if parity odd
CPE	e16	CPE	S4	Call subroutine if parity even
CP	e16	CP	GAMMA	Call subroutine if positive result
CM	e16	CM	b1\$c2	Call subroutine if minus flag
RST	e3	RST	0	Programmed "restart", equivalent to CALL 8*e3, except one byte call

RET	Return from subroutine
RNZ	Return if non zero flag set
RZ	Return if zero flag set
RNC	Return if no carry
RC	Return if carry flag set
RPO	Return if parity is odd
RPE	Return if parity is even
RP	Return if positive result
RM	Return if minus flag is set

## 5.2. Immediate Operand Instructions.

Several instructions are available which load single or double precision registers, or single precision memory cells, with constant values, along with instructions which perform immediate arithmetic or logical operations on the accumulator (register A).

MVI e3,e8	MVI B,255	Move immediate data to register A, B, C, D, E, H, L, or M (memory)
ADI e8	ADI 1	Add immediate operand to A without carry
ACI e8	ACI 0FFH	Add immediate operand to A with carry
SUI e8	SUI L + 3	Subtract from A without borrow (carry)
SBI e8	SBI L AND 11B	Subtract from A with borrow (carry)
ANI e8	ANI \$ AND 7FH	Logical "and" A with immediate data
XRI e8	XRI 1111\$0000B	"Exclusive or" A with immediate data
ORI e8	ORI L AND l+l	Logical "or" A with immediate data
CPI e8	CPI 'a'	Compare A with immediate data (same as SUI except register A not changed)
LXI e3,e16	LXI B,100H	Load extended immediate to register pair (e3 must be equivalent to B,D,H, or SP)

## 5.3. Increment and Decrement Instructions.

Instructions are provided in the 8080 repertoire for incrementing or decrementing single and double precision registers. The instructions are

INR e3	INR E	Single precision increment register (e3 produces one of A, B, C, D, E, H, L, M)
DCR e3	DCR A	Single precision decrement register (e3 produces one of A, B, C, D, E, H, L, M)
INX e3	INX SP	Double precision increment register pair (e3 must be equivalent to B,D,H, or SP)
DCX e3	DCX B	Double precision decrement register pair (e3 must be equivalent to B,D,H, or SP)

## 5.4. Data Movement Instructions.



Instructions which move data from memory to the CPU and from CPU to memory are given below

MOV e3,e3	MOV A,B	Move data to leftmost element from rightmost element (e3 produces one of A,B,C D,E,H,L, or M). MOV M,M is disallowed
LDAX e3	LDAX B	Load register A from computed address (e3 must produce either B or D)
STAX e3	STAX D	Store register A to computed address (e3 must produce either B or D)
LHLD e16	LHLD L1	Load HL direct from location e16 (double precision load to H and L)
SHLD e16	SHLD L5+x	Store HL direct to location e16 (double precision store from H and L to memory)
LDA e16	LDA Gamma	Load register A from address e16
STA e16	STA X3-5	Store register A into memory at e16
POP e3	POP PSW	Load register pair from stack, set SP (e3 must produce one of B, D, H, or PSW)
PUSH e3	PUSH B	Store register pair into stack, set SP (e3 must produce one of B, D, H, or PSW)
IN e8	IN 0	Load register A with data from port e8
OUT e8	OUT 255	Send data from register A to port e8
XTHL		Exchange data from top of stack with HL
PCHL		Fill program counter with data from HL
SPHL		Fill stack pointer with data from HL
XCHG		Exchange DE pair with HL pair

### 5.5. Arithmetic Logic Unit Operations.

Instructions which act upon the single precision accumulator to perform arithmetic and logic operations are

ADD e3	ADD B	Add register given by e3 to accumulator without carry (e3 must produce one of A, B, C, D, E, H, or L)
ADC e3	ADC L	Add register to A with carry, e3 as above
SUB e3	SUB H	Subtract reg e3 from A without carry, e3 is defined as above
SBB e3	SBB 2	Subtract register e3 from A with carry, e3 defined as above
ANA e3	ANA 1+1	Logical "and" reg with A, e3 as above
XRA e3	XRA A	"Exclusive or" with A, e3 as above
ORA e3	ORA B	Logical "or" with A, e3 defined as above
CMP e3	CMP H	Compare register with A, e3 as above
DAA		Decimal adjust register A based upon last arithmetic logic unit operation
CMA		Complement the bits in register A
STC		Set the carry flag to 1

CMC		Complement the carry flag
RLC		Rotate bits left, (re)set carry as a side effect (high order A bit becomes carry)
RRC		Rotate bits right, (re)set carry as side effect (low order A bit becomes carry)
RAL		Rotate carry/A register to left (carry is involved in the rotate)
RAR		Rotate carry/A register to right (carry is involved in the rotate)
DAD e3	DAD B	Double precision add register pair e3 to HL (e3 must produce B, D, H, or SP)

### 5.6. Control Instructions.

The four remaining instructions are categorized as control instructions, and are listed below

HLT	Halt the 8080 processor
DI	Disable the interrupt system
EI	Enable the interrupt system
NOP	No operation

### 6. ERROR MESSAGES.

When errors occur within the assembly language program, they are listed as single character flags in the leftmost position of the source listing. The line in error is also echoed at the console so that the source listing need not be examined to determine if errors are present. The error codes are

D	Data error: element in data statement cannot be placed in the specified data area
E	Expression error: expression is ill-formed and cannot be computed at assembly time
L	Label error: label cannot appear in this context (may be duplicate label)
N	Not implemented: features which will appear in future ASM versions (e.g., macros) are recognized, but flagged in this version)
O	Overflow: expression is too complicated (i.e., too many pending operators) to computed, simplify it
P	Phase error: label does not have the same value on two subsequent passes through the program

- R Register error: the value specified as a register is not compatible with the operation code
- V Value error: operand encountered in expression is improperly formed

Several error message are printed which are due to terminal error conditions

- NO SOURCE FILE PRESENT The file specified in the ASM command does not exist on disk
- NO DIRECTORY SPACE The disk directory is full, erase files which are not needed, and retry
- SOURCE FILE NAME ERROR Improperly formed ASM file name (e.g., it is specified with "?" fields)
- SOURCE FILE READ ERROR Source file cannot be read properly by the assembler, execute a TYPE to determine the point of error
- OUTPUT FILE WRITE ERROR Output files cannot be written properly, most likely cause is a full disk, erase and retry
- CANNOT CLOSE FILE Output file cannot be closed, check to see if disk is write protected

## 7. A SAMPLE SESSION.

The following session shows interaction with the assembler and debugger in the development of a simple assembly language program.

ASM SORT, assemble SORT.ASM

CP/M ASSEMBLER - VER 1.0

015C *next free address*  
003H USE FACTOR % of table used 00 TO FF (hexadecimal)  
END OF ASSEMBLY

DIR SORT.\*

SORT ASM *source file*  
SORT BAK *backup from last edit*  
SORT PRN *print file (contains tab characters)*  
SORT HEX *machine code file*  
A>TYPE SORT.PRN

*Source line*

*machine code location* ;  
0100 *generated machine code* ; SORT PROGRAM IN CP/M ASSEMBLY LANGUAGE  
START AT THE BEGINNING OF THE TRANSIENT PROGRAM AR  
ORG 100H  
0100 214601 SORT: LXI H, SW ; ADDRESS SWITCH TOGGLE  
0103 3601 MVI M, 1 ; SET TO 1 FOR FIRST ITERATION  
0105 214701 LXI H, I ; ADDRESS INDEX  
0108 3600 MVI M, 0 ; I = 0  
; ;  
; COMPARE I WITH ARRAY SIZE  
010A 7E COMP: MOV A, M ; A REGISTER = I  
010B FE09 CPI N-1 ; CY SET IF I < (N-1)  
010D D21901 JNC CONT ; CONTINUE IF I <= (N-2)  
; ;  
; END OF ONE PASS THROUGH DATA  
0110 214601 LXI H, SW ; CHECK FOR ZERO SWITCHES  
0113 7EB7C20001 MOV A, M! ORA A! JNZ SORT ; END OF SORT IF SW=0  
; ;  
0118 FF RST 7 ; GO TO THE DEBUGGER INSTEAD OF REP  
; ;  
; *truncated* CONTINUE THIS PASS  
; ADDRESSING I, SO LOAD AV(I) INTO REGISTERS  
0119 5F16002148CONT: MOV E, A! MVI D, 0! LXI H, AV! DAD D! DAD D  
0121 4E792346 MOV C, M! MOV A, C! INX H! MOV B, M  
; LDW ORDER BYTE IN A AND C, HIGH ORDER BYTE IN B  
; ;  
; MOV H AND L TO ADDRESS AV(I+1)  
0125 23 INX H  
; ;  
; COMPARE VALUE WITH REGS CONTAINING AV(I)  
0126 965778239E SUB M! MOV D, A! MOV A, B! INX H! SBB M ; SUBTRACT  
; ;  
; BORROW SET IF AV(I+1) > AV(I)  
0128 DA3F01 JC INCI ; SKIP IF IN PROPER ORDER  
; ;  
; CHECK FOR EQUAL VALUES  
012E B2CA3F01 ORA D! JZ INCI ; SKIP IF AV(I) = AV(I+1)

```

0132 56702B5E      MOV D,M! MOV M,B! DCX H! MOV E,M
0136 712B722B73    MOV M,C! DCX HI MOV M,D! DCX H! MOV M,E
;
;
;      INCREMENT SWITCH COUNT
013B 21460134      LXI H,SU! INR M
;
;
;      INCREMENT I
013F 21470134C3INCI LXI H,I! INR M! JMP CMP
;
;      DATA DEFINITION SECTION
0146 00           SU:  DB      0           ;RESERVE SPACE FOR SWITCH COUNT
0147             I:   DS      1           ;SPACE FOR INDEX
0148 050064001EAV: DW      5,100,30,50,20,7,1000,300,100,-32767
000A = equate value N EQU      ($-AV)/2           ;COMPUTE N INSTEAD OF PRE
015C             END

```

A>TYPE SORT.HEX

```

:10010000214601360121470136007EFE09D2190140
:100110002146017EB7C20001FF5F16002148011900
:10012000194E79234623965778239EDA3F01B2CAA7
:100130003F0156702B5E712B722B732146013421C7
:07014000470134C30A01006E
:10014000050064001E00320014000700E0032C01BB
:0401500064000180BE
:0000000000

```

machine code in HEX format

A>DDT SORT.HEX start debug run

16K DDT VER 1.0  
NEXT PC  
015C 0000 default address (no address on END statement)  
-XP

P=0000 100, change PC to 100  
-UFFFF, untrace for 65535 steps

abort with reubout

C0Z0M0E010 A=00 B=0000 D=0000 H=0000 S=0100 P=0100 LXI H,0146\*0100  
-T10, trace 10 steps

```

C0Z0M0E010 A=01 B=0000 D=0000 H=0146 S=0100 P=0100 LXI H,0146
C0Z0M0E010 A=01 B=0000 D=0000 H=0146 S=0100 P=0103 MVI M,01
C0Z0M0E010 A=01 B=0000 D=0000 H=0146 S=0100 P=0105 LXI H,0147
C0Z0M0E010 A=01 B=0000 D=0000 H=0147 S=0100 P=0108 MVI M,00
C0Z0M0E010 A=01 B=0000 D=0000 H=0147 S=0100 P=010A MOV A,M
C0Z0M0E010 A=00 B=0000 D=0000 H=0147 S=0100 P=010B CPI 09
C1Z0M1E010 A=00 B=0000 D=0000 H=0147 S=0100 P=010D JNC 0119
C1Z0M1E010 A=00 B=0000 D=0000 H=0147 S=0100 P=0110 LXI H,0146
C1Z0M1E010 A=00 B=0000 D=0000 H=0146 S=0100 P=0113 MOV A,M
C1Z0M1E010 A=01 B=0000 D=0000 H=0146 S=0100 P=0114 ORA A
C0Z0M0E010 A=01 B=0000 D=0000 H=0146 S=0100 P=0115 JNZ 0100
C0Z0M0E010 A=01 B=0000 D=0000 H=0146 S=0100 P=0100 LXI H,0146
C0Z0M0E010 A=01 B=0000 D=0000 H=0146 S=0100 P=0103 MVI M,01
C0Z0M0E010 A=01 B=0000 D=0000 H=0146 S=0100 P=0105 LXI H,0147
C0Z0M0E010 A=01 B=0000 D=0000 H=0147 S=0100 P=0108 MVI M,00
C0Z0M0E010 A=01 B=0000 D=0000 H=0147 S=0100 P=010A MOV A,M*010B
-A10D

```

010D JC 119, change to a jump on carry  
0110

stopped at 10BH

-XP<sub>2</sub>

P=0100 100, reset program counter back to beginning of program

-T10, trace execution for 10H steps

```

C0Z0M0E0I0 A=00 B=0000 D=0000 H=0147 S=0100 P=0100 LXI H,0146
C0Z0M0E0I0 A=00 B=0000 D=0000 H=0146 S=0100 P=0103 MVI M,01
C0Z0M0E0I0 A=00 B=0000 D=0000 H=0146 S=0100 P=0105 LXI H,0147
C0Z0M0E0I0 A=00 B=0000 D=0000 H=0147 S=0100 P=0108 MVI M,00
C0Z0M0E0I0 A=00 B=0000 D=0000 H=0147 S=0100 P=010A MOV A,M
C0Z0M0E0I0 A=00 B=0000 D=0000 H=0147 S=0100 P=010B CPI 09
C1Z0M1E0I0 A=00 B=0000 D=0000 H=0147 S=0100 P=010D JC 0119
C1Z0M1E0I0 A=00 B=0000 D=0000 H=0147 S=0100 P=0119 MOV E,A
C1Z0M1E0I0 A=00 B=0000 D=0000 H=0147 S=0100 P=011A MVI D,00
C1Z0M1E0I0 A=00 B=0000 D=0000 H=0147 S=0100 P=011C LXI H,0148
C1Z0M1E0I0 A=00 B=0000 D=0000 H=0148 S=0100 P=011F DAD D
C0Z0M1E0I0 A=00 B=0000 D=0000 H=0148 S=0100 P=0120 DAD D
C0Z0M1E0I0 A=00 B=0000 D=0000 H=0148 S=0100 P=0121 MOV C,M
C0Z0M1E0I0 A=00 B=0005 D=0000 H=0148 S=0100 P=0122 MOV A,C
C0Z0M1E0I0 A=05 B=0005 D=0000 H=0148 S=0100 P=0123 INX H
C0Z0M1E0I0 A=05 B=0005 D=0000 H=0149 S=0100 P=0124 MOV B,M=0125

```

Altered instruction

-L100<sub>2</sub>

```

0100 LXI H,0146
0103 MVI M,01
0105 LXI H,0147
0108 MVI M,00
010A MOV A,M
010B CPI 09
010D JC 0119
0110 LXI H,0146
0113 MOV A,M
0114 ORA A
0115 JNZ 0100

```

list some code from 100H

Automatic breakpoint

-L<sub>2</sub>

```

0118 RST 07
0119 MOV E,A
011A MVI D,00
011C LXI H,0148

```

list more

- About list with rubart

-G.118, start program from current PC (0125H) and run in real time to 11BH

\*0127 stopped with an external interrupt 7 from front panel (program was looping indefinitely)

-T<sup>4</sup><sub>2</sub> look at looping program in trace mode

```

C0Z0M0E0I0 A=38 B=0064 D=0006 H=0156 S=0100 P=0127 MOV D,A
C0Z0M0E0I0 A=38 B=0064 D=3806 H=0156 S=0100 P=0128 MOV A,B
C0Z0M0E0I0 A=00 B=0064 D=3806 H=0156 S=0100 P=0129 INX H
C0Z0M0E0I0 A=00 B=0064 D=3806 H=0157 S=0100 P=012A SBB M=012B

```

-D148

```

0148 05 00 07 00 14 00 1E 00 .....
0150 32 00 64 00 64 00 2C 01 E8 03 01 80 00 00 00 00 00 2.D.D.....
0160 00 00 00 00 00 00 00 00 00 00 00 00 00 00 00 00 .....

```

data is sorted, but program doesn't stop.

-G, return to CP/M

DDT SORT.HEX, reload the memory image

16K DDT VER 1.0  
NEXT PC  
015C 0000  
-XP

P=0000 100, set PC to beginning of program

-L100, list bad opcode

0100 JNC 0119 ✓  
0110 LXI H,0146

- abort list with r/bout

-A100, assemble new opcode

0100 JC 119,

0110,

-L100, list starting section of program

0100 LXI H,0146  
0103 MVI M,01  
0105 LXI H,0147  
0108 MVI M,00

- abort list with r/bout

-A103, change "switch" initialization to 00

0103 MVI M,0,

0105,

-c return to CP/M with ct/c (G works as well)

SAVE 1 SORT.COM, save 1 page (256 bytes, from 100H to 1FFH) on disk in case we have to reload later

A>DDT SORT.COM, restart DDT with saved memory image

16K DDT VER 1.0  
NEXT PC

0200 0100 "COM" file always starts with address 100H

-G, run the program from PC=100H

\*0110 programmed stop (RST7) encountered  
-D148

← data properly sorted

0148 05 00 07 00 14 00 1E 00 .....  
0150 32 00 64 00 64 00 2C 01 E8 03 01 80 00 00 00 00 2.D.D.....  
0160 00 00 00 00 00 00 00 00 00 00 00 00 00 00 00 00 .....  
0170 00 00 00 00 00 00 00 00 00 00 00 00 00 00 00 00 .....

-G, return to CP/M

ED SORT.ASM, make changes to original program

```

* N. 0^Z0TT, find next ";"
  MVI    M, 0      ; I = 0
*-> up one line in text
  LXI    H, I      ; ADDRESS INDEX
*-> up another line
  MVI    M, 1      ; SET TO 1 FOR FIRST ITERATION
* K, kill line and type next line
  LXI    H, I      ; ADDRESS INDEX
* I, insert new line
  MVI    M, 0      ; ZERO SW
* T,
  LXI    H, I      ; ADDRESS INDEX
* NJNC^Z0T,
  JNC *T,
  CONT   ; CONTINUE IF I <= (N-2)
*- 2D IC^Z0LT,
  JC     CONT      ; CONTINUE IF I <= (N-2)
* E,
  source from disk A
  here to disk A
  skip prn file
ASM SORT.AAZ

```

CP/M ASSEMBLER - VER 1.0

015C next address to assemble  
003H USE FACTOR  
END OF ASSEMBLY

DDT SORT.HEX, test program changes

```

16K DDT VER 1.0
NEXT PC
015C 0000
-G100,

+0110
-D140,

0140 05 00 07 00 14 00 1E 00 ..... data sorted
0150 32 00 64 00 64 00 2C 01 E8 03 01 00 00 00 00 00 2 D D .....
0160 00 00 00 00 00 00 00 00 00 00 00 00 00 00 00 .....

```

- abort with rubout  
-G0, return to CP/M - program checks OK.



**ED: A CONTEXT EDITOR FOR THE CP/M DISK SYSTEM: USER'S MANUAL**

## COPYRIGHT

Copyright (c) 1980 by Exidy Systems, Inc. All rights reserved. No part of this publication may be reproduced, transmitted, transcribed, stored in a retrieval system, or translated into any language, in any form or by any means, electronic, mechanical, magnetic, optical, chemical, manual, or otherwise, without the prior written permission of Exidy Systems, Inc., 1234 Elko Drive, Sunnyvale, California 94086.

Since this manual is tutorial in nature, permission is granted to reproduce or abstract the example procedures and sample programs for the purposes of inclusion within the reader's programs.

## DISCLAIMER

Exidy Systems, Inc. makes no representations or warranties with respect to the contents hereof and specifically disclaims any implied warranties of merchantability or fitness for any particular purpose. Further, Exidy Systems, Inc. reserves the right to revise this publication and to make changes from time to time in the content hereof without obligation of Exidy Systems, Inc. to notify any person of such revision or changes.

## TRADEMARKS

CP/M is a registered trademark of Digital Research.

**ED: A CONTEXT EDITOR FOR THE CP/M DISK SYSTEM: USER'S MANUAL**

## COPYRIGHT

Copyright (c) 1980 by Exidy Systems, Inc. All rights reserved. No part of this publication may be reproduced, transmitted, transcribed, stored in a retrieval system, or translated into any language, in any form or by any means, electronic, mechanical, magnetic, optical, chemical, manual, or otherwise, without the prior written permission of Exidy Systems, Inc., 1234 Elko Drive, Sunnyvale, California 94086.

Since this manual is tutorial in nature, permission is granted to reproduce or abstract the example procedures and sample programs for the purposes of inclusion within the reader's programs.

## DISCLAIMER

Exidy Systems, Inc. makes no representations or warranties with respect to the contents hereof and specifically disclaims any implied warranties of merchantability or fitness for any particular purpose. Further, Exidy Systems, Inc. reserves the right to revise this publication and to make changes from time to time in the content hereof without obligation of Exidy Systems, Inc. to notify any person of such revision or changes.

## TRADEMARKS

CP/M is a registered trademark of Digital Research.

## Table Of Contents

### ED: A Content Editor For The CP/M Disk System: User's Manual

1.	ED Tutorial.....	93
	1.1 Introduction to ED.....	93
	1.2 ED Operation.....	93
	1.3 Text Transfer Functions.....	93
	1.4 Memory Buffer Organization.....	97
	1.5 Memory Buffer Operation.....	97
	1.6 Command Srrings.....	99
	1.7 Text Search and Alteration.....	100
	1.8 Source Libraries.....	103
	1.9 Repetitive Command Execution.....	104
2.	ED Error Conditions.....	105
3.	Control Characters And Commands.....	106



## ED USER'S MANUAL

### 1. ED TUTORIAL

#### 1.1. Introduction to ED.

ED is the context editor for CP/M, and is used to create and alter CP/M source files. ED is initiated in CP/M by typing

$$\text{ED} \left\{ \begin{array}{l} \langle \text{filename} \rangle \\ \langle \text{filename} \rangle . \langle \text{filetype} \rangle \end{array} \right\}$$

In general, ED reads segments of the source file given by `<filename>` or `<filename> . <filetype>` into central memory, where the file is manipulated by the operator, and subsequently written back to disk after alterations. If the source file does not exist before editing, it is created by ED and initialized to empty. The overall operation of ED is shown in Figure 1.

#### 1.2. ED Operation

ED operates upon the source file, denoted in Figure 1 by `x.y`, and passes all text through a memory buffer where the text can be viewed or altered (the number of lines which can be maintained in the memory buffer varies with the line length, but has a total capacity of about 6000 characters in a 16K CP/M system). Text material which has been edited is written onto a temporary work file under command of the operator. Upon termination of the edit, the memory buffer is written to the temporary file, followed by any remaining (unread) text in the source file. The name of the original file is changed from `x.y` to `x.BAK` so that the most recent previously edited source file can be reclaimed if necessary (see the CP/M commands ERASE and RENAME). The temporary file is then changed from `x.$$$` to `x.y` which becomes the resulting edited file.

The memory buffer is logically between the source file and working file as shown in Figure 2.

#### 1.3. Text Transfer Functions

Given that `n` is an integer value in the range 0 through 65535, the following ED commands transfer lines of text from the source file through the memory buffer to the temporary (and eventually final) file:

Figure 1. Overall ED Operation

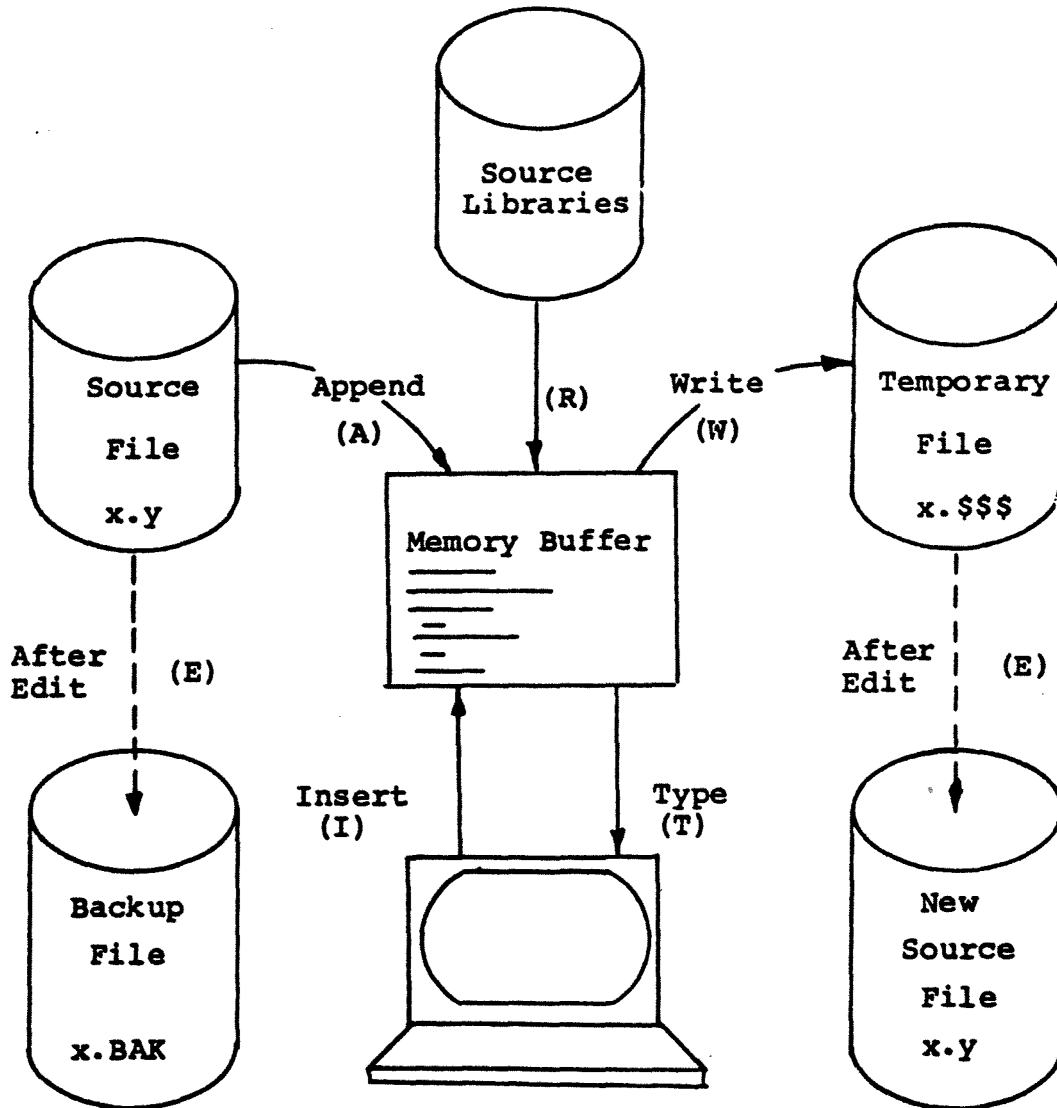

Note: the ED program accepts both lower and upper case ASCII characters as input from the console. Single letter commands can be typed in either case. The U command can be issued to cause ED to translate lower case alphabetic characters to upper case as characters are filled to the memory buffer from the console. Characters are echoed as typed without translation, however. The -U command causes ED to revert to "no translation" mode. ED starts with an assumed -U in effect.



Figure 2. Memory Buffer Organization

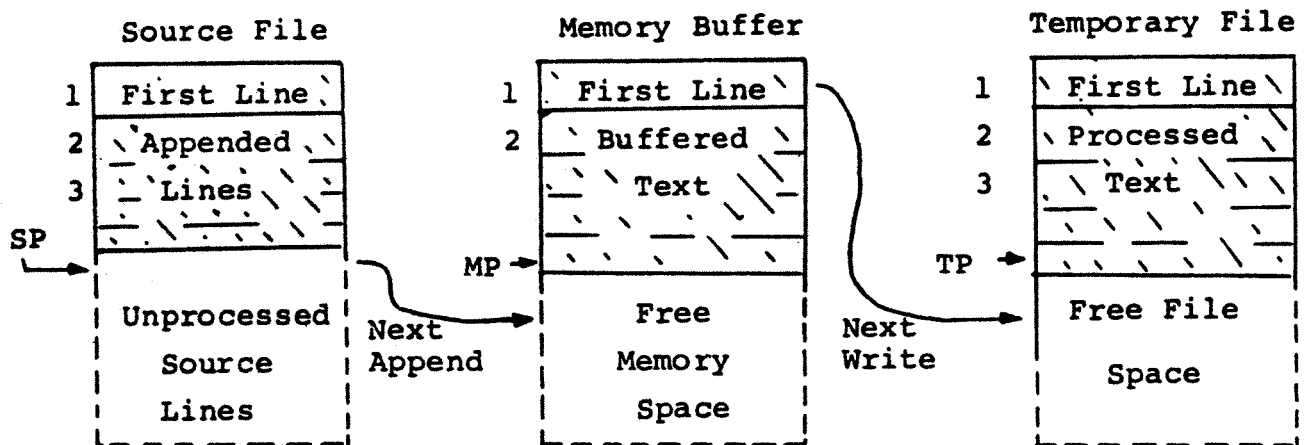
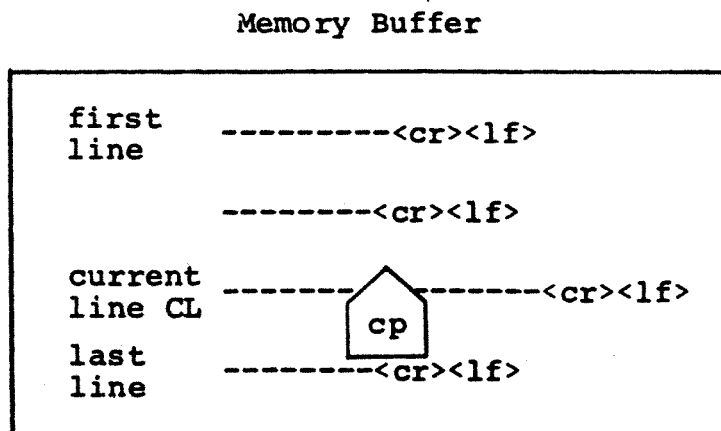

Figure 3. Logical Organization of Memory Buffer



- nA<cr>\* - append the next n unprocessed source lines from the source file at SP to the end of the memory buffer at MP. Increment SP and MP by n.
  
- nW<cr> - write the first n lines of the memory buffer to the temporary file free space. Shift the remaining lines n+1 through MP to the top of the memory buffer. Increment TP by n.
  
- E<cr> - end the edit. Copy all buffered text to temporary file, and copy all unprocessed source lines to the temporary file. Rename files as described previously.
  
- H<cr> - move to head of new file by performing automatic E command. Temporary file becomes the new source file, the memory buffer is emptied, and a new temporary file is created (equivalent to issuing an E command, followed by a reinvocation of ED using x.y as the file to edit).
  
- O<cr> - return to original file. The memory buffer is emptied, the temporary file id deleted, and the SP is returned to position 1 of the source file. The effects of the previous editing commands are thus nullified.
  
- Q<cr> - quit edit with no file alterations, return to CP/M.

There are a number of special cases to consider. If the integer n is omitted in any ED command where an integer is allowed, then 1 is assumed. Thus, the commands A and W append one line and write 1 line, respectively. In addition, if a pound sign (#) is given in the place of n, then the integer 65535 is assumed (the largest value for n which is allowed). Since most reasonably sized source files can be contained entirely in the memory buffer, the command #A is often issued at the beginning of the edit to read the entire source file to memory. Similarly, the command #W writes the entire buffer to the temporary file. Two special forms of the A and W

---

\*<cr> represents the carriage-return key

commands are provided as a convenience. The command 0A fills the current memory buffer to at least half-full, while 0W writes lines until the buffer is at least half empty. It should also be noted that an error is issued if the memory buffer size is exceeded. The operator may then enter any command (such as W) which does not increase memory requirements. The remainder of any partial line read during the overflow will be brought into memory on the next successful append.

#### 1.4. Memory Buffer Organization

The memory buffer can be considered a sequence of source lines brought in with the A command from a source file. The memory buffer has an associated (imaginary) character pointer CP which moves throughout the memory buffer under command of the operator. The memory buffer appears logically as shown in Figure 3 where the dashes represent characters of the source line of indefinite length, terminated by carriage-return (<cr>) and line-feed (<lf>) characters, and  represents the imaginary character pointer. Note that the CP is always located ahead of the first character of the first line, behind the last character of the last line, or between two characters. The current line CL is the source line which contains the CP.

#### 1.5. Memory Buffer Operation

Upon initiation of ED, the memory buffer is empty (ie, CP is both ahead and behind the first and last character). The operator may either append lines (A command) from the source file, or enter the lines directly from the console with the insert command

I<cr>

ED then accepts any number of input lines, where each line terminates with a <cr> (the <lf> is supplied automatically), until a control-z (denoted by †z is typed by the operator. The CP is positioned after the last character entered. The sequence

```
I<cr>
NOW IS THE<cr>
TIME FOR<cr>
ALL GOOD MEN<cr>
†z
```

leaves the memory buffer as shown below

NOW IS THE<cr><lf>  
TIME FOR<cr><lf>  
ALL GOOD MEN<cr><lf>



Various commands can then be issued which manipulate the CP or display source text in the vicinity of the CP. The commands shown below with a preceding n indicate that an optional unsigned value can be specified. When preceded by ±, the command can be unsigned, or have an optional preceding plus or minus sign. As before, the pound sign (#) is replaced by 65535. If an integer n is optional, but not supplied, then n=1 is assumed. Finally, if a plus sign is optional, but none is specified, then + is assumed.

- ±B<cr> - move CP to beginning of memory buffer if +, and to bottom if -.
- ±nC<cr> - move CP by ±n characters (toward front of buffer if +), counting the <cr><lf> as two distinct characters
- ±nD<cr> - delete n characters ahead of CP if plus and behind CP if minus.
- ±nK<cr> - kill (ie remove) ±n lines of source text using CP as the current reference. If CP is not at the beginning of the current line when K is issued, then the characters before CP remain if + is specified, while the characters after CP remain if - is given in the command.
- ±nL<cr> - if n=0 then move CP to the beginning of the current line (if it is not already there) if n≠0 then first move the CP to the beginning of the current line, and then move it to the beginning of the line which is n lines down (if +) or up (if -). The CP will stop at the top or bottom of the memory buffer if too large a value of n is specified.

`+nT<cr>` - If `n=0` then type the contents of the current line up to CP. If `n=1` then type the contents of the current line from CP to the end of the line. If `n>1` then type the current line along with `n-1` lines which follow, if `+` is specified. Similarly, if `n>1` and `-` is given, type the previous `n` lines, up to the CP. The break key can be depressed to abort long type-outs.



`+n<cr>` - equivalent to `+nLT`, which moves up or down and types a single line

### 1.6. Command Strings

Any number of commands can be typed contiguously (up to the capacity of the CP/M console buffer), and are executed only after the `<cr>` is typed. Thus, the operator may use the CP/M console command functions to manipulate the input command:

Rubout	remove the last character
Control-U	delete the entire line
Control-C	re-initialize the CP/M System
Control-E	return carriage for long lines without transmitting buffer (max 128 chars)

Suppose the memory buffer contains the characters shown in the previous section, with the CP following the last character of the buffer. The command strings shown below produce the results shown to the right

<u>Command String</u>	<u>Effect</u>	<u>Resulting Memory Buffer</u>
1. B2T<cr>	move to beginning of buffer and type 2 lines: "NOW IS THE TIME FOR"	 NOW IS THE<cr><lf> TIME FOR<cr><lf> ALL GOOD MEN<cr><lf>
2. 5C0T<cr>	move CP 5 characters and type the beginning of the line "NOW I"	NOW I  S THE<cr><lf>

- |    |  |   |  |
|----|--|---|--|
| 3. | 2L-T<cr>                                 | move two lines down<br>and type previous<br>line<br>"TIME FOR"            | NOW IS THE<cr><lf><br>TIME FOR<cr><lf><br>ALL GOOD MEN<cr><lf> |
|    |  |   | cp   |
| 4. | -L#K<cr>                                 | move up one line,<br>delete 65535 lines<br>which follow                   | NOW IS THE<cr><lf>   |
|    |  |   | cp   |
| 5. | I<cr><br>TIME TO<cr><br>INSERT<cr><br>↑z | insert two lines<br>of text   | NOW IS THE<cr><lf><br>TIME TO<cr><lf><br>INSERT<cr><lf>        |
|    |  |   | cp   |
| 6. | -2L#T<cr>                                | move up two lines,<br>and type 65535<br>lines ahead of CP<br>"NOW IS THE" | NOW IS THE<cr><lf><br>TIME TO<cr><lf><br>INSERT<cr><lf>        |
|    |  |   | cp   |
| 7. | <cr>                                     | move down one line<br>and type one line<br>"INSERT"                       | NOW IS THE<cr><lf><br>TIME TO<cr><lf><br>INSERT<cr><lf>        |
|    |  |   | cp   |

### 1.7. Text Search and Alteration

ED also has a command which locates strings within the memory buffer. The command takes the form



$$nF c_1 c_2 \dots c_k \left\{ \begin{array}{l} \langle cr \rangle \\ \uparrow z \end{array} \right\}$$

where  $c_1$  through  $c_k$  represent the characters to match followed by either a <cr> or control -z\*. ED starts at the current position of CP and attempts to match all k characters. The match is attempted n times, and if successful, the CP is moved directly after the character  $c_k$ . If the n matches are not successful, the CP is not moved from its initial position. Search strings can include ↑l (control-l), which is replaced by the pair of symbols <cr><lf>.

---

\*The control-z is used if additional commands will be typed following the ↑z.

The following commands illustrate the use of the F command:

<u>Command String</u>	<u>Effect</u>	<u>Resulting Memory Buffer</u>
1. B#T<cr>	move to beginning and type entire buffer	 NOW IS THE<cr><lf> TIME FOR<cr><lf> ALL GOOD MEN<cr><lf>
2. FS T<cr>	find the end of the string "S T"	NOW IS T  HE<cr><lf>
3. FI↑zOTT	find the next "I" and type to the CP then type the remainder of the current line: "TIME FOR"	NOW IS THE<cr><lf> TI  ME FOR<cr><lf> ALL GOOD MEN<cr><lf>

An abbreviated form of the insert command is also allowed, which is often used in conjunction with the F command to make simple textual changes. The form is:

I c<sub>1</sub>c<sub>2</sub>... c<sub>n</sub>↑z or

I c<sub>1</sub>c<sub>2</sub>... c<sub>n</sub><cr>

where c<sub>1</sub> through c<sub>n</sub> are characters to insert. If the insertion string is terminated by a ↑z, the characters c<sub>1</sub> through c<sub>n</sub> are inserted directly following the CP, and the CP is moved directly after character c<sub>n</sub>. The action is the same if the command is followed by a <cr> except that a <cr><lf> is automatically inserted into the text following character c<sub>n</sub>. Consider the following command sequences as examples of the F and I commands:

<u>Command String</u>	<u>Effect</u>	<u>Resulting Memory Buffer</u>
BITHIS IS ↑z<cr>	Insert "THIS IS " at the beginning of the text	THIS IS NOW THE <cr><lf>  TIME FOR<cr><lf> ALL GOOD MEN<cr><lf>

FTIME+z-4DIPLACE+z<cr>

find "TIME" and delete it; then insert "PLACE"

THIS IS NOW THE<cr><lf>

PLACE  FOR<cr><lf>  
ALL GOOD MEN<cr><lf>

3FO+z-3D5DICHANGES+<cr>

find third occurrence of "O" (ie the second "O" in GOOD), delete previous 3 characters; then insert "CHANGES"

THIS IS NOW THE <cr><lf>

PLACE FOR<cr><lf>  
ALL CHANGES  <cr><lf>

-8CISOURCE<cr> move back 8 characters and insert the line "SOURCE<cr><lf>"

THIS IS NOW THE<cr><lf>

PLACE FOR<cr><lf>  
ALL SOURCE<cr><lf>

 CHANGES<cr><lf>

ED also provides a single command which combines the F and I commands to perform simple string substitutions. The command takes the form

$n S c_1 c_2 \dots c_k \uparrow z d_1 d_2 \dots d_m \left\{ \begin{array}{l} \langle cr \rangle \\ \uparrow z \end{array} \right\}$

and has exactly the same effect as applying the command string

$F c_1 c_2 \dots c_k \uparrow z -k D I d_1 d_2 \dots d_m \left\{ \begin{array}{l} \langle cr \rangle \\ \uparrow z \end{array} \right\}$

a total of n times. That is, ED searches the memory buffer starting at the current position of CP and successively substitutes the second string for the first string until the end of buffer, or until the substitution has been performed n times.

As a convenience, a command similar to F is provided by ED which automatically appends and writes lines as the search proceeds. The form is

$n N c_1 c_2 \dots c_k \left\{ \begin{array}{l} cr \\ \uparrow z \end{array} \right\}$

which searches the entire source file for the nth occurrence of the string  $c_1 c_2 \dots c_k$  (recall that F fails if the string cannot be found in the current buffer). The operation of the



N command is precisely the same as F except in the case that the string cannot be found within the current memory buffer. In this case, the entire memory contents is written (ie, an automatic #W is issued). Input lines are then read until the buffer is at least half full, or the entire source file is exhausted. The search continues in this manner until the string has been found n times, or until the source file has been completely transferred to the temporary file.

A final line editing function, called the juxtaposition command takes the form

$$n J c_1 c_2 \dots c_k \uparrow z d_1 d_2 \dots d_m \uparrow z e_1 e_2 \dots e_q \left\{ \begin{array}{l} \langle \text{cr} \rangle \\ \uparrow z \end{array} \right\}$$

with the following action applied n times to the memory buffer: search from the current CP for the next occurrence of the string  $c_1 c_2 \dots c_k$ . If found, insert the string  $d_1 d_2 \dots d_m$ , and move CP to follow  $d_m$ . Then delete all characters following CP up to (but not including) the string  $e_1 e_2 \dots e_q$ , leaving CP directly after  $d_m$ . If  $e_1 e_2 \dots e_q$  cannot be found, then no deletion is made. If the current line is

 NOW IS THE TIME <cr><lf>

Then the command

JW  $\uparrow z$ WHAT $\uparrow z \uparrow l$ <cr>

Results in

NOW WHAT  <cr><lf>

(Recall that  $\uparrow l$  represents the pair <cr><lf> in search and substitute strings).

It should be noted that the number of characters allowed by ED in the F,S,N, and J commands is limited to 100 symbols.

### 1.8. Source Libraries

ED also allows the inclusion of source libraries during the editing process with the R command. The form of this command is

R f<sub>1</sub>f<sub>2</sub>..f<sub>n</sub>↑z      or

R f<sub>1</sub>f<sub>2</sub>..f<sub>n</sub><cr>

where f<sub>1</sub>f<sub>2</sub>..f<sub>n</sub> is the name of a source file on the disk with as assumed filetype of 'LIB'. ED reads the specified file, and places the characters into the memory buffer after CP, in a manner similar to the I command. Thus, if the command

RMACRO<cr>

is issued by the operator, ED reads from the file MACRO.LIB until the end-of-file, and automatically inserts the characters into the memory buffer.

### 1.9. Repetitive Command Execution

The macro command M allows the ED user to group ED commands together for repeated evaluation. The M command takes the form:

$$n M c_1 c_2 \dots c_k \left\{ \begin{array}{l} \langle \text{cr} \rangle \\ \uparrow z \end{array} \right\}$$

where c<sub>1</sub>c<sub>2</sub>..c<sub>k</sub> represent a string of ED commands, not including another M command. ED executes the command string n times if n>1. If n=0 or 1, the command string is executed repetitively until an error condition is encountered (e.g., the end of the memory buffer is reached with an F command).

As an example, the following macro changes all occurrences of GAMMA to DELTA within the current buffer, and types each line which is changed:

MFGAMMA↑z-5DIDELTA↑z0TT<cr>

or equivalently

MSGAMMA↑zDELTA↑z0TT<cr>

## 2. ED ERROR CONDITIONS

On error conditions, ED prints the last character read before the error, along with an error indicator:

- ? unrecognized command
- > memory buffer full (use one of the commands D,K,N,S, or W to remove characters), F,N, or S strings too long.
- # cannot apply command the number of times specified (e.g., in F command)
- O cannot open LIB file in R command

Cyclic redundancy check (CRC) information is written with each output record under CP/M in order to detect errors on subsequent read operations. If a CRC error is detected, CP/M will type

PERM ERR DISK d

where d is the currently selected drive (A,B,...). The operator can choose to ignore the error by typing any character at the console (in this case, the memory buffer data should be examined to see if it was incorrectly read), or the user can reset the system and reclaim the backup file, if it exists. The file can be reclaimed by first typing the contents of the BAK file to ensure that it contains the proper information:

TYPE x.BAK<cr>

where x is the file being edited. Then remove the primary file:

ERA x.y<cr>

and rename the BAK file:

REN x.y=x.BAK<cr>

The file can then be re-edited, starting with the previous version.

### 3. CONTROL CHARACTERS AND COMMANDS

The following table summarizes the control characters and commands available in ED:

<u>Control Character</u>	<u>Function</u>
↑c	system reboot
↑e	physical <cr><lf> (not actually entered in command)
↑i	logical tab (cols 1,8,15,...)
↑l	logical <cr><lf> in search and substitute strings
↑u	line delete
↑z	string terminator
rubout	character delete
break	discontinue command (e.g., stop typing)

<u>Command</u>	<u>Function</u>
nA	append lines
±B	begin bottom of buffer
±nC	move character positions
±nD	delete characters
E	end edit and close files (normal end)
nF	find string
H	end edit, close and reopen files
I	insert characters
nJ	place strings in juxtaposition
±nK	kill lines
±nL	move down/up lines
nM	macro definition
nN	find next occurrence with autoscan
O	return to original file
±nP	move and print pages
Q	quit with no file changes
R	read library file
nS	substitute strings
±nT	type lines
± U	translate lower to upper case if U, no translation if -U
nW	write lines
nZ	sleep
±n<cr>	move and type (±nLT)



## Appendix A: ED 1.4 Enhancements

The ED context editor contains a number of commands which enhance its usefulness in text editing. The improvements are found in the addition of line numbers, free space interrogation, and improved error reporting.

The context editor issued with CP/M 1.4 produces absolute line number prefixes when the "V" (Verify Line Numbers) command is issued. Following the V command, the line number is displayed ahead of each line in the format:

nnnnn:

where nnnnn is an absolute line number in the range 1 to 65535. If the memory buffer is empty, or if the current line is at the end of the memory buffer, then nnnnn appears as 5 blanks.

The user may reference an absolute line number by preceding any command by a number followed by a colon, in the same format as the line number display. In this case, the ED program moves the current line reference to the absolute line number, if the line exists in the current memory buffer. Thus, the command

345:T

is interpreted as "move to absolute line 345, and type the line." Note that absolute line numbers are produced only during the editing process, and are not recorded with the file. In particular, the line numbers will change following a deleted or expanded section of text.

The user may also reference an absolute line number as a backward or forward distance from the current line by preceding the absolute line number by a colon. Thus, the command

:400T

is interpreted as "type from the current line number through the line whose absolute number is 400." Combining the two line reference forms, the command

345::400T

for example, is interpreted as "move to absolute line 345, then type through absolute line 400." Note that absolute line references of this sort can precede any of the standard ED commands.

A special case of the V command, "0V", prints the memory buffer statistics in the form:

free/total

where "free" is the number of free bytes in the memory buffer (in decimal), and "total" is the size of the memory buffer.

ED 1.4 also includes a "block move" facility implemented through the "X" (Xfer) command. The form

nX

transfers the next n lines from the current line to a temporary file called

X\$\$\$\$\$\$\$.LIB

which is active only during the editing process. In general, the user can reposition the current line reference to any portion of the source file and transfer lines to the temporary file. The transferred lines accumulate one after another in this file, and can be retrieved by simply typing:

R

which is the trivial case of the library read command. In this case, the entire transferred set of lines is read into the memory buffer. Note that the X command does not remove the transferred lines from the memory buffer, although a K command can be used directly after the X, and the R command does not empty the transferred line file. That is, given that a set of lines has been transferred with the X command, they can be re-read any number of times back into the source file. The command

ØX

is provided, however, to empty the transferred line file.

Note that upon normal completion of the ED program through Q or E, the temporary LIB file is removed. If ED is aborted through ctl-C, the LIB file will exist if lines have been transferred, but will generally be empty (a subsequent ED invocation will erase the temporary file).

Due to common typographical errors, ED 1.4 requires several potentially disastrous commands to be typed as single letters, rather than in composite commands. The commands

E (end), H (head), O (original), Q (quit)

must be typed as single letter commands.

ED 1.4 also prints error messages in the form

BREAK "x" AT c

where x is the error character, and c is the command where the error occurred.



**CP/M DYNAMIC DEBUGGING TOOL (DDT): USER'S GUIDE**

## COPYRIGHT

Copyright (c) 1980 by Exidy Systems, Inc. All rights reserved. No part of this publication may be reproduced, transmitted, transcribed, stored in a retrieval system, or translated into any language, in any form or by any means, electronic, mechanical, magnetic, optical, chemical, manual, or otherwise, without the prior written permission of Exidy Systems, Inc., 1234 Elko Drive, Sunnyvale, California 94086.

Since this manual is tutorial in nature, permission is granted to reproduce or abstract the example procedures and sample programs for the purposes of inclusion within the reader's programs.

## DISCLAIMER

Exidy Systems, Inc. makes no representations or warranties with respect to the contents hereof and specifically disclaims any implied warranties of merchantability or fitness for any particular purpose. Further, Exidy Systems, Inc. reserves the right to revise this publication and to make changes from time to time in the content hereof without obligation of Exidy Systems, Inc. to notify any person of such revision or changes.

## TRADEMARKS

CP/M is a registered trademark of Digital Research.

**CP/M DYNAMIC DEBUGGING TOOL (DDT): USER'S GUIDE**

## COPYRIGHT

Copyright (c) 1980 by Exidy Systems, Inc. All rights reserved. No part of this publication may be reproduced, transmitted, transcribed, stored in a retrieval system, or translated into any language, in any form or by any means, electronic, mechanical, magnetic, optical, chemical, manual, or otherwise, without the prior written permission of Exidy Systems, Inc., 1234 Elko Drive, Sunnyvale, California 94086.

Since this manual is tutorial in nature, permission is granted to reproduce or abstract the example procedures and sample programs for the purposes of inclusion within the reader's programs.

## DISCLAIMER

Exidy Systems, Inc. makes no representations or warranties with respect to the contents hereof and specifically disclaims any implied warranties of merchantability or fitness for any particular purpose. Further, Exidy Systems, Inc. reserves the right to revise this publication and to make changes from time to time in the content hereof without obligation of Exidy Systems, Inc. to notify any person of such revision or changes.

## TRADEMARKS

CP/M is a registered trademark of Digital Research.

## Table Of Contents

### CP/M Debugging Tool (DDT): User's Guide

I.	Introduction.....	111
II.	DDT Commands.....	113
	1. The A (Assemble) Command.....	113
	2. The D (Display) Command.....	114
	3. The F (Fill) Command.....	114
	4. The G (Go) Command.....	114
	5. The I (Input) Command.....	115
	6. The L (List) Command.....	116
	7. The M (Move) Command.....	116
	8. The R (Read) Command.....	116
	9. The S (Set) Command.....	117
	10. The T (Trace) Command.....	117
	11. The U (Untrace) Command.....	118
	12. The X (Examine) Command.....	118
III.	Implementation Notes.....	119
IV.	An Example.....	120



## CP/M Dynamic Debugging Tool (DDT)

### User's Guide

#### I. Introduction.

The DDT program allows dynamic interactive testing and debugging of programs generated in the CP/M environment. The debugger is initiated by typing one of the following commands at the CP/M Console Command level

```
DDT
DDT filename.HEX
DDT filename.COM
```

where "filename" is the name of the program to be loaded and tested. In both cases, the DDT program is brought into main memory in the place of the Console Command Processor (refer to the CP/M Interface Guide for standard memory organization), and thus resides directly below the Basic Disk Operating System portion of CP/M. The BDOS starting address, which is located in the address field of the JMP instruction at location 5H, is altered to reflect the reduced Transient Program Area size.

The second and third forms of the DDT command shown above perform the same actions as the first, except there is a subsequent automatic load of the specified HEX or COM file. The action is identical to the sequence of commands

```
DDT
Ifilename.HEX or Ifilename.COM
R
```

where the I and R commands set up and read the specified program to test (see the explanation of the I and R commands below for exact details).

Upon initiation, DDT prints a sign-on message in the format

```
nnK DDT-s VER m.m
```

where nn is the memory size (which must match the CP/M system being used), s is the hardware system which is assumed, corresponding to the codes

```
D - Digital Research standard version
M - MDS version
I - IMSAI standard version
O - Omron systems
S - Digital Systems standard version
```

and m.m is the revision number.

Following the sign on message, DDT prompts the operator with the character "-" and waits for input commands from the console. The operator can type any of several single character commands, terminated by a carriage return to execute the command. Each line of input can be line-edited using the standard CP/M controls

rubout	remove the last character typed
ctl-U	remove the entire line, ready for re-typing
ctl-C	system reboot

Any command can be up to 32 characters in length (an automatic carriage return is inserted as the 33rd character), where the first character determines the command type

A	enter assembly language mnemonics with operands
D	display memory in hexadecimal and ASCII
F	fill memory with constant data
G	begin execution with optional breakpoints
I	set up a standard input file control block
L	list memory using assembler mnemonics
M	move a memory segment from source to destination
R	read program for subsequent testing
S	substitute memory values
T	trace program execution
U	untraced program monitoring
X	examine and optionally alter the CPU state

The command character, in some cases, is followed by zero, one, two, or three hexadecimal values which are separated by commas or single blank characters. All DDT numeric output is in hexadecimal form. In all cases, the commands are not executed until the carriage return is typed at the end of the command.

At any point in the debug run, the operator can stop execution of DDT using either a ctl-C or G0 (jmp to location 0000H), and save the current memory image using a SAVE command of the form

SAVE n filename.COM

where n is the number of pages (256 byte blocks) to be saved on disk. The number of blocks can be determined by taking the high order byte of the top load address and converting this number to decimal. For example, if the highest address in the Transient Program Area is 1234H then the number of pages is 12H, or 18 in decimal. Thus the operator could type a ctl-C during the debug run, returning to the Console Processor level, followed by

SAVE 18 X.COM

The memory image is saved as X.COM on the diskette, and can be directly executed by simply typing the name X. If further testing is required, the memory image can be recalled by typing



## DDT X.COM

which reloads previously saved program from loaction 100H through page 18 (12FFH). The machine state is not a part of the COM file, and thus the program must be restarted from the beginning in order to properly test it.

## II. DDT COMMANDS.

The individual commands are given below in some detail. In each case, the operator must wait for the prompt character (-) before entering the command. If control is passed to a program under test, and the program has not reached a breakpoint, control can be returned to DDT by executing a RST 7 from the front panel (note that the rubout key should be used instead if the program is executing a T or U command). In the explanation of each command, the command letter is shown in some cases with numbers separated by commas, where the numbers are represented by lower case letters. These numbers are always assumed to be in a hexadecimal radix, and from one to four digits in length (longer numbers will be automatically truncated on the right).

Many of the commands operate upon a "CPU state" which corresponds to the program under test. The CPU state holds the registers of the program being debugged, and initially contains zeroes for all registers and flags except for the program counter (P) and stack pointer (S), which default to 100H. The program counter is subsequently set to the starting address given in the last record of a HEX file if a file of this form is loaded (see the I and R commands).

1. The A (Assemble) Command. DDT allows inline assembly language to be inserted into the current memory image using the A command which takes the form

As

where s is the hexadecimal starting address for the inline assembly. DDT prompts the console with the address of the next instruction to fill, and reads the console, looking for assembly language mnemonics (see the Intel 8080 Assembly Language Reference Card for a list of mnemonics), followed by register references and operands in absolute hexadecimal form. Each successive load address is printed before reading the console. The A command terminates when the first empty line is input from the console.

Upon completion of assembly language input, the operator can review the memory segment using the DDT disassembler (see the L command).

Note that the assembler/disassembler portion of DDT can be overlaid by the transient program being tested, in which case the DDT program responds with an error condition when the A and L commands are used (refer to Section IV).

2. The D (Display) Command. The D command allows the operator to view the contents of memory in hexadecimal and ASCII formats. The forms are

D  
Ds  
Ds,f

In the first case, memory is displayed from the current display address (initially 100H), and continues for 16 display lines. Each display line takes the form shown below

aaaa bb bb bb bb bb bb bb bb bb bb bb bb bb bb cccccccccccccccc

where aaaa is the display address in hexadecimal, and bb represents data present in memory starting at aaaa. The ASCII characters starting at aaaa are given to the right (represented by the sequence of c's), where non-graphic characters are printed as a period (.) symbol. Note that both upper and lower case alphabetic characters are displayed, and thus will appear as upper case symbols on a console device that supports only upper case. Each display line gives the values of 16 bytes of data, except that the first line displayed is truncated so that the next line begins at an address which is a multiple of 16.

The second form of the D command shown above is similar to the first, except that the display address is first set to address s. The third form causes the display to continue from address s through address f. In all cases, the display address is set to the first address not displayed in this command, so that a continuing display can be accomplished by issuing successive D commands with no explicit addresses.

Excessively long displays can be aborted by pushing the rubout key.

3. The F (Fill) Command. The F command takes the form

Fs,f,c

where s is the starting address, f is the final address, and c is a hexadecimal byte constant. The effect is as follows: DDF stores the constant c at address s, increments the value of s and tests against f. If s exceeds f then the operation terminates, otherwise the operation is repeated. Thus, the fill command can be used to set a memory block to a specific constant value.

4. The G (Go) Command. Program execution is started using the G command, with up to two optional breakpoint addresses. The G command takes one of the forms

G  
Gs  
Gs,b

Gs,b,c

G,b

G,b,c

The first form starts execution of the program under test at the current value of the program counter in the current machine state, with no breakpoints set (the only way to regain control in DDT is through a RST 7 execution). The current program counter can be viewed by typing an X or XP command. The second form is similar to the first except that the program counter in the current machine state is set to address s before execution begins. The third form is the same as the second, except that program execution stops when address b is encountered (b must be in the area of the program under test). The instruction at location b is not executed when the breakpoint is encountered. The fourth form is identical to the third, except that two breakpoints are specified, one at b and the other at c. Encountering either breakpoint causes execution to stop, and both breakpoints are subsequently cleared. The last two forms take the program counter from the current machine state, and set one and two breakpoints, respectively.

Execution continues from the starting address in real-time to the next breakpoint. That is, there is no intervention between the starting address and the break address by DDT. Thus, if the program under test does not reach a breakpoint, control cannot return to DDT without executing a RST 7 instruction. Upon encountering a breakpoint, DDT stops execution and types

\*d

where d is the stop address. The machine state can be examined at this point using the X (Examine) command. The operator must specify breakpoints which differ from the program counter address at the beginning of the G command. Thus, if the current program counter is 1234H, then the commands

G,1234

and

G400,400

both produce an immediate breakpoint, without executing any instructions whatsoever.

5. The I (Input) Command. The I command allows the operator to insert a file name into the default file control block at 5CH (the file control block created by CP/M for transient programs is placed at this location; see the CP/M Interface Guide). The default FCB can be used by the program under test as if it had been passed by the CP/M Console Processor. Note that this file name is also used by DDT for reading additional HEX and COM files. The form of the I command is

Ifilename

or

Ifilename.filetype

If the second form is used, and the filetype is either HEX or COM, then subsequent R commands can be used to read the pure binary or hex format machine code (see the R command for further details).

6. The L (List) Command. The L command is used to list assembly language mnemonics in a particular program region. The forms are

L  
Ls  
Ls,f

The first command lists twelve lines of disassembled machine code from the current list address. The second form sets the list address to s, and then lists twelve lines of code. The last form lists disassembled code from s through address f. In all three cases, the list address is set to the next unlisted location in preparation for a subsequent L command. Upon encountering an execution breakpoint, the list address is set to the current value of the program counter (see the G and T commands). Again, long typeouts can be aborted using the rubout key during the list process.

7. The M (Move) Command. The M command allows block movement of program or data areas from one location to another in memory. The form is

Ms,f,d

where s is the start address of the move, f is the final address of the move, and d is the destination address. Data is first moved from s to d, and both addresses are incremented. If s exceeds f then the move operation stops, otherwise the move operation is repeated.

8. The R (Read) Command. The R command is used in conjunction with the I command to read COM and HEX files from the diskette into the transient program area in preparation for the debug run. The forms are

R  
Rb

where b is an optional bias address which is added to each program or data address as it is loaded. The load operation must not overwrite any of the system parameters from 000H through 0FFH (i.e., the first page of memory). If b is omitted, then b=0000 is assumed. The R command requires a previous I command, specifying the name of a HEX or COM file. The load address for each record is obtained from each individual HEX record, while an assumed load address of 100H is taken for COM files. Note that any number of R commands can be issued following the I command to re-read the program under test,

assuming the tested program does not destroy the default area at 5CH. Further, any file specified with the filetype "COM" is assumed to contain machine code in pure binary form (created with the LOAD or SAVE command), and all others are assumed to contain machine code in Intel hex format (produced, for example, with the ASM command).

Recall that the command

```
DDT filename.filetype
```

which initiates the DDT program is equivalent to the commands

```
DDT  
-I filename.filetype  
-R
```

Whenever the R command is issued, DDT responds with either the error indicator "?" (file cannot be opened, or a checksum error occurred in a HEX file), or with a load message taking the form

```
NEXT PC  
nnnn pppp
```

where nnnn is the next address following the loaded program, and pppp is the assumed program counter (100H for COM files, or taken from the last record if a HEX file is specified).

9. The S (Set) Command. The S command allows memory locations to be examined and optionally altered. The form of the command is

```
Ss
```

where s is the hexadecimal starting address for examination and alteration of memory. DDT responds with a numeric prompt, giving the memory location, along with the data currently held in the memory location. If the operator types a carriage return, then the data is not altered. If a byte value is typed, then the value is stored at the prompted address. In either case, DDT continues to prompt with successive addresses and values until either a period (.) is typed by the operator, or an invalid input value is detected.

10. The T (Trace) Command. The T command allows selective tracing of program execution for 1 to 65535 program steps. The forms are

```
T  
Tn
```

In the first case, the CPU state is displayed, and the next program step is executed. The program terminates immediately, with the termination address

displayed as

\*hhhh

where hhhh is the next address to execute. The display address (used in the D command) is set to the value of H and L, and the list address (used in the L command) is set to hhhh. The CPU state at program termination can then be examined using the X command.

The second form of the T command is similar to the first, except that execution is traced for n steps (n is a hexadecimal value) before a program breakpoint is occurs. A breakpoint can be forced in the trace mode by typing a rubout character. The CPU state is displayed before each program step is taken in trace mode. The format of the display is the same as described in the X command.

Note that program tracing is discontinued at the interface to CP/M, and resumes after return from CP/M to the program under test. Thus, CP/M functions which access I/O devices, such as the diskette drive, run in real-time, avoiding I/O timing problems. Programs running in trace mode execute approximately 500 times slower than real time since DDT gets control after each user instruction is executed. Interrupt processing routines can be traced, but it must be noted that commands which use the breakpoint facility (G, T, and U) accomplish the break using a RST 7 instruction, which means that the tested program cannot use this interrupt location. Further, the trace mode always runs the tested program with interrupts enabled, which may cause problems if asynchronous interrupts are received during tracing.

Note also that the operator should use the rubout key to get control back to DDT during trace, rather than executing a RST 7, in order to ensure that the trace for the current instruction is completed before interruption.

11. The U (Untrace) Command. The U command is identical to the T command except that intermediate program steps are not displayed. The untrace mode allows from 1 to 65535 (0FFFFH) steps to be executed in monitored mode, and is used principally to retain control of an executing program while it reaches steady state conditions. All conditions of the T command apply to the U command.

12. The X (Examine) Command. The X command allows selective display and alteration of the current CPU state for the program under test. The forms are

X  
Xr

where r is one of the 8080 CPU registers

C	Carry Flag	(0/1)
Z	Zero Flag	(0/1)

M	Minus Flag	(0/1)
E	Even Parity Flag	(0/1)
I	Interdigit Carry	(0/1)
A	Accumulator	(0-FF)
B	BC register pair	(0-FFFF)
D	DE register pair	(0-FFFF)
H	HL register pair	(0-FFFF)
S	Stack Pointer	(0-FFFF)
P	Program Counter	(0-FFFF)

In the first case, the CPU register state is displayed in the format

CfZfMfEfIf A=bb B=dddd D=dddd H=dddd S=dddd P=dddd inst

where f is a 0 or 1 flag value, bb is a byte value, and dddd is a double byte quantity corresponding to the register pair. The "inst" field contains the disassembled instruction which occurs at the location addressed by the CPU state's program counter.

The second form allows display and optional alteration of register values, where r is one of the registers given above (C, Z, M, E, I, A, B, D, H, S, or P). In each case, the flag or register value is first displayed at the console. The DDT program then accepts input from the console. If a carriage return is typed, then the flag or register value is not altered. If a value in the proper range is typed, then the flag or register value is altered. Note that BC, DE, and HL are displayed as register pairs. Thus, the operator types the entire register pair when B, C, or the BC pair is altered.

### III. IMPLEMENTATION NOTES.

The organization of DDT allows certain non-essential portions to be overlaid in order to gain a larger transient program area for debugging large programs. The DDT program consists of two parts: the DDT nucleus and the assembler/disassembler module. The DDT nucleus is loaded over the Console Command Processor, and, although loaded with the DDT nucleus, the assembler/disassembler is overlayable unless used to assemble or disassemble.

In particular, the BDOS address at location 6H (address field of the JMP instruction at location 5H) is modified by DDT to address the base location of the DDT nucleus which, in turn, contains a JMP instruction to the BDOS. Thus, programs which use this address field to size memory see the logical end of memory at the base of the DDT nucleus rather than the base of the BDOS.

The assembler/disassembler module resides directly below the DDT nucleus in the transient program area. If the A, L, T, or X commands are used during the debugging process then the DDT program again alters the address field at 6H to include this module, thus further reducing the logical end of memory. If a program loads beyond the beginning of the assembler/disassembler module, the A and L commands are lost (their use produces a "?" in response), and the

trace and display (T and X) commands list the "inst" field of the display in hexadecimal, rather than as a decoded instruction.

#### IV. AN EXAMPLE.

The following example shows an edit, assemble, and debug for a simple program which reads a set of data values and determines the largest value in the set. The largest value is taken from the vector, and stored into "LARGE" at the termination of the program

```

ED SCAN.ASM
*1, 1-1  ORG 100H  ;L-START OF TRANSIENT AREA,
      MVI B,LEN  ;LENGTH OF VECTOR TO SCAN,
      MVI C,0    ;LARGER-RST VALUE SO FAR,
LOOP:  LXI H,VECT ;BASE OF VECTOR,
      MOV A,M    ;GET VALUE,
      SUB C      ;LARGER VALUE IN C?,
      JNC NFOUND ;JUMP IF LARGER VALUE NOT FOUND,
      NEW LARGEST VALUE, STORE IT TO C,
      MOV C,A
NFOUND: INX H    ;TO NEXT ELEMENT,
        DCR B    ;MORE TO SCAN?,
        JNZ LOOP ;FOR ANOTHER,

      END OF SCAN, STORE C,
      MOV A,C    ;GET LARGEST VALUE,
      STA LARGE,
      JMP A      ;REBOOT,

TEST DATA
VECT:  DB 2,0,4,3,5,6,1,5,
LEN:   EQU $-VECT ;LENGTH,
LARGE: DS 1       ;LARGEST VALUE ON EXIT,
END,

```

```

*00P,
ORG 100H ;START OF TRANSIENT AREA
MVI B,LEN ;LENGTH OF VECTOR TO SCAN
MVI C,0 ;LARGER VALUE SO FAR
LXI H,VECT ;BASE OF VECTOR
LOOP: MOV A,M ;GET VALUE
      SUB C ;LARGER VALUE IN C?
      JNC NFOUND ;JUMP IF LARGER VALUE NOT FOUND
      NEW LARGEST VALUE, STORE IT TO C
      MOV C,A
NFOUND: INX H ;TO NEXT ELEMENT
        DCR B ;MORE TO SCAN?
        JNZ LOOP ;FOR ANOTHER

```

Create Source Program - underlined characters typed by programmer. ";" represents carriage return.



```

END OF SCAN, STORE C
MOV     A,C       ;GET LARGEST VALUE
STA     LARGE
JMP     0         ;REBOOT

```

```

TEST DATA
VECT:   DB       2,0,4,3,5,6,1,5
LEN     EQU     $-VECT ;LENGTH
LARGE:  DS       1     ;LARGEST VALUE ON EXIT
END

```

\*E, ← End of Edit

ASM SCAN, Start Assembler

CP/M ASSEMBLER - VER 1.0

```

0122
002H USE FACTOR
END OF ASSEMBLY

```

Assembly Complete - Look at Program Listing

TYPE SCAN.PRN,

<p>Code Address</p> <pre> 0100 Machine Code 0100 0608 0102 0E00 0104 211901 0107 7E 0108 91 0109 D20D01  010C 4F 010D 23 010E 05 010F C20701  0112 79 0113 322101 0116 C30000 0119 0200040305 0008 = 0121 Value of 0122 Equate </pre>	<p>Source Program</p> <pre> ORG     100H       ;START OF TRANSIENT AREA MVI     B,LEN     ;LENGTH OF VECTOR TO SCAN MVI     C,0       ;LARGEST VALUE SO FAR LXI     H,VECT   ;BASE OF VECTOR LOOP:   MOV     A,M ;GET VALUE         SUB     C ;LARGER VALUE IN C?         JNC    NFOUND ;JUMP IF LARGER VALUE NOT FOUND         NEW LARGEST VALUE, STORE IT TO C         MOV     C,A NFOUND: INX     H ;TO NEXT ELEMENT         DCR     B ;MORE TO SCAN?         JNZ    LOOP ;FOR ANOTHER  END OF SCAN, STORE C MOV     A,C       ;GET LARGEST VALUE STA     LARGE JMP     0         ;REBOOT  TEST DATA DB     2,0,4,3,5,6,1,5 EQU    \$-VECT ;LENGTH DS     1         ;LARGEST VALUE ON EXIT END </pre>
---	--

A>

DDT SCAN.HEX,

Start Debugger using hex format machine code

16K DDT VER 1.0

NEXT PC

0121 0000

-X, last load address + 1

C0Z0M0E010 A=00 B=0000 D=0000 H=0000 S=0100 P=0000 OUT 7F PC=0

-XP, Examine registers before debug run

P=0000 100, Change PC to 100

-X, Look at registers again

C0Z0M0E010 A=00 B=0000 D=0000 H=0000 S=0100 P=0100 MVI B,00

-L100,

```

0100 MVI B,00
0102 MVI C,00
0104 LXI H,0119
0107 MOV A,M
0108 SUB C
0109 JNC 010D
010C MOV C,A
010D INX H
010E DCR B
010F JNZ 0107
0112 MOV A,C

```

Disassembled Machine Code at 100H. (See Source Listing for comparison)

Next instruction to execute at PC=100

-L,

```

0113 STA 0121
0116 JMP 0000
0119 STAX B
011A NOP
011B INR B
011C INX B
011D DCR B
011E MVI B,01
0120 DCR B
0121 LXI D,2200
0124 LXI H,0200

```

A little more machine code (note that program ends at location 116 with a JMP to 0000)

-A116, enter inline assembly mode to change the JMP to 0000 into a RST 7, which will cause the program under test to return to DDT if 116H is ever executed.

0116 RST 7,

0117, (single carriage return stops assemble mode)

-L113, List code at 113H to check that RST 7 was properly inserted

0113 STA 0121  
0116 RST 07

in place of JMP

```

0117 NOP
0118 NOP
0119 STAX B
011A NOP
011B INR B
011C INX B

```

-X, Look at registers

```

C0Z0M0E010 A=00 B=0000 D=0000 H=0000 S=0100 P=0100 MVI B,00

```

-I, Execute Program for one step. initial CPU state, before is executed

```

C0Z0M0E010 A=00 B=0000 D=0000 H=0000 S=0100 P=0100 MVI B,00+0102

```

-I, Trace one step again (note CPU in B) automatic breakpoint

```

C0Z0M0E010 A=00 B=0800 D=0000 H=0000 S=0100 P=0102 MVI C,00+0104

```

-I, Trace again (Register C is cleared)

```

C0Z0M0E010 A=00 B=0800 D=0000 H=0000 S=0100 P=0104 LXI H,0119+0107

```

-I3, Trace three steps

```

C0Z0M0E010 A=00 B=0800 D=0000 H=0119 S=0100 P=0107 MOV A,M

```

```

C0Z0M0E010 A=02 B=0800 D=0000 H=0119 S=0100 P=0108 SUB C

```

```

C0Z0M0E011 A=02 B=0800 D=0000 H=0119 S=0100 P=0109 JNC 010D+010D

```

-D119, Display memory starting at 119H.

0119	02	00	04	03	05	06	01	Program data								automatic breakpoint at 10DH											
0120	05	11	00	22	21	00	02	7E	EB	77	13	23	EB	0B	78	B1	Lowercase X										
0130	C2	27	01	C3	03	29	00	00	00	00	00	00	00	00	00	00	00	Data is displayed in ASCII with a '0' in the position of non-graphic characters.									
0140	00	00	00	00	00	00	00	00	00	00	00	00	00	00	00	00	00										
0150	00	00	00	00	00	00	00	00	00	00	00	00	00	00	00	00	00										
0160	00	00	00	00	00	00	00	00	00	00	00	00	00	00	00	00	00										
0170	00	00	00	00	00	00	00	00	00	00	00	00	00	00	00	00	00										
0180	00	00	00	00	00	00	00	00	00	00	00	00	00	00	00	00	00										
0190	00	00	00	00	00	00	00	00	00	00	00	00	00	00	00	00	00										
01A0	00	00	00	00	00	00	00	00	00	00	00	00	00	00	00	00	00										
01B0	00	00	00	00	00	00	00	00	00	00	00	00	00	00	00	00	00										
01C0	00	00	00	00	00	00	00	00	00	00	00	00	00	00	00	00	00										

-X, Current CPU state

```

C0Z0M0E011 A=02 B=0800 D=0000 H=0119 S=0100 P=010D INX H

```

-I5, Trace 5 steps from current CPU state

```

C0Z0M0E011 A=02 B=0800 D=0000 H=0119 S=0100 P=010D INX H

```

```

C0Z0M0E011 A=02 B=0800 D=0000 H=011A S=0100 P=010E DCR B

```

```

C0Z0M0E011 A=02 B=0700 D=0000 H=011A S=0100 P=010F JNZ 0107

```

```

C0Z0M0E011 A=02 B=0700 D=0000 H=011A S=0100 P=0107 MOV A,M

```

```

C0Z0M0E011 A=00 B=0700 D=0000 H=011A S=0100 P=0108 SUB C*0109

```

-U5, Trace without listing intermediate states

```

C0Z1M0E111 A=00 B=0700 D=0000 H=011A S=0100 P=0109 JNC 010D+0108

```

-X, CPU state at end of U5

```

C0Z0M0E111 A=04 B=0600 D=0000 H=011B S=0100 P=0108 SUB C

```

-G, Run Program from current PC until completion (in real-time)  
 \*0116 breakpoint at 116H, caused by executing RST 7 in machine code

-X, CPU state at end of Program

C0Z1M0E111 A=00 B=0000 D=0000 H=0121 S=0100 P=0116 RST 07

-XP, examine and change Program Counter

P=0116 100,

-X,

C0Z1M0E111 A=00 B=0000 D=0000 H=0121 S=0100 P=0100 MVI B,08

-T10, Trace 10 (hexadecimal) steps

	A	B	D	H	S	P	Instruction	Comments
C0Z1M0E111	A=00	B=0000	D=0000	H=0121	S=0100	P=0100	MVI B,08	
C0Z1M0E111	A=00	B=0000	D=0000	H=0121	S=0100	P=0102	MVI C,00	
C0Z1M0E111	A=00	B=0800	D=0000	H=0121	S=0100	P=0104	LXI H,0119	
C0Z1M0E111	A=00	B=0800	D=0000	H=0119	S=0100	P=0107	MOV A,M	
C0Z1M0E111	A=02	B=0800	D=0000	H=0119	S=0100	P=0108	SUB C	Subtract for comparison ACC
C0Z0M0E011	A=02	B=0800	D=0000	H=0119	S=0100	P=0109	JNC 010D	
C0Z0M0E011	A=02	B=0800	D=0000	H=0119	S=0100	P=010D	INX H	
C0Z0M0E011	A=02	B=0800	D=0000	H=011A	S=0100	P=010E	DCR B	
C0Z0M0E011	A=02	B=0700	D=0000	H=011A	S=0100	P=010F	JNZ 0107	
C0Z0M0E011	A=02	B=0700	D=0000	H=011A	S=0100	P=0107	MOV A,M	
C0Z0M0E011	A=00	B=0700	D=0000	H=011A	S=0100	P=0108	SUB C	
C0Z1M0E111	A=00	B=0700	D=0000	H=011A	S=0100	P=0109	JNC 010D	
C0Z1M0E111	A=00	B=0700	D=0000	H=011A	S=0100	P=010D	INX H	
C0Z1M0E111	A=00	B=0700	D=0000	H=011B	S=0100	P=010E	DCR B	
C0Z0M0E111	A=00	B=0600	D=0000	H=011B	S=0100	P=010F	JNZ 0107	
C0Z0M0E111	A=00	B=0600	D=0000	H=011B	S=0100	P=0107	MOV A,M*0108	

first data element current largest value subtract for comparison ACC

-A109, Insert a "hot patch" into

0109 JC 10D, the machine code

010C, to change the

JNC to JC

-G, Stop DDT so that a version of the patched program can be saved

Program should have moved the value from A into C since A > C. Since this code was not executed, it appears that the JNC should have been a JC instruction

SAVE 1 SCAN.COM, Program resides on first page, so save 1 page.

A>DDT SCAN.COM, Restart DDT with the saved memory image to continue testing

16K DDT VER 1.0  
 NEXT PC  
 0200 0100

-L100, List some code

0100 MVI B,08  
 0102 MVI C,00  
 0104 LXI H,0119  
 0107 MOV A,M  
 0108 SUB C  
 0109 JC 010D

Previous patch is present in X.COM

```

010C MOV C, A
010D INX H
010E DCR B
010F JNZ 0107
0112 MOV A, C

```

-XP,

P=0100,

-T10, Trace to see how patched version operates Data is moved from A to C

```

C0Z0M0E010 A=00 B=0000 D=0000 H=0000 S=0100 P=0100 MVI B,00
C0Z0M0E010 A=00 B=0800 D=0000 H=0000 S=0100 P=0102 MVI C,00
C0Z0M0E010 A=00 B=0800 D=0000 H=0000 S=0100 P=0104 LXI H,0119
C0Z0M0E010 A=00 B=0800 D=0000 H=0119 S=0100 P=0107 MOV A,M
C0Z0M0E010 A=02 B=0800 D=0000 H=0119 S=0100 P=0108 SUB C
C0Z0M0E011 A=02 B=0800 D=0000 H=0119 S=0100 P=0109 JC 010D
C0Z0M0E011 A=02 B=0802 D=0000 H=0119 S=0100 P=010C MOV C,A
C0Z0M0E011 A=02 B=0802 D=0000 H=0119 S=0100 P=010D INX H
C0Z0M0E011 A=02 B=0702 D=0000 H=011A S=0100 P=010E DCR B
C0Z0M0E011 A=02 B=0702 D=0000 H=011A S=0100 P=010F JNZ 0107
C0Z0M0E011 A=02 B=0702 D=0000 H=011A S=0100 P=0107 MOV A,M
C0Z0M0E011 A=00 B=0702 D=0000 H=011A S=0100 P=0108 SUB C
C1Z0M1E010 A=FE B=0702 D=0000 H=011A S=0100 P=0109 JC 010D
C1Z0M1E010 A=FE B=0702 D=0000 H=011A S=0100 P=010D INX H
C1Z0M1E010 A=FE B=0702 D=0000 H=011B S=0100 P=010E DCR B
C1Z0M0E111 A=FE B=0602 D=0000 H=011B S=0100 P=010F JNZ 0107*0107

```

-X,

breakpoint after 16 steps

```
C1Z0M0E111 A=FE B=0602 D=0000 H=011B S=0100 P=0107 MOV A,M
```

-G, 108, Run from current PC and breakpoint at 108H

\*0108

-X,

next data item

```
C1Z0M0E111 A=04 B=0602 D=0000 H=011B S=0100 P=0108 SUB C
```

-I,

Single step for a few cycles

```
C1Z0M0E111 A=04 B=0602 D=0000 H=011B S=0100 P=0108 SUB C*0109
```

-I,

```
C0Z0M0E011 A=02 B=0602 D=0000 H=011B S=0100 P=0109 JC 010D*010C
```

-X,

```
C0Z0M0E011 A=02 B=0602 D=0000 H=011B S=0100 P=010C MOV C,A
```

-G, Run to completion

\*0116

-X,

```
C0Z1M0E111 A=03 B=0003 D=0000 H=0121 S=0100 P=0116 RST 07
```

-S121, look at the value of "LARGE"

0121 03, Wrong Value!

0122 00,

0123 22,

0124 21,

0125 00,

0126 02,

End of the S Command

0127 7E →

-L100,

```

0100 MVI B,08
0102 MVI C,00
0104 LXI H,0119
0107 MOV A,M
0108 SUB C
0109 JC 010D
010C MOV C,A
010D INX H
010E DCR B
010F JNZ 0107
0112 MOV A,C

```

Review the code

-L,

```

0113 STA 0121
0116 RST 07
0117 NOP
0118 NOP
0119 STAX B
011A NOP
011B INR B
011C INX B
011D DCR B
011E MVI B,01
0120 DCR B

```

-XP,

P=0116 100, Reset the PC

-I, Single step, and watch data values

C0Z1M0E111 A=03 B=0003 D=0000 H=0121 S=0100 P=0100 MVI B,08\*0102

-I,

C0Z1M0E111 A=03 B=0003 D=0000 H=0121 S=0100 P=0102 MVI C,00\*0104

-I,

C0Z1M0E111 A=03 B=0000 D=0000 H=0121 S=0100 P=0104 LXI H,0119\*0107

-I,

C0Z1M0E111 A=03 B=0000 D=0000 H=0119 S=0100 P=0107 MOV A,M\*0108

Count set largest set

base address of data set

```

-I,
C0Z0M0E011 A=02 B=0000 D=0000 H=0119 S=0100 P=0108 SUB C*0109
-I,
C0Z0M0E011 A=02 B=0000 D=0000 H=0119 S=0100 P=0109 JC 010D*010C
-I,
C0Z0M0E011 A=02 B=0000 D=0000 H=0119 S=0100 P=010C MOV C,A*010D
-I,
C0Z0M0E011 A=02 B=0002 D=0000 H=0119 S=0100 P=010D INX H*010E
-I,
C0Z0M0E011 A=02 B=0002 D=0000 H=011A S=0100 P=010E DCR B*010F
-I,
C0Z0M0E011 A=02 B=0702 D=0000 H=011A S=0100 P=010F JNZ 0107*0107
-I,
C0Z0M0E011 A=02 B=0702 D=0000 H=011A S=0100 P=0107 MOV A,M*0108
-I,
C0Z0M0E011 A=00 B=0702 D=0000 H=011A S=0100 P=0108 SUB C*0109
-I,
C1Z0M1E010 A=FE B=0702 D=0000 H=011A S=0100 P=0109 JC 010D*010D
-I,
C1Z0M1E010 A=FE B=0702 D=0000 H=011A S=0100 P=010D INX H*010E
-L100,
0100 MVI B,00
0102 MVI C,00
0104 LXI H,0119
0107 MOV A,M
0108 SUB C ← This should have been a CMP so that register A
0109 JC 010D would not be destroyed.
010C MOV C,A
010D INX H
010E DCR B
010F JNZ 0107
0112 MOV A,C
-A100,
0108 CMP C, hot patch at 100H changes SUB to CMP
0109,
-G0, stop DDT for SNE

```

SAVE 1 SCAN.COM,

Save memory image

A>DDT SCAN.COM,

Restart DDT

16K DDT VER 1.0

NEXT PC

0200 0100

-XP,

P=0100,

-L116,

0116 RST 07

0117 NOP

0118 NOP

0119 STAX B

011A NOP

- (rubout)

} Look at code to see if it was properly loaded  
(long timeout aborted with rubout)

-G.116, Run from look to completion

\*0116

-XC, Look at Carry (accidental typo)

C1,

-X, Look at CPU state

C1ZIMBE111 A=06 B=0006 D=0000 H=0121 S=0100 P=0116 RST 07

-S121, Look at "Large" - it appears to be correct.

0121 06,

0122 00,

0123 22 ,

-G0, stop DDT

ED SCAN.ASM,

Re-edit the source program, and make both changes

\*NSUB,

\*0LT,

SUB C  
\*SSUB ZCMP Z0LT, C

;LARGER VALUE IN C?

;LARGER VALUE IN C?

\*2

JNC  
\*SN ZC Z0LT,  
JC

NFOUND ;JUMP IF LARGER VALUE NOT FOUND

NFOUND ;JUMP IF LARGER VALUE NOT FOUND

\*E,



ASM SCAN.AAZ, Re-assemble, selecting source from disk A  
 hex to disk A  
 Print to Z (selects no print file)

0122  
 002H USE FACTOR  
 END OF ASSEMBLY

DDT SCAN.HEX, Re-run debugger to check changes

16K DDT VER 1.0  
 NEXT PC  
 0121 0000  
 -L116,

0116 JMP 0000 check to ensure end is still at 116H  
 0119 STAX B  
 011A NOP  
 011B INR B  
 - (rubbout)

-G100,116, Go from beginning with breakpoint at end

\*0116 breakpoint reached

-D121, Look at "LARGE" — correct value computed

```
0121 00 00 22 21 00 02 7E EB 77 13 23 EB 0B 7B B1 ... '!...M.B..X.
0130 C2 27 01 C3 03 29 00 00 00 00 00 00 00 00 00 ... ).....
0140 00 00 00 00 00 00 00 00 00 00 00 00 00 00 00 ... .....
```

- (rubbout) aborts long typeout

-G0, stop DDT, debug session complete



**CP/M 2.2 INTERFACE GUIDE**

## COPYRIGHT

Copyright (c) 1980 by Exidy Systems, Inc. All rights reserved. No part of this publication may be reproduced, transmitted, transcribed, stored in a retrieval system, or translated into any language, in any form or by any means, electronic, mechanical, magnetic, optical, chemical, manual, or otherwise, without the prior written permission of Exidy Systems, Inc., 1234 Elko Drive, Sunnyvale, California 94086.

Since this manual is tutorial in nature, permission is granted to reproduce or abstract the example procedures and sample programs for the purposes of inclusion within the reader's programs.

## DISCLAIMER

Exidy Systems, Inc. makes no representations or warranties with respect to the contents hereof and specifically disclaims any implied warranties of merchantability or fitness for any particular purpose. Further, Exidy Systems, Inc. reserves the right to revise this publication and to make changes from time to time in the content hereof without obligation of Exidy Systems, Inc. to notify any person of such revision or changes.

## TRADEMARKS

CP/M is a registered trademark of Digital Research.

**CP/M 2.2 INTERFACE GUIDE**

## COPYRIGHT

Copyright (c) 1980 by Exidy Systems, Inc. All rights reserved. No part of this publication may be reproduced, transmitted, transcribed, stored in a retrieval system, or translated into any language, in any form or by any means, electronic, mechanical, magnetic, optical, chemical, manual, or otherwise, without the prior written permission of Exidy Systems, Inc., 1234 Elko Drive, Sunnyvale, California 94086.

Since this manual is tutorial in nature, permission is granted to reproduce or abstract the example procedures and sample programs for the purposes of inclusion within the reader's programs.

## DISCLAIMER

Exidy Systems, Inc. makes no representations or warranties with respect to the contents hereof and specifically disclaims any implied warranties of merchantability or fitness for any particular purpose. Further, Exidy Systems, Inc. reserves the right to revise this publication and to make changes from time to time in the content hereof without obligation of Exidy Systems, Inc. to notify any person of such revision or changes.

## TRADEMARKS

CP/M is a registered trademark of Digital Research.

## Table Of Contents

### CP/M 2.2 Interface Guide

1.	Introduction.....	131
2.	Operating System Call Conventions.....	133
3.	A Sample File-To-File Copy Program.....	159
4.	A Sample File Dump Utility.....	164
5.	A Sample Random Access Program.....	167
6.	System Function Summary.....	176





## 1. INTRODUCTION.

This manual describes CP/M, release 2, system organization including the structure of memory and system entry points. The intention is to provide the necessary information required to write programs which operate under CP/M, and which use the peripheral and disk I/O facilities of the system.

CP/M is logically divided into four parts, called the Basic I/O System (BIOS), the Basic Disk Operating System (BDOS), the Console command processor (CCP), and the Transient Program Area (TPA). The BIOS is a hardware-dependent module which defines the exact low level interface to a particular computer system which is necessary for peripheral device I/O. Although a standard BIOS is supplied by Digital Research, explicit instructions are provided for field reconfiguration of the BIOS to match nearly any hardware environment (see the Digital Research manual entitled "CP/M Alteration Guide"). The BIOS and BDOS are logically combined into a single module with a common entry point, and referred to as the FDOS. The CCP is a distinct program which uses the FDOS to provide a human-oriented interface to the information which is cataloged on the backup storage device. The TPA is an area of memory (i.e., the portion which is not used by the FDOS and CCP) where various non-resident operating system commands and user programs are executed. The lower portion of memory is reserved for system information and is detailed later sections. Memory organization of the CP/M system is shown below:

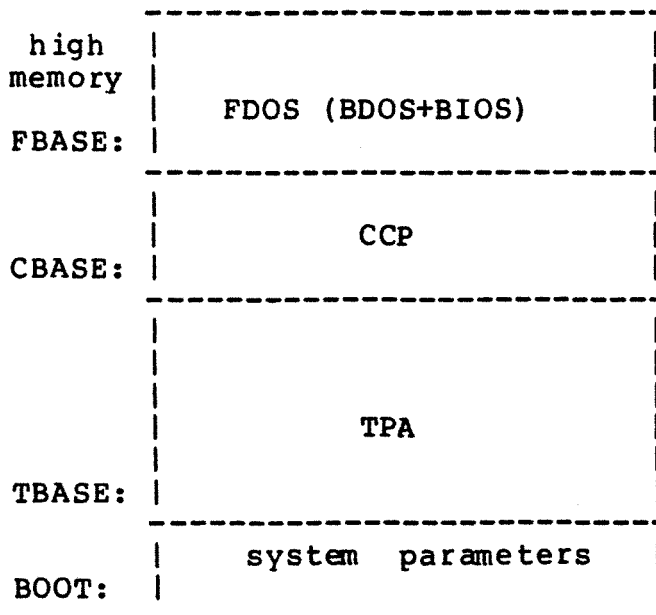

The exact memory addresses corresponding to BOOT, TBASE, CBASE, and FBASE vary from version to version, and are described fully in the "CP/M Alteration Guide." All standard CP/M versions, however, assume BOOT = 0000H, which is the base of random access memory. The machine code found at location BOOT performs a system "warm start" which loads and initializes the programs and variables necessary to return control to the CCP. Thus, transient programs need only jump to location BOOT

(All Information Contained Herein is Proprietary to Digital Research.)

to return control to CP/M at the command level. Further, the standard versions assume TBASE = BOOT+0100H which is normally location 0100H. The principal entry point to the FDOS is at location BOOT+0005H (normally 0005H) where a jump to FBASE is found. The address field at BOOT+0006H (normally 0006H) contains the value of FBASE and can be used to determine the size of available memory, assuming the CCP is being overlaid by a transient program.

Transient programs are loaded into the TPA and executed as follows. The operator communicates with the CCP by typing command lines following each prompt. Each command line takes one of the forms:

```
command
command file1
command file1 file2
```

where "command" is either a built-in function such as DIR or TYPE, or the name of a transient command or program. If the command is a built-in function of CP/M, it is executed immediately. Otherwise, the CCP searches the currently addressed disk for a file by the name

command.COM

If the file is found, it is assumed to be a memory image of a program which executes in the TPA, and thus implicitly originates at TBASE in memory. The CCP loads the COM file from the disk into memory starting at TBASE and possibly extending up to CBASE.

If the command is followed by one or two file specifications, the CCP prepares one or two file control block (FCB) names in the system parameter area. These optional FCB's are in the form necessary to access files through the FDOS, and are described in the next section.

The transient program receives control from the CCP and begins execution, perhaps using the I/O facilities of the FDOS. The transient program is "called" from the CCP, and thus can simply return to the CCP upon completion of its processing, or can jump to BOOT to pass control back to CP/M. In the first case, the transient program must not use memory above CBASE, while in the latter case, memory up through FBASE-1 is free.

The transient program may use the CP/M I/O facilities to communicate with the operator's console and peripheral devices, including the disk subsystem. The I/O system is accessed by passing a "function number" and an "information address" to CP/M through the FDOS entry point at BOOT+0005H. In the case of a disk read, for example, the transient program sends the number corresponding to a disk read, along with the address of an FCB to the CP/M FDOS. The FDOS, in turn, performs the operation and returns with either a disk read completion indication or an error number indicating that the disk read was unsuccessful. The function numbers and error indicators are given in below.

## 2. OPERATING SYSTEM CALL CONVENTIONS.

The purpose of this section is to provide detailed information for performing direct operating system calls from user programs. Many of the functions listed below, however, are more simply accessed through the I/O macro library provided with the MAC macro assembler, and listed in the Digital Research manual entitled "MAC Macro Assembler: Language Manual and Applications Guide."

CP/M facilities which are available for access by transient programs fall into two general categories: simple device I/O, and disk file I/O. The simple device operations include:

- Read a Console Character
- Write a Console Character
- Read a Sequential Tape Character
- Write a Sequential Tape Character
- Write a List Device Character
- Get or Set I/O Status
- Print Console Buffer
- Read Console Buffer
- Interrogate Console Ready

The FDOS operations which perform disk Input/Output are

- Disk System Reset
- Drive Selection
- File Creation
- File Open
- File Close
- Directory Search
- File Delete
- File Rename
- Random or Sequential Read
- Random or Sequential Write
- Interrogate Available Disks
- Interrogate Selected Disk
- Set DMA Address
- Set/Reset File Indicators

As mentioned above, access to the FDOS functions is accomplished by passing a function number and information address through the primary entry point at location `BOOT+0005H`. In general, the function number is passed in register C with the information address in the double byte pair DE. Single byte values are returned in register A, with double byte values returned in HL (a zero value is returned when the function number is out of range). For reasons of compatibility, register A = L and register B = H upon return in all cases. Note that the register passing conventions of CP/M agree with those of Intel's PL/M systems programming language. The list of CP/M function numbers is given below.

(All Information Contained Herein is Proprietary to Digital Research.)

0	System Reset	19	Delete File
1	Console Input	20	Read Sequential
2	Console Output	21	Write Sequential
3	Reader Input	22	Make File
4	Punch Output	23	Rename File
5	List Output	24	Return Login Vector
6	Direct Console I/O	25	Return Current Disk
7	Get I/O Byte	26	Set DMA Address
8	Set I/O Byte	27	Get Addr(Alloc)
9	Print String	28	Write Protect Disk
10	Read Console Buffer	29	Get R/O Vector
11	Get Console Status	30	Set File Attributes
12	Return Version Number	31	Get Addr(Disk Parms)
13	Reset Disk System	32	Set/Get User Code
14	Select Disk	33	Read Random
15	Open File	34	Write Random
16	Close File	35	Compute File Size
17	Search for First	36	Set Random Record
18	Search for Next		

(Functions 28 and 32 should be avoided in application programs to maintain upward compatibility with MP/M.)

Upon entry to a transient program, the CCP leaves the stack pointer set to an eight level stack area with the CCP return address pushed onto the stack, leaving seven levels before overflow occurs. Although this stack is usually not used by a transient program (i.e., most transients return to the CCP though a jump to location 0000H), it is sufficiently large to make CP/M system calls since the FDOS switches to a local stack at system entry. The following assembly language program segment, for example, reads characters continuously until an asterisk is encountered, at which time control returns to the CCP (assuming a standard CP/M system with BOOT = 0000H):

```

BDOS    EQU    0005H    ;STANDARD CP/M ENTRY
CONIN   EQU    1       ;CONSOLE INPUT FUNCTION
;
NEXTC:  ORG    0100H    ;BASE OF TPA
        MVI    C,CONIN ;READ NEXT CHARACTER
        CALL   BDOS    ;RETURN CHARACTER IN <A>
        CPI    '*'     ;END OF PROCESSING?
        JNZ    NEXTC   ;LOOP IF NOT
        RET                     ;RETURN TO CCP
        END

```

CP/M implements a named file structure on each disk, providing a logical organization which allows any particular file to contain any number of records from completely empty, to the full capacity of the drive. Each drive is logically distinct with a disk directory and file data area. The disk file names are in three parts: the drive select code, the file name consisting of one to eight non-blank characters, and the file type consisting of zero to three non-blank characters. The file type names the generic category of a particular file, while the file name distinguishes individual files in each category. The file types listed below name a few generic categories

(All Information Contained Herein is Proprietary to Digital Research.)

which have been established, although they are generally arbitrary:

ASM	Assembler Source	PLI	PL/I Source File
PRN	Printer Listing	REL	Relocatable Module
HEX	Hex Machine Code	TEX	TEX Formatter Source
BAS	Basic Source File	BAK	ED Source Backup
INT	Intermediate Code	SYM	SID Symbol File
COM	CCP Command File	\$\$\$	Temporary File

Source files are treated as a sequence of ASCII characters, where each "line" of the source file is followed by a carriage-return line-feed sequence (0DH followed by 0AH). Thus one 128 byte CP/M record could contain several lines of source text. The end of an ASCII file is denoted by a control-Z character (1AH) or a real end of file, returned by the CP/M read operation. Control-Z characters embedded within machine code files (e.g., COM files) are ignored, however, and the end of file condition returned by CP/M is used to terminate read operations.

Files in CP/M can be thought of as a sequence of up to 65536 records of 128 bytes each, numbered from 0 through 65535, thus allowing a maximum of 8 megabytes per file. Note, however, that although the records may be considered logically contiguous, they may not be physically contiguous in the disk data area. Internally, all files are broken into 16K byte segments called logical extents, so that counters are easily maintained as 8-bit values. Although the decomposition into extents is discussed in the paragraphs which follow, they are of no particular consequence to the programmer since each extent is automatically accessed in both sequential and random access modes.

In the file operations starting with function number 15, DE usually addresses a file control block (FCB). Transient programs often use the default file control block area reserved by CP/M at location BOOT+005CH (normally 005CH) for simple file operations. The basic unit of file information is a 128 byte record used for all file operations, thus a default location for disk I/O is provided by CP/M at location BOOT+0080H (normally 0080H) which is the initial default DMA address (see function 26). All directory operations take place in a reserved area which does not affect write buffers as was the case in release 1, with the exception of Search First and Search Next, where compatibility is required.

The File Control Block (FCB) data area consists of a sequence of 33 bytes for sequential access and a series of 36 bytes in the case that the file is accessed randomly. The default file control block normally located at 005CH can be used for random access files, since the three bytes starting at BOOT+007DH are available for this purpose. The FCB format is shown with the following fields:

(All Information Contained Herein is Proprietary to Digital Research.)

-----  
|dr|f1|f2|/ /|f8|t1|t2|t3|ex|s1|s2|rc|d0|/ /|dn|cr|r0|r1|r2|  
-----

00 01 02 ... 08 09 10 11 12 13 14 15 16 ... 31 32 33 34 35

where

dr drive code (0 - 16)  
0 => use default drive for file  
1 => auto disk select drive A,  
2 => auto disk select drive B,  
...  
16=> auto disk select drive P.

f1...f8 contain the file name in ASCII upper case, with high bit = 0

t1,t2,t3 contain the file type in ASCII upper case, with high bit = 0  
t1', t2', and t3' denote the bit of these positions,  
t1' = 1 => Read/Only file,  
t2' = 1 => SYS file, no DIR list

ex contains the current extent number, normally set to 00 by the user, but in range 0 - 31 during file I/O

s1 reserved for internal system use

s2 reserved for internal system use, set to zero on call to OPEN, MAKE, SEARCH

rc record count for extent "ex," takes on values from 0 - 128

d0...dn filled-in by CP/M, reserved for system use

cr current record to read or write in a sequential file operation, normally set to zero by user

r0,r1,r2 optional random record number in the range 0-65535, with overflow to r2, r0,r1 constitute a 16-bit value with low byte r0, and high byte r1

Each file being accessed through CP/M must have a corresponding FCB which provides the name and allocation information for all subsequent file operations. When accessing files, it is the programmer's responsibility to fill the lower sixteen bytes of the FCB and initialize the "cr" field. Normally, bytes 1 through 11 are set to the ASCII character values for the file name and file type, while all other fields are zero.

(All Information Contained Herein is Proprietary to Digital Research.)

FCB's are stored in a directory area of the disk, and are brought into central memory before proceeding with file operations (see the OPEN and MAKE functions). The memory copy of the FCB is updated as file operations take place and later recorded permanently on disk at the termination of the file operation (see the CLOSE command).

The CCP constructs the first sixteen bytes of two optional FCB's for a transient by scanning the remainder of the line following the transient name, denoted by "file1" and "file2" in the prototype command line described above, with unspecified fields set to ASCII blanks. The first FCB is constructed at location BOOT+005CH, and can be used as-is for subsequent file operations. The second FCB occupies the d0 ... dn portion of the first FCB, and must be moved to another area of memory before use. If, for example, the operator types

```
PROGNAME B:X.ZOT Y.ZAP
```

the file PROGNAME.COM is loaded into the TPA, and the default FCB at BOOT+005CH is initialized to drive code 2, file name "X" and file type "ZOT". The second drive code takes the default value 0, which is placed at BOOT+006CH, with the file name "Y" placed into location BOOT+006DH and file type "ZAP" located 8 bytes later at BOOT+0075H. All remaining fields through "cr" are set to zero. Note again that it is the programmer's responsibility to move this second file name and type to another area, usually a separate file control block, before opening the file which begins at BOOT+005CH, due to the fact that the open operation will overwrite the second name and type.

If no file names are specified in the original command, then the fields beginning at BOOT+005DH and BOOT+006DH contain blanks. In all cases, the CCP translates lower case alphabetic to upper case to be consistent with the CP/M file naming conventions.

As an added convenience, the default buffer area at location BOOT+0080H is initialized to the command line tail typed by the operator following the program name. The first position contains the number of characters, with the characters themselves following the character count. Given the above command line, the area beginning at BOOT+0080H is initialized as follows:

```
BOOT+0080H:
+00 +01 +02 +03 +04 +05 +06 +07 +08 +09 +10 +11 +12 +13 +14
14 " " "B" ":" "X" "." "Z" "O" "T" " " "Y" "." "Z" "A" "P"
```

where the characters are translated to upper case ASCII with uninitialized memory following the last valid character. Again, it is the responsibility of the programmer to extract the information from this buffer before any file operations are performed, unless the default DMA address is explicitly changed.

The individual functions are described in detail in the pages which follow.

```

*****
*
* FUNCTION 0: System Reset
*
*****
* Entry Parameters:
* Register C: 00H
*****

```

The system reset function returns control to the CP/M operating system at the CCP level. The CCP re-initializes the disk subsystem by selecting and logging-in disk drive A. This function has exactly the same effect as a jump to location BOOT.

```

*****
*
* FUNCTION 1: CONSOLE INPUT
*
*****
* Entry Parameters:
* Register C: 01H
*
* Returned Value:
* Register A: ASCII Character
*****

```

The console input function reads the next console character to register A. Graphic characters, along with carriage return, line feed, and backspace (ctl-H) are echoed to the console. Tab characters (ctl-I) are expanded in columns of eight characters. A check is made for start/stop scroll (ctl-S) and start/stop printer echo (ctl-P). The FDOS does not return to the calling program until a character has been typed, thus suspending execution if a character is not ready.

```

*****
*
* FUNCTION 2: CONSOLE OUTPUT
*
*****
* Entry Parameters:
* Register C: 02H
* Register E: ASCII Character
*
*****

```

The ASCII character from register E is sent to the console device. Similar to function 1, tabs are expanded and checks are made for start/stop scroll and printer echo.



```

*****
*
* FUNCTION 3: READER INPUT
*
*****
* Entry Parameters:
*   Register C: 03H
*
* Returned Value:
*   Register A: ASCII Character
*****

```

The Reader Input function reads the next character from the logical reader into register A (see the IOBYTE definition in the "CP/M Alteration Guide"). Control does not return until the character has been read.

```

*****
*
* FUNCTION 4: PUNCH OUTPUT
*
*****
* Entry Parameters:
*   Register C: 04H
*   Register E: ASCII Character
*
*****

```

The Punch Output function sends the character from register E to the logical punch device.

```

*****
*
* FUNCTION 5: LIST OUTPUT
*
*****
* Entry Parameters:
*   Register C: 05H
*   Register E: ASCII Character
*
*****

```

The List Output function sends the ASCII character in register E to the logical listing device.

```

*****
*
* FUNCTION 6: DIRECT CONSOLE I/O *
*
*****
* Entry Parameters: *
* Register C: 06H *
* Register E: 0FFH (input) or *
* char (output) *
*
* Returned Value: *
* Register A: char or status *
* (no value) *
*****

```

Direct console I/O is supported under CP/M for those specialized applications where unadorned console input and output is required. Use of this function should, in general, be avoided since it bypasses all of CP/M's normal control character functions (e.g., control-S and control-P). Programs which perform direct I/O through the BIOS under previous releases of CP/M, however, should be changed to use direct I/O under BDOS so that they can be fully supported under future releases of MP/M and CP/M.

Upon entry to function 6, register E either contains hexadecimal FF, denoting a console input request, or register E contains an ASCII character. If the input value is FF, then function 6 returns A = 00 if no character is ready, otherwise A contains the next console input character.

If the input value in E is not FF, then function 6 assumes that E contains a valid ASCII character which is sent to the console.

```

*****
*
* FUNCTION 7: GET I/O BYTE
*
*****
* Entry Parameters:
*   Register C: 07H
*
* Returned Value:
*   Register A: I/O Byte Value
*****

```

The Get I/O Byte function returns the current value of IOBYTE in register A. See the "CP/M Alteration Guide" for IOBYTE definition.

```

*****
*
* FUNCTION 8: SET I/O BYTE
*
*****
* Entry Parameters:
*   Register C: 08H
*   Register E: I/O Byte Value
*
*****

```

The Set I/O Byte function changes the system IOBYTE value to that given in register E.

```

*****
*
* FUNCTION 9: PRINT STRING
*
*****
* Entry Parameters:
*   Register C: 09H
*   Registers DE: String Address
*
*****

```

The Print String function sends the character string stored in memory at the location given by DE to the console device, until a "\$" is encountered in the string. Tabs are expanded as in function 2, and checks are made for start/stop scroll and printer echo.

```

*****
*
* FUNCTION 10: READ CONSOLE BUFFER *
*
*****
* Entry Parameters: *
* Register C: 0AH *
* Registers DE: Buffer Address *
*
* Returned Value: *
* Console Characters in Buffer *
*****

```

The Read Buffer function reads a line of edited console input into a buffer addressed by registers DE. Console input is terminated when either the input buffer overflows. The Read Buffer takes the form:

```

DE: +0 +1 +2 +3 +4 +5 +6 +7 +8 . . . +n
-----
|mx|nc|c1|c2|c3|c4|c5|c6|c7| . . . |??|
-----

```

where "mx" is the maximum number of characters which the buffer will hold (1 to 255), "nc" is the number of characters read (set by FDOS upon return), followed by the characters read from the console. if nc < mx, then uninitialized positions follow the last character, denoted by "??" in the above figure. A number of control functions are recognized during line editing:

- rub/del removes and echoes the last character
- ctl-C reboots when at the beginning of line
- ctl-E causes physical end of line
- ctl-H backspaces one character position
- ctl-J (line feed) terminates input line
- ctl-M (return) terminates input line
- ctl-R retypes the current line after new line
- ctl-U removes currnt line after new line
- ctl-X backspaces to beginning of current line

Note also that certain functions which return the carriage to the leftmost position (e.g., ctl-X) do so only to the column position where the prompt ended (in earlier releases, the carriage returned to the extreme left margin). This convention makes operator data input and line correction more legible.

```

*****
*
* FUNCTION 11: GET CONSOLE STATUS *
*
*****
* Entry Parameters: *
* Register C: 0BH *
*
* Returned Value: *
* Register A: Console Status *
*****

```

The Console Status function checks to see if a character has been typed at the console. If a character is ready, the value 0FFH is returned in register A. Otherwise a 00H value is returned.

```

*****
*
* FUNCTION 12: RETURN VERSION NUMBER *
*
*****
* Entry Parameters: *
* Register C: 0CH *
*
* Returned Value: *
* Registers HL: Version Number *
*****

```

Function 12 provides information which allows version independent programming. A two-byte value is returned, with H = 00 designating the CP/M release (H = 01 for MP/M), and L = 00 for all releases previous to 2.0. CP/M 2.0 returns a hexadecimal 20 in register L, with subsequent version 2 releases in the hexadecimal range 21, 22, through 2F. Using function 12, for example, you can write application programs which provide both sequential and random access functions, with random access disabled when operating under early releases of CP/M.

```

*****
*
* FUNCTION 13: RESET DISK SYSTEM
*
*****
* Entry Parameters:
* Register C: 0DH
*
*****

```

The Reset Disk Function is used to programmatically restore the file system to a reset state where all disks are set to read/write (see functions 28 and 29), only disk drive A is selected, and the default DMA address is reset to BOOT+0080H. This function can be used, for example, by an application program which requires a disk change without a system reboot.

```

*****
*
* FUNCTION 14: SELECT DISK
*
*****
* Entry Parameters:
* Register C: 0EH
* Register E: Selected Disk
*
*****

```

The Select Disk function designates the disk drive named in register E as the default disk for subsequent file operations, with E = 0 for drive A, 1 for drive B, and so-forth through 15 corresponding to drive P in a full sixteen drive system. The drive is placed in an "on-line" status which, in particular, activates its directory until the next cold start, warm start, or disk system reset operation. If the disk media is changed while it is on-line, the drive automatically goes to a read/only status in a standard CP/M environment (see function 28). FCB's which specify drive code zero (dr = 00H) automatically reference the currently selected default drive. Drive code values between 1 and 16, however, ignore the selected default drive and directly reference drives A through P.

```

*****
*
* FUNCTION 15: OPEN FILE
*
*****
* Entry Parameters:
* Register C: 0FH
* Registers DE: FCB Address
*
* Returned Value:
* Register A: Directory Code
*****

```

The Open File operation is used to activate a file which currently exists in the disk directory for the currently active user number. The FDOS scans the referenced disk directory for a match in positions 1 through 14 of the FCB referenced by DE (byte s1 is automatically zeroed), where an ASCII question mark (3FH) matches any directory character in any of these positions. Normally, no question marks are included and, further, bytes "ex" and "s2" of the FCB are zero.

If a directory element is matched, the relevant directory information is copied into bytes d0 through dn of the FCB, thus allowing access to the files through subsequent read and write operations. Note that an existing file must not be accessed until a successful open operation is completed. Upon return, the open function returns a "directory code" with the value 0 through 3 if the open was successful, or 0FFH (255 decimal) if the file cannot be found. If question marks occur in the FCB then the first matching FCB is activated. Note that the current record ("cr") must be zeroed by the program if the file is to be accessed sequentially from the first record.

```

*****
*
* FUNCTION 16: CLOSE FILE
*
*****
* Entry Parameters:
*   Register C: 10H
*   Registers DE: FCB Address
*
* Returned Value:
*   Register A: Directory Code
*****

```

The Close File function performs the inverse of the open file function. Given that the FCB addressed by DE has been previously activated through an open or make function (see functions 15 and 22), the close function permanently records the new FCB in the referenced disk directory. The FCB matching process for the close is identical to the open function. The directory code returned for a successful close operation is 0, 1, 2, or 3, while a 0FFH (255 decimal) is returned if the file name cannot be found in the directory. A file need not be closed if only read operations have taken place. If write operations have occurred, however, the close operation is necessary to permanently record the new directory information.



```

*****
*
* FUNCTION 17: SEARCH FOR FIRST *
*
*****
* Entry Parameters: *
* Register C: 11H *
* Registers DE: FCB Address *
*
* Returned Value: *
* Register A: Directory Code *
*****

```

Search First scans the directory for a match with the file given by the FCB addressed by DE. The value 255 (hexadecimal FF) is returned if the file is not found, otherwise 0, 1, 2, or 3 is returned indicating the file is present. In the case that the file is found, the current DMA address is filled with the record containing the directory entry, and the relative starting position is A \* 32 (i.e., rotate the A register left 5 bits, or ADD A five times). Although not normally required for application programs, the directory information can be extracted from the buffer at this position.

An ASCII question mark (63 decimal, 3F hexadecimal) in any position from "fl" through "ex" matches the corresponding field of any directory entry on the default or auto-selected disk drive. If the "dr" field contains an ASCII question mark, then the auto disk select function is disabled, the default disk is searched, with the search function returning any matched entry, allocated or free, belonging to any user number. This latter function is not normally used by application programs, but does allow complete flexibility to scan all current directory values. If the "dr" field is not a question mark, the "s2" byte is automatically zeroed.

```

*****
*
* FUNCTION 18: SEARCH FOR NEXT *
*
*****
* Entry Parameters: *
* Register C: 12H *
*
* Returned Value: *
* Register A: Directory Code *
*****

```

The Search Next function is similar to the Search First function, except that the directory scan continues from the last matched entry. Similar to function 17, function 18 returns the decimal value 255 in A when no more directory items match.

(All Information Contained Herein is Proprietary to Digital Research.)

```

*****
*
* FUNCTION 19: DELETE FILE
*
*****
* Entry Parameters:
* Register C: 13H
* Registers DE: FCB Address
*
* Returned Value:
* Register A: Directory Code
*****

```

The Delete File function removes files which match the FCB addressed by DE. The filename and type may contain ambiguous references (i.e., question marks in various positions), but the drive select code cannot be ambiguous, as in the Search and Search Next functions.

Function 19 returns a decimal 255 if the referenced file or files cannot be found, otherwise a value in the range 0 to 3 is returned.

```

*****
*
* FUNCTION 20: READ SEQUENTIAL
*
*****
* Entry Parameters:
* Register C: 14H
* Registers DE: FCB Address
*
* Returned Value:
* Register A: Directory Code
*****

```

Given that the FCB addressed by DE has been activated through an open or make function (numbers 15 and 22), the Read Sequential function reads the next 128 byte record from the file into memory at the current DMA address. The record is read from position "cr" of the extent, and the "cr" field is automatically incremented to the next record position. If the "cr" field overflows then the next logical extent is automatically opened and the "cr" field is reset to zero in preparation for the next read operation. The value 00H is returned in the A register if the read operation was successful, while a non-zero value is returned if no data exists at the next record position (e.g., end of file occurs).

```

*
* FUNCTION 21: WRITE SEQUENTIAL
*
*****
* Entry Parameters:
* Register C: 15H
* Registers DE: FCB Address
*
* Returned Value:
* Register A: Directory Code
*****

```

Given that the FCB addressed by DE has been activated through an open or make function (numbers 15 and 22), the Write Sequential function writes the 128 byte data record at the current DMA address to the file named by the FCB. the record is placed at position "cr" of the file, and the "cr" field is automatically incremented to the next record position. If the "cr" field overflows then the next logical extent is automatically opened and the "cr" field is reset to zero in preparation for the next write operation. Write operations can take place into an existing file, in which case newly written records overlay those which already exist in the file. Register A = 00H upon return from a successful write operation, while a non-zero value indicates an unsuccessful write due to a full disk.

```

*****
*
* FUNCTION 22: MAKE FILE
*
*****
* Entry Parameters:
* Register C: 16H
* Registers DE: FCB Address
*
* Returned Value:
* Register A: Directory Code
*****

```

The Make File operation is similar to the open file operation except that the FCB must name a file which does not exist in the currently referenced disk directory (i.e., the one named explicitly by a non-zero "dr" code, or the default disk if "dr" is zero). The FDOS creates the file and initializes both the directory and main memory value to an empty file. The programmer must ensure that no duplicate file names occur, and a preceding delete operation is sufficient if there is any possibility of duplication. Upon return, register A = 0, 1, 2, or 3 if the operation was successful and 0FFH (255 decimal) if no more directory space is available. The make function has the side-effect of activating the FCB and thus a subsequent open is not necessary.

(All Information Contained Herein is Proprietary to Digital Research.)

```

*****
*
* FUNCTION 23: RENAME FILE
*
*****
* Entry Parameters:
*   Register C: 17H
*   Registers DE: FCB Address
*
* Returned Value:
*   Register A: Directory Code
*****

```

The Rename function uses the FCB addressed by DE to change all occurrences of the file named in the first 16 bytes to the file named in the second 16 bytes. The drive code "dr" at position 0 is used to select the drive, while the drive code for the new file name at position 16 of the FCB is assumed to be zero. Upon return, register A is set to a value between 0 and 3 if the rename was successful, and 0FFH (255 decimal) if the first file name could not be found in the directory scan.

```

*****
*
* FUNCTION 24: RETURN LOGIN VECTOR
*
*****
* Entry Parameters:
*   Register C: 18H
*
* Returned Value:
*   Registers HL: Login Vector
*****

```

The login vector value returned by CP/M is a 16-bit value in HL, where the least significant bit of L corresponds to the first drive A, and the high order bit of H corresponds to the sixteenth drive, labelled P. A "0" bit indicates that the drive is not on-line, while a "1" bit marks an drive that is actively on-line due to an explicit disk drive selection, or an implicit drive select caused by a file operation which specified a non-zero "dr" field. Note that compatibility is maintained with earlier releases, since registers A and L contain the same values upon return.

```

*****
*
* FUNCTION 25: RETURN CURRENT DISK *
*
*****
* Entry Parameters: *
* Register C: 19H *
*
* Returned Value: *
* Register A: Current Disk *
*****

```

Function 25 returns the currently selected default disk number in register A. The disk numbers range from 0 through 15 corresponding to drives A through P.

```

*****
*
* FUNCTION 26: SET DMA ADDRESS *
*
*****
* Entry Parameters: *
* Register C: 1AH *
* Registers DE: DMA Address *
*
*****

```

"DMA" is an acronym for Direct Memory Address, which is often used in connection with disk controllers which directly access the memory of the mainframe computer to transfer data to and from the disk subsystem. Although many computer systems use non-DMA access (i.e., the data is transferred through programmed I/O operations), the DMA address has, in CP/M, come to mean the address at which the 128 byte data record resides before a disk write and after a disk read. Upon cold start, warm start, or disk system reset, the DMA address is automatically set to BOOT+0080H. The Set DMA function, however, can be used to change this default value to address another area of memory where the data records reside. Thus, the DMA address becomes the value specified by DE until it is changed by a subsequent Set DMA function, cold start, warm start, or disk system reset.

```

*****
*
* FUNCTION 27: GET ADDR(ALLOC)
*
*****
* Entry Parameters:
* Register C: 1BH
*
* Returned Value:
* Registers HL: ALLOC Address
*****

```

An "allocation vector" is maintained in main memory for each on-line disk drive. Various system programs use the information provided by the allocation vector to determine the amount of remaining storage (see the STAT program). Function 27 returns the base address of the allocation vector for the currently selected disk drive. The allocation information may, however, be invalid if the selected disk has been marked read/only. Although this function is not normally used by application programs, additional details of the allocation vector are found in the "CP/M Alteration Guide."

```

*****
*
* FUNCTION 28: WRITE PROTECT DISK
*
*****
* Entry Parameters:
* Register C: 1CH
*
*****

```

The disk write protect function provides temporary write protection for the currently selected disk. Any attempt to write to the disk, before the next cold or warm start operation produces the message

Bdos Err on d: R/O

```

*****
*
* FUNCTION 29: GET READ/ONLY VECTOR *
*
*****
* Entry Parameters: *
* Register C: 1DH *
*
* Returned Value: *
* Registers HL: R/O Vector Value*
*****

```

Function 29 returns a bit vector in register pair HL which indicates drives which have the temporary read/only bit set. Similar to function 24, the least significant bit corresponds to drive A, while the most significant bit corresponds to drive P. The R/O bit is set either by an explicit call to function 28, or by the automatic software mechanisms within CP/M which detect changed disks.

```

*****
*
* FUNCTION 30: SET FILE ATTRIBUTES *
*
*****
* Entry Parameters: *
* Register C: 1EH *
* Registers DE: FCB Address *
*
* Returned Value: *
* Register A: Directory Code *
*****

```

The Set File Attributes function allows programmatic manipulation of permanent indicators attached to files. In particular, the R/O and System attributes (t1' and t2') can be set or reset. The DE pair addresses an unambiguous file name with the appropriate attributes set or reset. Function 30 searches for a match, and changes the matched directory entry to contain the selected indicators. Indicators f1' through f4' are not presently used, but may be useful for applications programs, since they are not involved in the matching process during file open and close operations. Indicators f5' through f8' and t3' are reserved for future system expansion.

```

*****
*
* FUNCTION 31: GET ADDR(DISK PARMS) *
*
*****
* Entry Parameters: *
* Register C: 1FH *
*
* Returned Value: *
* Registers HL: DPB Address *
*****

```

The address of the BIOS resident disk parameter block is returned in HL as a result of this function call. This address can be used for either of two purposes. First, the disk parameter values can be extracted for display and space computation purposes, or transient programs can dynamically change the values of current disk parameters when the disk environment changes, if required. Normally, application programs will not require this facility.

```

*****
*
* FUNCTION 32: SET/GET USER CODE *
*
*****
* Entry Parameters: *
* Register C: 20H *
* Register E: 0FFH (get) or *
* User Code (set) *
*
* Returned Value: *
* Register A: Current Code or *
* (no value) *
*****

```

An application program can change or interrogate the currently active user number by calling function 32. If register E = 0FFH, then the value of the current user number is returned in register A, where the value is in the range 0 to 31. If register E is not 0FFH, then the current user number is changed to the value of E (modulo 32).



```

*****
*
*   FUNCTION 33: READ RANDOM
*
*****
*   Entry Parameters:
*       Register C: 21H
*       Registers DE: FCB Address
*
*   Returned Value:
*       Register A: Return Code
*****

```

The Read Random function is similar to the sequential file read operation of previous releases, except that the read operation takes place at a particular record number, selected by the 24-bit value constructed from the three byte field following the FCB (byte positions r0 at 33, r1 at 34, and r2 at 35). Note that the sequence of 24 bits is stored with least significant byte first (r0), middle byte next (r1), and high byte last (r2). CP/M does not reference byte r2, except in computing the size of a file (function 35). Byte r2 must be zero, however, since a non-zero value indicates overflow past the end of file.

Thus, the r0,r1 byte pair is treated as a double-byte, or "word" value, which contains the record to read. This value ranges from 0 to 65535, providing access to any particular record of the 8 megabyte file. In order to process a file using random access, the base extent (extent 0) must first be opened. Although the base extent may or may not contain any allocated data, this ensures that the file is properly recorded in the directory, and is visible in DIR requests. The selected record number is then stored into the random record field (r0,r1), and the BDOS is called to read the record. Upon return from the call, register A either contains an error code, as listed below, or the value 00 indicating the operation was successful. In the latter case, the current DMA address contains the randomly accessed record. Note that contrary to the sequential read operation, the record number is not advanced. Thus, subsequent random read operations continue to read the same record.

Upon each random read operation, the logical extent and current record values are automatically set. Thus, the file can be sequentially read or written, starting from the current randomly accessed position. Note, however, that in this case, the last randomly read record will be re-read as you switch from random mode to sequential read, and the last record will be re-written as you switch to a sequential write operation. You can, of course, simply advance the random record position following each random read or write to obtain the effect of a sequential I/O operation.

Error codes returned in register A following a random read are listed below.

(All Information Contained Herein is Proprietary to Digital Research.)

- 01 reading unwritten data
- 02 (not returned in random mode)
- 03 cannot close current extent
- 04 seek to unwritten extent
- 05 (not returned in read mode)
- 06 seek past physical end of disk

Error code 01 and 04 occur when a random read operation accesses a data block which has not been previously written, or an extent which has not been created, which are equivalent conditions. Error 3 does not normally occur under proper system operation, but can be cleared by simply re-reading, or re-opening extent zero as long as the disk is not physically write protected. Error code 06 occurs whenever byte r2 is non-zero under the current 2.0 release. Normally, non-zero return codes can be treated as missing data, with zero return codes indicating operation complete.

```

*****
*
* FUNCTION 34: WRITE RANDOM
*
*****
* Entry Parameters:
*   Register C: 22H
*   Registers DE: FCB Address
*
* Returned Value:
*   Register A: Return Code
*****

```

The Write Random operation is initiated similar to the Read Random call, except that data is written to the disk from the current DMA address. Further, if the disk extent or data block which is the target of the write has not yet been allocated, the allocation is performed before the write operation continues. As in the Read Random operation, the random record number is not changed as a result of the write. The logical extent number and current record positions of the file control block are set to correspond to the random record which is being written. Again, sequential read or write operations can commence following a random write, with the notation that the currently addressed record is either read or rewritten again as the sequential operation begins. You can also simply advance the random record position following each write to get the effect of a sequential write operation. Note that in particular, reading or writing the last record of an extent in random mode does not cause an automatic extent switch as it does in sequential mode.

The error codes returned by a random write are identical to the random read operation with the addition of error code #5, which indicates that a new extent cannot be created due to directory overflow.

```

*****
*                                     *
*  FUNCTION 35: COMPUTE FILE SIZE    *
*                                     *
*****
*  Entry Parameters:                 *
*      Register C: 23H                *
*      Registers DE: FCB Address      *
*                                     *
*  Returned Value:                   *
*      Random Record Field Set       *
*****

```

When computing the size of a file, the DE register pair addresses an FCB in random mode format (bytes r0, r1, and r2 are present). The FCB contains an unambiguous file name which is used in the directory scan. Upon return, the random record bytes contain the "virtual" file size which is, in effect, the record address of the record following the end of the file. If, following a call to function 35, the high record byte r2 is 01, then the file contains the maximum record count 65536. Otherwise, bytes r0 and r1 constitute a 16-bit value (r0 is the least significant byte, as before) which is the file size.

Data can be appended to the end of an existing file by simply calling function 35 to set the random record position to the end of file, then performing a sequence of random writes starting at the preset record address.

The virtual size of a file corresponds to the physical size when the file is written sequentially. If, instead, the file was created in random mode and "holes" exist in the allocation, then the file may in fact contain fewer records than the size indicates. If, for example, only the last record of an eight megabyte file is written in random mode (i.e., record number 65535), then the virtual size is 65536 records, although only one block of data is actually allocated.

```

*****
*
*  FUNCTION 36: SET RANDOM RECORD  *
*
*****
*  Entry Parameters:              *
*    Register C: 24H              *
*    Registers DE: FCB Address    *
*
*  Returned Value:               *
*    Random Record Field Set     *
*****

```

The Set Random Record function causes the BDOS to automatically produce the random record position from a file which has been read or written sequentially to a particular point. The function can be useful in two ways.

First, it is often necessary to initially read and scan a sequential file to extract the positions of various "key" fields. As each key is encountered, function 36 is called to compute the random record position for the data corresponding to this key. If the data unit size is 128 bytes, the resulting record position is placed into a table with the key for later retrieval. After scanning the entire file and tabularizing the keys and their record numbers, you can move instantly to a particular keyed record by performing a random read using the corresponding random record number which was saved earlier. The scheme is easily generalized when variable record lengths are involved since the program need only store the buffer-relative byte position along with the key and record number in order to find the exact starting position of the keyed data at a later time.

A second use of function 36 occurs when switching from a sequential read or write over to random read or write. A file is sequentially accessed to a particular point in the file, function 36 is called which sets the record number, and subsequent random read and write operations continue from the selected point in the file.

### 3. A SAMPLE FILE-TO-FILE COPY PROGRAM.

The program shown below provides a relatively simple example of file operations. The program source file is created as COPY.ASM using the CP/M ED program and then assembled using ASM or MAC, resulting in a "HEX" file. The LOAD program is the used to produce a COPY.COM file which executes directly under the CCP. The program begins by setting the stack pointer to a local area, and then proceeds to move the second name from the default area at 006CH to a 33-byte file control block called DFCB. The DFCB is then prepared for file operations by clearing the current record field. At this point, the source and destination FCB's are ready for processing since the SFCB at 005CH is properly set-up by the CCP upon entry to the COPY program. That is, the first name is placed into the default fcb, with the proper fields zeroed, including the current record field at 007CH. The program continues by opening the source file, deleting any existing destination file, and then creating the destination file. If all this is successful, the program loops at the label COPY until each record has been read from the source file and placed into the destination file. Upon completion of the data transfer, the destination file is closed and the program returns to the CCP command level by jumping to BOOT.

```

;      sample file-to-file copy program
;
;      at the ccp level, the command
;
;      copy a:x.y b:u.v
;
;      copies the file named x.y from drive
;      a to a file named u.v on drive b.
;
0000 = boot      equ      0000h   ; system reboot
0005 = bdos      equ      0005h   ; bdos entry point
005c = fcbl      equ      005ch   ; first file name
005c = sfcbl     equ      fcbl    ; source fcb
006c = fcb2      equ      006ch   ; second file name
0080 = dbuff     equ      0080h   ; default buffer
0100 = tpa       equ      0100h   ; beginning of tpa
;
0009 = printf    equ      9       ; print buffer func#
000f = openf     equ      15      ; open file func#
0010 = closef    equ      16      ; close file func#
0013 = deletef   equ      19      ; delete file func#
0014 = readf     equ      20      ; sequential read
0015 = writef    equ      21      ; sequential write
0016 = makef     equ      22      ; make file func#
;
0100                org      tpa    ; beginning of tpa
0100 311b02         lxi      sp,stack; local stack
;
;      move second file name to dfcb
0103 0e10          mvi      c,16    ; half an fcb
```

(All Information Contained Herein is Proprietary to Digital Research.)

```

0105 116c00      lxi      d,fc b2 ; source of move
0108 21da01      lxi      h,dfcb ; destination fcb
010b 1a          mfc b:  ldax   d      ; source fcb
010c 13          inx     d      ; ready next
010d 77          mov     m,a    ; dest fcb
010e 23          inx     h      ; ready next
010f 0d          dcr     c      ; count 16...0
0110 c20b01      jnz     mfc b  ; loop 16 times
;
;
; name has been moved, zero cr
0113 af          xra     a      ; a = 00h
0114 32fa01      sta     dfcbcr ; current rec = 0
;
;
; source and destination fcb's ready
;
;
0117 115c00      lxi     d,sfcb ; source file
011a cd6901      call   open   ; error if 255
011d 118701      lxi     d,nofile; ready message
0120 3c          inr     a      ; 255 becomes 0
0121 cc6101      cz      finis ; done if no file
;
;
; source file open, prep destination
0124 11da01      lxi     d,dfcb ; destination
0127 cd7301      call   delete ; remove if present
;
;
012a 11da01      lxi     d,dfcb ; destination
012d cd8201      call   make   ; create the file
0130 119601      lxi     d,nodir; ready message
0133 3c          inr     a      ; 255 becomes 0
0134 cc6101      cz      finis ; done if no dir space
;
;
; source file open, dest file open
;
; copy until end of file on source
;
0137 115c00 copy:  lxi     d,sfcb ; source
013a cd7801      call   read   ; read next record
013d b7          ora     a      ; end of file?
013e c25101      jnz     eofile ; skip write if so
;
;
; not end of file, write the record
0141 11da01      lxi     d,dfcb ; destination
0144 cd7d01      call   write  ; write record
0147 11a901      lxi     d,space; ready message
014a b7          ora     a      ; 00 if write ok
014b c46101      cnz    finis ; end if so
014e c33701      jmp    copy   ; loop until eof
;
; eofile: ; end of file, close destination
0151 11da01      lxi     d,dfcb ; destination
0154 cd6e01      call   close  ; 255 if error
0157 21bb01      lxi     h,wrprot; ready message
015a 3c          inr     a      ; 255 becomes 00
015b cc6101      cz      finis ; shouldn't happen
;
;
; copy operation complete, end

```

```

015e 11cc01      lxi      d,normal; ready message
;
;finis: ; write message given by de, reboot
0161 0e09      mvi      c,printf
0163 cd0500     call     bdos ; write message
0166 c30000     jmp      boot ; reboot system
;
;      system interface subroutines
;      (all return directly from bdos)
;
0169 0e0f      open:   mvi      c,openf
016b c30500     jmp      bdos
;
016e 0e10      close:  mvi      c,closef
0170 c30500     jmp      bdos
;
0173 0e13      delete: mvi      c,deletf
0175 c30500     jmp      bdos
;
0178 0e14      read:   mvi      c,readf
017a c30500     jmp      bdos
;
017d 0e15      write: mvi      c,writf
017f c30500     jmp      bdos
;
0182 0e16      make:   mvi      c,makef
0184 c30500     jmp      bdos
;
;      console messages
0187 6e6f20fno: db      'no source file$'
0196 6e6f209no: db      'no directory space$'
01a9 6f7574fspa: db      'out of data space$'
01bb 7772695wrp: db      'write protected?$'
01cc 636f700nor: db      'copy complete$'
;
;      data areas
01da      dfcb:   ds      33 ; destination fcb
01fa =     dfcbcr equ    dfcb+32 ; current record
;
01fb      ds      32 ; 16 level stack
stack:
021b      end

```

Note that there are several simplifications in this particular program. First, there are no checks for invalid file names which could, for example, contain ambiguous references. This situation could be detected by scanning the 32 byte default area starting at location 005CH for ASCII question marks. A check should also be made to ensure that the file names have, in fact, been included (check locations 005DH and 006DH for non-blank ASCII characters). Finally, a check should be made to ensure that the source and destination file names are different. A speed improvement could be made by buffering more data on each read operation. One could, for example, determine

(All Information Contained Herein is Proprietary to Digital Research.)



the size of memory by fetching FBASE from location 0006H and use the entire remaining portion of memory for a data buffer. In this case, the programmer simply resets the DMA address to the next successive 128 byte area before each read. Upon writing to the destination file, the DMA address is reset to the beginning of the buffer and incremented by 128 bytes to the end as each record is transferred to the destination file.

#### 4. A SAMPLE FILE DUMP UTILITY.

The file dump program shown below is slightly more complex than the simple copy program given in the previous section. The dump program reads an input file, specified in the CCP command line, and displays the content of each record in hexadecimal format at the console. Note that the dump program saves the CCP's stack upon entry, resets the stack to a local area, and restores the CCP's stack before returning directly to the CCP. Thus, the dump program does not perform a warm start at the end of processing.

```

; DUMP program reads input file and displays hex data
;
0100          org      100h
0005 =       bdos     equ      0005h    ;dos entry point
0001 =       cons     equ      1        ;read console
0002 =       typef    equ      2        ;type function
0009 =       printf   equ      9        ;buffer print entry
000b =       brkf     equ      11       ;break key function (true if char
000f =       openf    equ      15       ;file open
0014 =       readf    equ      20       ;read function
;
005c =       fcb      equ      5ch      ;file control block address
0080 =       buff     equ      80h      ;input disk buffer address
;
;          non graphic characters
000d =       cr       equ      0dh      ;carriage return
000a =       lf       equ      0ah      ;line feed
;
;          file control block definitions
005c =       fcbdn    equ      fcb+0    ;disk name
005d =       fcbfn    equ      fcb+1    ;file name
0065 =       fcbft    equ      fcb+9    ;disk file type (3 characters)
0068 =       fcbrl    equ      fcb+12   ;file's current reel number
006b =       fcbrc    equ      fcb+15   ;file's record count (0 to 128)
007c =       fcbcr    equ      fcb+32   ;current (next) record number (0
007d =       fcbln    equ      fcb+33   ;fcb length
;
;          set up stack
0100 210000   lxi      h,0
0103 39       dad      sp
;
;          entry stack pointer in hl from the ccp
0104 221502   shld     oldsp
;
;          set sp to local stack area (restored at finis)
0107 315702   lxi      sp,stktop
;
;          read and print successive buffers
010a cdcl01   call     setup    ;set up input file
010d feff     cpi      255      ;255 if file not present
010f c21b01   jnz      openok   ;skip if open is ok
;
;          file not there, give error message and return
0112 11f301   lxi      d,opnmsg
0115 cd9c01   call     err
0118 c35101   jmp      finis    ;to return
;

```

```

openok: ;open operation ok, set buffer index to end
011b 3e80      mvi      a,80h
011d 321302    sta      ibp      ;set buffer pointer to 80h
;             hl contains next address to print
0120 210000    lxi      h,0      ;start with 0000
;
gloop:
0123 e5        push     h          ;save line position
0124 cda201    call    gnb        ;
0127 e1        pop     h          ;recall line position
0128 da5101    jc     finis      ;carry set by gnb if end file
012b 47        mov     b,a
;             print hex values
;             check for line fold
012c 7d        mov     a,l
012d e60f      ani     0fh        ;check low 4 bits
012f c24401    jnz     nonum
;             print line number
0132 cd7201    call    crlf
;
;             check for break key
0135 cd5901    call    break
;             accum lsb = 1 if character ready
0138 0f        rrc
;             ;into carry
0139 da5101    jc     finis      ;don't print any more
;
013c 7c        mov     a,h
013d cd8f01    call    phex
0140 7d        mov     a,l
0141 cd8f01    call    phex
nonum:
0144 23        inx     h          ;to next line number
0145 3e20      mvi     a,' '
0147 cd6501    call    pchar
014a 78        mov     a,b
014b cd8f01    call    phex
014e c32301    jmp     gloop
;
finis:
;             end of dump, return to ccp
;             (note that a jmp to 0000h reboots)
0151 cd7201    call    crlf
0154 2a1502    lhld   oldsp
0157 f9        sphl
;             stack pointer contains ccp's stack location
0158 c9        ret
;             ;to the ccp
;
;
;             subroutines
;
break: ;check break key (actually any key will do)
0159 e5d5c5    push h! push d! push b; environment saved
015c 0e0b      mvi     c,brkf
015e cd0500    call    bdos
0161 c1d1e1    pop b! pop d! pop h; environment restored

```

```

0164 c9          ret
;
pchar: ;print a character
0165 e5d5c5     push h! push d! push b; saved
0168 0e02       mvi      c,typef
016a 5f         mov      e,a
016b cd0500     call    bdos
016e c1d1e1     pop b! pop d! pop h; restored
0171 c9         ret
;
crlf:
0172 3e0d       mvi      a,cr
0174 cd6501     call    pchar
0177 3e0a       mvi      a,lf
0179 cd6501     call    pchar
017c c9         ret
;
;
pnib: ;print nibble in reg a
017d e60f       ani      0fh ;low 4 bits
017f fe0a       cpi      10
0181 d28901     jnc      pl0
; less than or equal to 9
0184 c630       adi      '0'
0186 c38b01     jmp     prn
;
; greater or equal to 10
0189 c637     pl0:    adi      'a' - 10
018b cd6501     prn:    call    pchar
018e c9         ret
;
;
phex: ;print hex char in reg a
018f f5         push    psw
0190 0f         rrc
0191 0f         rrc
0192 0f         rrc
0193 0f         rrc
0194 cd7d01     call    pnib ;print nibble
0197 f1         pop     psw
0198 cd7d01     call    pnib
019b c9         ret
;
;
err: ;print error message
; d,e addresses message ending with "$"
019c 0e09       mvi      c,printf ;print buffer function
019e cd0500     call    bdos
01a1 c9         ret
;
;
gnb: ;get next byte
01a2 3a1302     lda     ibp
01a5 fe80       cpi     80h
01a7 c2b301     jnz     g0
; read another buffer
;

```

```

;
01aa cdce01      call   diskr
01ad b7          ora    a      ;zero value if read ok
01ae cab301      jz     g0     ;for another byte
;
01b1 37          ;
01b2 c9          ;
;
;g0:            ;read the byte at buff+reg a
01b3 5f          mov    e,a     ;ls byte of buffer index
01b4 1600        mvi    d,0     ;double precision index to de
01b6 3c          inr    a      ;index=index+1
01b7 321302      sta    ibp     ;back to memory
;
;              ;pointer is incremented
;              ;save the current file address
01ba 218000      lxi    h,buff
01bd 19          dad    d
;
;              ;absolute character address is in hl
01be 7e          mov    a,m
;
;              ;byte is in the accumulator
01bf b7          ora    a      ;reset carry bit
01c0 c9          ret
;
;setup:         ;set up file
;              ;open the file for input
01c1 af          xra    a      ;zero to accum
01c2 327c00      sta    fcbr    ;clear current record
;
;              ;
01c5 115c00      lxi    d,fcbr
01c8 0e0f        mvi    c,openf
01ca cd0500      call   bdos
;
;              ;255 in accum if open error
01cd c9          ret
;
;diskr:         ;read disk file record
01ce e5d5c5      push  h! push d! push b
01d1 115c00      lxi    d,fcbr
01d4 0e14        mvi    c,readf
01d6 cd0500      call   bdos
01d9 c1d1e1      pop   b! pop d! pop h
01dc c9          ret
;
;              ;fixed message area
01dd 46494c0$signon: db    'file dump version 2.0$'
01f3 0d0a4e0$opnmsg: db    cr,lf,'no input file present on disk$'
;
;              ;variable area
0213            ibp:    ds    2      ;input buffer pointer
0215            oldsp: ds    2      ;entry sp value from ccp
;
;              ;stack area
0217            ds    64      ;reserve 32 level stack
;
;              ;
;stktop:
;
0257            end

```

## 5. A SAMPLE RANDOM ACCESS PROGRAM.

This manual is concluded with a rather extensive, but complete example of random access operation. The program listed below performs the simple function of reading or writing random records upon command from the terminal. Given that the program has been created, assembled, and placed into a file labelled RANDOM.COM, the CCP level command:

RANDOM X.DAT

starts the test program. The program looks for a file by the name X.DAT (in this particular case) and, if found, proceeds to prompt the console for input. If not found, the file is created before the prompt is given. Each prompt takes the form

next command?

and is followed by operator input, terminated by a carriage return. The input commands take the form

nW nR Q

where n is an integer value in the range 0 to 65535, and W, R, and Q are simple command characters corresponding to random write, random read, and quit processing, respectively. If the W command is issued, the RANDOM program issues the prompt

type data:

The operator then responds by typing up to 127 characters, followed by a carriage return. RANDOM then writes the character string into the X.DAT file at record n. If the R command is issued, RANDOM reads record number n and displays the string value at the console. If the Q command is issued, the X.DAT file is closed, and the program returns to the console command processor. In the interest of brevity, the only error message is

error, try again

The program begins with an initialization section where the input file is opened or created, followed by a continuous loop at the label "ready" where the individual commands are interpreted. The default file control block at 005CH and the default buffer at 0080H are used in all disk operations. The utility subroutines then follow, which contain the principal input line processor, called "readc." This particular program shows the elements of random access processing, and can be used as the basis for further program development.

```

;*****
;*
;* sample random access program for cp/m 2.0
;*
;*****
0100          org      100h      ;base of tpa
;
0000 =       reboot   equ      0000h  ;system reboot
0005 =       bdos     equ      0005h  ;bdos entry point
;
0001 =       coninp   equ      1       ;console input function
0002 =       conout   equ      2       ;console output function
0009 =       pstring  equ      9       ;print string until '$'
000a =       rstring  equ      10      ;read console buffer
000c =       version  equ      12      ;return version number
000f =       openf    equ      15      ;file open function
0010 =       closef   equ      16      ;close function
0016 =       makef    equ      22      ;make file function
0021 =       readr    equ      33      ;read random
0022 =       writer   equ      34      ;write random
;
005c =       fcb      equ      005ch   ;default file control block
007d =       ranrec   equ      fcb+33   ;random record position
007f =       ranovf   equ      fcb+35   ;high order (overflow) byte
0080 =       buff     equ      0080h   ;buffer address
;
000d =       cr       equ      0dh     ;carriage return
000a =       lf       equ      0ah     ;line feed
;
;*****
;*
;* load SP, set-up file for random access
;*
;*****
0100 31bc0    lxi      sp,stack
;
;          version 2.0?
0103 0e0c    mvi      c,version
0105 cd050    call     bdos
0108 fe20    cpi      20h      ;version 2.0 or better?
010a d2160    jnc      versok
;          bad version, message and go back
010d 111b0    lxi      d,badver
0110 cdda0    call     print
0113 c3000    jmp      reboot
;
versok:
;          correct version for random access
0116 0e0f    mvi      c,openf ;open default fcb
0118 115c0    lxi      d,fcbl
011b cd050    call     bdos
011e 3c      inr      a          ;err 255 becomes zero
011f c2370    jnz      ready
;
;          cannot open file, so create it

```

(All Information Contained Herein is Proprietary to Digital Research.)

```

0122 0e16          mvi      c,makef
0124 115c0        lxi      d,fcbl
0127 cd050        call     bdosl
012a 3c           inr      a          ;err 255 becomes zero
012b c2370        jnz     ready

;
;          cannot create file, directory full
012e 113a0        lxi      d,nospace
0131 cdda0        call     print
0134 c3000        jmp     reboot ;back to ccp

;
;*****
;*
;* loop back to "ready" after each command
;*
;*****
;
ready:
;          file is ready for processing
;
;          call     readcom ;read next command
0137 cde50
013a 227d0        shld    ranrec ;store input record#
013d 217f0        lxi     h,ranovf
0140 3600        mvi     m,0      ;clear high byte if set
0142 fe51        cpi     'Q'      ;quit?
0144 c2560        jnz     notq

;
;          quit processing, close file
0147 0e10        mvi     c,closef
0149 115c0        lxi     d,fcbl
014c cd050        call     bdosl
014f 3c           inr     a          ;err 255 becomes 0
0150 cab90        jz      error    ;error message, retry
0153 c3000        jmp     reboot ;back to ccp

;
;*****
;*
;* end of quit command, process write
;*
;*****
notq:
;          not the quit command, random write?
0156 fe57        cpi     'W'
0158 c2890        jnz     notw

;
;          this is a random write, fill buffer until cr
015b 114d0        lxi     d,datmsg
015e cdda0        call    print    ;data prompt
0161 0e7f        mvi     c,127    ;up to 127 characters
0163 21800        lxi     h,buff   ;destination
rloop: ;read next character to buff
0166 c5          push    b        ;save counter
0167 e5          push    h        ;next destination
0168 cdc20        call   getchr   ;character to a
016b e1          pop     h        ;restore counter

```



```

016c c1      pop      b      ;restore next to fill
016d fe0d   cpi      cr      ;end of line?
016f ca780  jz       erloop
;
0172 77     mov      m,a
0173 23     inx     h      ;next to fill
0174 0d     dcr     c      ;counter goes down
0175 c2660  jnz     rloop   ;end of buffer?
erloop:
;
0178 3600   mvi     m,0
;
;
; write the record to selected record number
017a 0e22   mvi     c,writer
017c 115c0  lxi     d,fcbl
017f cd050  call    bdos
0182 b7     ora     a      ;error code zero?
0183 c2b90  jnz     error   ;message if not
0186 c3370  jmp     ready   ;for another record
;
;*****
;*
;* end of write command, process read
;*
;*****
notw:
;
0189 fe52   cpi     'R'
018b c2b90  jnz     error   ;skip if not
;
;
; read random record
018e 0e21   mvi     c,readr
0190 115c0  lxi     d,fcbl
0193 cd050  call    bdos
0196 b7     ora     a      ;return code 00?
0197 c2b90  jnz     error
;
;
; read was successful, write to console
019a cdcf0   call    crlf   ;new line
019d 0e80   mvi     c,128  ;max 128 characters
019f 21800  lxi     h,buff ;next to get
wloop:
01a2 7e     mov     a,m    ;next character
01a3 23     inx     h    ;next to get
01a4 e67f   ani     7fh   ;mask parity
01a6 ca370  jz     ready  ;for another command if 00
01a9 c5     push    b    ;save counter
01aa e5     push    h    ;save next to get
01ab fe20   cpi     ' '   ;graphic?
01ad d4c80  cnc     putchr ;skip output if not
01b0 e1     pop     h
01b1 c1     pop     b
01b2 0d     dcr     c    ;count=count-1
01b3 c2a20  jnz     wloop
01b6 c3370  jmp     ready

```

(All Information Contained Herein is Proprietary to Digital Research.)

```

;
;*****
;*
;* end of read command, all errors end-up here
;*
;*****
;
error:
01b9 11590      lxi      d,errmsg
01bc cdda0      call     print
01bf c3370      jmp      ready
;
;*****
;*
;* utility subroutines for console i/o
;*
;*****
getchr:
;read next console character to a
01c2 0e01      mvi      c,coninp
01c4 cd050      call     bdos
01c7 c9        ret
;
putchr:
;write character from a to console
01c8 0e02      mvi      c,conout
01ca 5f        mov      e,a      ;character to send
01cb cd050      call     bdos      ;send character
01ce c9        ret
;
crlf:
;send carriage return line feed
01cf 3e0d      mvi      a,cr      ;carriage return
01d1 cdc80      call     putchr
01d4 3e0a      mvi      a,lf      ;line feed
01d6 cdc80      call     putchr
01d9 c9        ret
;
print:
;print the buffer addressed by de until $
01da d5        push     d
01db cdcf0      call     crlf
01de d1        pop      d      ;new line
01df 0e09      mvi      c,pstring
01e1 cd050      call     bdos      ;print the string
01e4 c9        ret
;
readcom:
;read the next command line to the conbuf
01e5 116b0      lxi      d,prompt
01e8 cdda0      call     print      ;command?
01eb 0e0a      mvi      c,rstring
01ed 117a0      lxi      d,conbuf
01f0 cd050      call     bdos      ;read command line
;          command line is present, scan it

```

```

01f3 21000      lxi      h,0      ;start with 0000
01f6 117c0      lxi      d,conlin;command line
01f9 la        readc: ldax     d      ;next command character
01fa 13         inx     d      ;to next command position
01fb b7         ora     a      ;cannot be end of command
01fc c8         rz

; not zero, numeric?
01fd d630      sui     '0'
01ff fe0a      cpi     10      ;carry if numeric
0201 d2130      jnc     endrd
; add-in next digit
0204 29        dad     h      ;*2
0205 4d        mov     c,l
0206 44        mov     b,h      ;bc = value * 2
0207 29        dad     h      ;*4
0208 29        dad     h      ;*8
0209 09        dad     b      ;*2 + *8 = *10
020a 85        add     l      ;+digit
020b 6f        mov     l,a
020c d2f90     jnc     readc   ;for another char
020f 24        inr     h      ;overflow
0210 c3f90     jmp     readc   ;for another char
; endrd:
; end of read, restore value in a
0213 c630      adi     '0'     ;command
0215 fe61      cpi     'a'     ;translate case?
0217 d8        rc
; lower case, mask lower case bits
0218 e65f      ani     101$1111b
021a c9        ret

;
;*****
;*
;* string data area for console messages
;*
;*****
badver:
021b 536f79     db      'sorry, you need cp/m version 2$'
; nospace:
023a 4e6f29     db      'no directory space$'
; datmsg:
024d 547970     db      'type data: $'
; errmsg:
0259 457272     db      'error, try again.$'
; prompt:
026b 4e6570     db      'next command? $'
;

```

```

;*****
;*
;* fixed and variable data area
;*
;*****
027a 21  conbuf: db      conlen  ;length of console buffer
027b      consiz: ds      1      ;resulting size after read
027c      conlin: ds     32     ;length 32 buffer
0021 =   conlen equ     $-consiz

;
029c      ds      32      ;16 level stack
stack:
02bc      end

```

Again, major improvements could be made to this particular program to enhance its operation. In fact, with some work, this program could evolve into a simple data base management system. One could, for example, assume a standard record size of 128 bytes, consisting of arbitrary fields within the record. A program, called GETKEY, could be developed which first reads a sequential file and extracts a specific field defined by the operator. For example, the command

```
GETKEY NAMES.DAT  LASTNAME 10 20
```

would cause GETKEY to read the data base file NAMES.DAT and extract the "LASTNAME" field from each record, starting at position 10 and ending at character 20. GETKEY builds a table in memory consisting of each particular LASTNAME field, along with its 16-bit record number location within the file. The GETKEY program then sorts this list, and writes a new file, called LASTNAME.KEY, which is an alphabetical list of LASTNAME fields with their corresponding record numbers. (This list is called an "inverted index" in information retrieval parlance.)

Rename the program shown above as QUERY, and massage it a bit so that it reads a sorted key file into memory. The command line might appear as:

```
QUERY NAMES.DAT LASTNAME.KEY
```

Instead of reading a number, the QUERY program reads an alphanumeric string which is a particular key to find in the NAMES.DAT data base. Since the LASTNAME.KEY list is sorted, you can find a particular entry quite rapidly by performing a "binary search," similar to looking up a name in the telephone book. That is, starting at both ends of the list, you examine the entry halfway in between and, if not matched, split either the upper half or the lower half for the next search. You'll quickly reach the item you're looking for (in log<sub>2</sub>(n) steps) where you'll find the corresponding record number. Fetch and display this record at the console, just as we have done in the program shown above.

At this point you're just getting started. With a little more work, you can allow a fixed grouping size which differs from the 128 byte record shown above. This is accomplished by keeping track of the record number as well as the byte offset within the record. Knowing the group size, you randomly access the record containing the proper group, offset to the beginning of the group within the record read sequentially until the group size has been exhausted.

Finally, you can improve QUERY considerably by allowing boolean expressions which compute the set of records which satisfy several relationships, such as a LASTNAME between HARDY and LAUREL, and an AGE less than 45. Display all the records which fit this description. Finally, if your lists are getting too big to fit into memory, randomly access your key files from the disk as well. One note of consolation after all this work: if you make it through the project, you'll have no more need for this manual!

## 6. SYSTEM FUNCTION SUMMARY.

FUNC	FUNCTION NAME	INPUT PARAMETERS	OUTPUT RESULTS
0	System Reset	none	none
1	Console Input	none	A = char
2	Console Output	E = char	none
3	Reader Input	none	A = char
4	Punch Output	E = char	none
5	List Output	E = char	none
6	Direct Console I/O	see def	see def
7	Get I/O Byte	none	A = IOBYTE
8	Set I/O Byte	E = IOBYTE	none
9	Print String	DE = .Buffer	none
10	Read Console Buffer	DE = .Buffer	see def
11	Get Console Status	none	A = 00/FF
12	Return Version Number	none	HL= Version*
13	Reset Disk System	none	see def
14	Select Disk	E = Disk Number	see def
15	Open File	DE = .FCB	A = Dir Code
16	Close File	DE = .FCB	A = Dir Code
17	Search for First	DE = .FCB	A = Dir Code
18	Search for Next	none	A = Dir Code
19	Delete File	DE = .FCB	A = Dir Code
20	Read Sequential	DE = .FCB	A = Err Code
21	Write Sequential	DE = .FCB	A = Err Code
22	Make File	DE = .FCB	A = Dir Code
23	Rename File	DE = .FCB	A = Dir Code
24	Return Login Vector	none	HL= Login Vect*
25	Return Current Disk	none	A = Cur Disk#
26	Set DMA Address	DE = .DMA	none
27	Get Addr(Alloc)	none	HL= .Alloc
28	Write Protect Disk	none	see def
29	Get R/O Vector	none	HL= R/O Vect*
30	Set File Attributes	DE = .FCB	see def
31	Get Addr(disk parms)	none	HL= .DPB
32	Set/Get User Code	see def	see def
33	Read Random	DE = .FCB	A = Err Code
34	Write Random	DE = .FCB	A = Err Code
35	Compute File Size	DE = .FCB	r0, r1, r2
36	Set Random Record	DE = .FCB	r0, r1, r2

\* Note that A = L, and B = H upon return

**CP/M 2.2 ALTERATION GUIDE**

## COPYRIGHT

Copyright (c) 1980 by Exidy Systems, Inc. All rights reserved. No part of this publication may be reproduced, transmitted, transcribed, stored in a retrieval system, or translated into any language, in any form or by any means, electronic, mechanical, magnetic, optical, chemical, manual, or otherwise, without the prior written permission of Exidy Systems, Inc., 1234 Elko Drive, Sunnyvale, California 94086.

Since this manual is tutorial in nature, permission is granted to reproduce or abstract the example procedures and sample programs for the purposes of inclusion within the reader's programs.

## DISCLAIMER

Exidy Systems, Inc. makes no representations or warranties with respect to the contents hereof and specifically disclaims any implied warranties of merchantability or fitness for any particular purpose. Further, Exidy Systems, Inc. reserves the right to revise this publication and to make changes from time to time in the content hereof without obligation of Exidy Systems, Inc. to notify any person of such revision or changes.

## TRADEMARKS

CP/M is a registered trademark of Digital Research.



**CP/M 2.2 ALTERATION GUIDE**

## COPYRIGHT

Copyright (c) 1980 by Exidy Systems, Inc. All rights reserved. No part of this publication may be reproduced, transmitted, transcribed, stored in a retrieval system, or translated into any language, in any form or by any means, electronic, mechanical, magnetic, optical, chemical, manual, or otherwise, without the prior written permission of Exidy Systems, Inc., 1234 Elko Drive, Sunnyvale, California 94086.

Since this manual is tutorial in nature, permission is granted to reproduce or abstract the example procedures and sample programs for the purposes of inclusion within the reader's programs.

## DISCLAIMER

Exidy Systems, Inc. makes no representations or warranties with respect to the contents hereof and specifically disclaims any implied warranties of merchantability or fitness for any particular purpose. Further, Exidy Systems, Inc. reserves the right to revise this publication and to make changes from time to time in the content hereof without obligation of Exidy Systems, Inc. to notify any person of such revision or changes.

## TRADEMARKS

CP/M is a registered trademark of Digital Research.

**Table Of Contents**  
**CP/M Alteration Guide**

1.	Introduction.....	177
2.	First Level System Regenerative.....	178
3.	Second Level System Generation.....	182
4.	Sample Getsys And Putsys Programs.....	186
5.	Diskette Organization.....	188
6.	The BIOS Entry Points.....	190
7.	A Sample BIOS.....	197
8.	A Sample Cold Start Loader.....	198
9.	Reserved Locations In Page Zero.....	199
10.	Disk Parameter Tables.....	201
11.	The DISKDEF Macro Library.....	206
12.	Sector Blocking And Deblocking.....	210
	Appendix A.....	212
	Appendix B.....	215
	Appendix C.....	226
	Appendix D.....	232
	Appendix E.....	235
	Appendix F.....	237
	Appendix G.....	242



## 1. INTRODUCTION

The standard CP/M system assumes operation on an Intel MDS-800 microcomputer development system, but is designed so that the user can alter a specific set of subroutines which define the hardware operating environment. In this way, the user can produce a diskette which operates with any IBM-3741 format compatible drive controller and other peripheral devices.

Although standard CP/M 2.0 is configured for single density floppy disks, field-alteration features allow adaptation to a wide variety of disk subsystems from single drive minidisks through high-capacity "hard disk" systems. In order to simplify the following adaptation process, we assume that CP/M 2.0 will first be configured for single density floppy disks where minimal editing and debugging tools are available. If an earlier version of CP/M is available, the customizing process is eased considerably. In this latter case, you may wish to briefly review the system generation process, and skip to later sections which discuss system alteration for non-standard disk systems.

In order to achieve device independence, CP/M is separated into three distinct modules:

- BIOS - basic I/O system which is environment dependent
- BDOS - basic disk operating system which is not dependent upon the hardware configuration
- CCP - the console command processor which uses the BDOS

Of these modules, only the BIOS is dependent upon the particular hardware. That is, the user can "patch" the distribution version of CP/M to provide a new BIOS which provides a customized interface between the remaining CP/M modules and the user's own hardware system. The purpose of this document is to provide a step-by-step procedure for patching your new BIOS into CP/M.

If CP/M is being tailored to your computer system for the first time, the new BIOS requires some relatively simple software development and testing. The standard BIOS is listed in Appendix B, and can be used as a model for the customized package. A skeletal version of the BIOS is given in Appendix C which can serve as the basis for a modified BIOS. In addition to the BIOS, the user must write a simple memory loader, called GETSYS, which brings the operating system into memory. In order to patch the new BIOS into CP/M, the user must write the reverse of GETSYS, called PUTSYS, which places an altered version of CP/M back onto the diskette. PUTSYS can be derived from GETSYS by changing the disk read commands into disk write commands. Sample skeletal GETSYS and PUTSYS programs are described in Section 3, and listed in Appendix D. In order to make the CP/M system work automatically, the user must also supply a cold start loader, similar to the one provided with CP/M (listed in Appendices A and B). A skeletal form of a cold start loader is given in Appendix E which can serve as a model for your loader.

(All Information Contained Herein is Proprietary to Digital Research.)

## 2. FIRST LEVEL SYSTEM REGENERATION

The procedure to follow to patch the CP/M system is given below in several steps. Address references in each step are shown with a following "H" which denotes the hexadecimal radix, and are given for a 20K CP/M system. For larger CP/M systems, add a "bias" to each address which is shown with a "+b" following it, where b is equal to the memory size - 20K. Values for b in various standard memory sizes are

24K:	b = 24K - 20K = 4K = 1000H
32K:	b = 32K - 20K = 12K = 3000H
40K:	b = 40K - 20K = 20K = 5000H
48K:	b = 48K - 20K = 28K = 7000H
56K:	b = 56K - 20K = 36K = 9000H
62K:	b = 62K - 20K = 42K = A800H
64K:	b = 64K - 20K = 44K = B000H

Note: The standard distribution version of CP/M is set for operation within a 20K memory system. Therefore, you must first bring up the 20K CP/M system, and then configure it for your actual memory size (see Second Level System Generation).

(1) Review Section 4 and write a GETSYS program which reads the first two tracks of a diskette into memory. The data from the diskette must begin at location 3380H. Code GETSYS so that it starts at location 100H (base of the TPA), as shown in the first part of Appendix d.

(2) Test the GETSYS program by reading a blank diskette into memory, and check to see that the data has been read properly, and that the diskette has not been altered in any way by the GETSYS program.

(3) Run the GETSYS program using an initialized CP/M diskette to see if GETSYS loads CP/M starting at 3380H (the operating system actually starts 128 bytes later at 3400H).

(4) Review Section 4 and write the PUTSYS program which writes memory starting at 3380H back onto the first two tracks of the diskette. The PUTSYS program should be located at 200H, as shown in the second part of Appendix D.

(5) Test the PUTSYS program using a blank uninitialized diskette by writing a portion of memory to the first two tracks; clear memory and read it back using GETSYS. Test PUTSYS completely, since this program will be used to alter CP/M on disk.

(6) Study Sections 5, 6, and 7, along with the distribution version of the BIOS given in Appendix B, and write a simple version which performs a similar function for the customized environment. Use the program given in Appendix C as a model. Call this new BIOS by the name CBIOS (customized BIOS). Implement only the primitive disk operations on a single drive, and simple console input/output functions in this phase.

(All Information Contained Herein is Proprietary to Digital Research.)

(7) Test CBIOS completely to ensure that it properly performs console character I/O and disk reads and writes. Be especially careful to ensure that no disk write operations occur accidentally during read operations, and check that the proper track and sectors are addressed on all reads and writes. Failure to make these checks may cause destruction of the initialized CP/M system after it is patched.

(8) Referring to Figure 1 in Section 5, note that the BIOS is placed between locations 4A00H and 4FFFH. Read the CP/M system using GETSYS and replace the BIOS segment by the new CBIOS developed in step (6) and tested in step (7). This replacement is done in the memory of the machine, and will be placed on the diskette in the next step.

(9) Use PUTSYS to place the patched memory image of CP/M onto the first two tracks of a blank diskette for testing.

(10) Use GETSYS to bring the copied memory image from the test diskette back into memory at 3380H, and check to ensure that it has loaded back properly (clear memory, if possible, before the load). Upon successful load, branch to the cold start code at location 4A00H. The cold start routine will initialize page zero, then jump to the CCP at location 3400H which will call the BDOS, which will call the CBIOS. The CBIOS will be asked by the CCP to read sixteen sectors on track 2, and if successful, CP/M will type "A>", the system prompt.

When you make it this far, you are almost on the air. If you have trouble, use whatever debug facilities you have available to trace and breakpoint your CBIOS.

(11) Upon completion of step (10), CP/M has promoted the console for a command input. Test the disk write operation by typing

```
SAVE 1 X.COM
```

(recall that all commands must be followed by a carriage return).

CP/M should respond with another prompt (after several disk accesses):

```
A>
```

If it does not, debug your disk write functions and retry.

(12) Then test the directory command by typing

```
DIR
```

CP/M should respond with

```
A: X      COM
```

(13) Test the erase command by typing

```
ERA X.COM
```

(All Information Contained Herein is Proprietary to Digital Research.)

CP/M should respond with the A prompt. When you make it this far, you should have an operational system which will only require a bootstrap loader to function completely.

(14) Write a bootstrap loader which is similar to GETSYS, and place it on track 0, sector 1 using PUTSYS (again using the test diskette, not the distribution diskette). See Sections 5 and 8 for more information on the bootstrap operation.

(15) Retest the new test diskette with the bootstrap loader installed by executing steps (11), (12), and (13). Upon completion of these tests, type a control-C (control and C keys simultaneously). The system should then execute a "warm start" which reboots the system, and types the A prompt.

(16) At this point, you probably have a good version of your customized CP/M system on your test diskette. Use GETSYS to load CP/M from your test diskette. Remove the test diskette, place the distribution diskette (or a legal copy) into the drive, and use PUTSYS to replace the distribution version by your customized version. Do not make this replacement if you are unsure of your patch since this step destroys the system which was sent to you from Digital Research.

(17) Load your modified CP/M system and test it by typing

DIR

CP/M should respond with a list of files which are provided on the initialized diskette. One such file should be the memory image for the debugger, called DDT.COM.

NOTE: from now on, it is important that you always reboot the CP/M system (ctl-C is sufficient) when the diskette is removed and replaced by another diskette, unless the new diskette is to be read only.

(18) Load and test the debugger by typing

DDT

(see the document "CP/M Dynamic Debugging Tool (DDT)" for operating procedures. You should take the time to become familiar with DDT, it will be your best friend in later steps.

(19) Before making further CBIOS modifications, practice using the editor (see the ED user's guide), and assembler (see the ASM user's guide). Then recode and test the GETSYS, PUTSYS, and CBIOS programs using ED, ASM, and DDT. Code and test a COPY program which does a sector-to-sector copy from one diskette to another to obtain back-up copies of the original diskette (NOTE: read your CP/M Licensing Agreement; it specifies your legal responsibilities when copying the CP/M system). Place the copyright notice

Copyright (c), 1979  
Digital Research

(All Information Contained Herein is Proprietary to Digital Research.)



on each copy which is made with your COPY program.

(20) Modify your CBIOS to include the extra functions for punches, readers, signon messages, and so-forth, and add the facilities for a additional disk drives, if desired. You can make these changes with the GETSYS and PUTSYS programs which you have developed, or you can refer to the following section, which outlines CP/M facilities which will aid you in the regeneration process.

You now have a good copy of the customized CP/M system. Note that although the CBIOS portion of CP/M which you have developed belongs to you, the modified version of CP/M which you have created can be copied for your use only (again, read your Licensing Agreement), and cannot be legally copied for anyone else's use.

It should be noted that your system remains file-compatible with all other CP/M systems, (assuming media compatibility, of course) which allows transfer of non-proprietary software between users of CP/M.

### 3. SECOND LEVEL SYSTEM GENERATION

Now that you have the CP/M system running, you will want to configure CP/M for your memory size. In general, you will first get a memory image of CP/M with the "MOVCPM" program (system relocater) and place this memory image into a named disk file. The disk file can then be loaded, examined, patched, and replaced using the debugger, and system generation program. For further details on the operation of these programs, see the "Guide to CP/M Features and Facilities" manual.

Your CBIOS and BOOT can be modified using ED, and assembled using ASM, producing files called CBIOS.HEX and BOOT.HEX, which contain the machine code for CBIOS and BOOT in Intel hex format.

To get the memory image of CP/M into the TPA configured for the desired memory size, give the command:

```
MOVCPM xx *
```

where "xx" is the memory size in decimal K bytes (e.g., 32 for 32K). The response will be:

```
CONSTRUCTING xxK CP/M VERS 2.0  
READY FOR "SYSGEN" OR  
"SAVE 34 CPMxx.COM"
```

At this point, an image of a CP/M in the TPA configured for the requested memory size. The memory image is at location 0900H through 227FH. (i.e., The BOOT is at 0900H, the CCP is at 980H, the BDOS starts at 1180H, and the BIOS is at 1F80H.) Note that the memory image has the standard MDS-800 BIOS and BOOT on it. It is now necessary to save the memory image in a file so that you can patch your CBIOS and CBOOT into it:

```
SAVE 34 CPMxx.COM
```

The memory image created by the "MOVCPM" program is offset by a negative bias so that it loads into the free area of the TPA, and thus does not interfere with the operation of CP/M in higher memory. This memory image can be subsequently loaded under DDT and examined or changed in preparation for a new generation of the system. DDT is loaded with the memory image by typing:

```
DDT CPMxx.COM
```

Load DDT, then read the CPM image

DDT should respond with

```
NEXT PC  
2300 0100  
-
```

(The DDT prompt)

You can then use the display and disassembly commands to examine

(All Information Contained Herein is Proprietary to Digital Research.)

portions of the memory image between 900H and 227FH. Note, however, that to find any particular address within the memory image, you must apply the negative bias to the CP/M address to find the actual address. Track 00, sector 01 is loaded to location 900H (you should find the cold start loader at 900H to 97FH), track 00, sector 02 is loaded into 980H (this is the base of the CCP), and so-forth through the entire CP/M system load. In a 20K system, for example, the CCP resides at the CP/M address 3400H, but is placed into memory at 980H by the SYSGEN program. Thus, the negative bias, denoted by n, satisfies

$$3400H + n = 980H, \text{ or } n = 980H - 3400H$$

Assuming two's complement arithmetic,  $n = D580H$ , which can be checked by

$$3400H + D580H = 10980H = 0980H \text{ (ignoring high-order overflow).}$$

Note that for larger systems, n satisfies

$$\begin{aligned} (3400H+b) + n &= 980H, \text{ or} \\ n &= 980H - (3400H + b), \text{ or} \\ n &= D580H - b. \end{aligned}$$

The value of n for common CP/M systems is given below

memory size	bias b	negative offset n
20K	0000H	D580H - 0000H = D580H
24K	1000H	D580H - 1000H = C580H
32K	3000H	D580H - 3000H = A580H
40K	5000H	D580H - 5000H = 8580H
48K	7000H	D580H - 7000H = 6580H
56K	9000H	D580H - 9000H = 4580H
62K	A800H	D580H - A800H = 2D80H
64K	B000H	D580H - B000H = 2580H

Assume, for example, that you want to locate the address x within the memory image loaded under DDT in a 20K system. First type

Hx,n                      Hexadecimal sum and difference

and DDT will respond with the value of x+n (sum) and x-n (difference). The first number printed by DDT will be the actual memory address in the image where the data or code will be found. The input

H3400,D580

for example, will produce 980H as the sum, which is where the CCP is located in the memory image under DDT.

Use the L command to disassemble portions the BIOS located at  $(4A00H+b)-n$  which, when you use the H command, produces an actual address of 1F80H. The disassembly command would thus be

(All Information Contained Herein is Proprietary to Digital Research.)

## L1F80

It is now necessary to patch in your CBOOT and CBIOS routines. The BOOT resides at location 0900H in the memory image. If the actual load address is "n", then to calculate the bias (m) use the command:

```
H900,n          Subtract load address from
                  target address.
```

The second number typed in response to the command is the desired bias (m). For example, if your BOOT executes at 0080H, the command:

```
H900,80
```

will reply

```
0980 0880          Sum and difference in hex.
```

Therefore, the bias "m" would be 0880H. To read-in the BOOT, give the command:

```
ICBOOT.HEX       Input file CBOOT.HEX
```

Then:

```
Rm              Read CBOOT with a bias of
                  m (=900H-n)
```

You may now examine your CBOOT with:

```
L900
```

We are now ready to replace the CBIOS. Examine the area at 1F80H where the original version of the CBIOS resides. Then type

```
ICBIOS.HEX       Ready the "hex" file for loading
```

assume that your CBIOS is being integrated into a 20K CP/M system, and thus is originated at location 4A00H. In order to properly locate the CBIOS in the memory image under DDT, we must apply the negative bias n for a 20K system when loading the hex file. This is accomplished by typing

```
RD580           Read the file with bias D580H
```

Upon completion of the read, re-examine the area where the CBIOS has been loaded (use an "L1F80" command), to ensure that it was loaded properly. When you are satisfied that the change has been made, return from DDT using a control-C or "G0" command.

Now use SYSGEN to replace the patched memory image back onto a diskette (use a test diskette until you are sure of your patch), as shown in the following interaction

(All Information Contained Herein is Proprietary to Digital Research.)

SYSGEN Start the SYSGEN program  
SYSGEN VERSION 2.0 Sign-on message from SYSGEN  
SOURCE DRIVE NAME (OR RETURN TO SKIP) Respond with a carriage return  
to skip the CP/M read operation  
since the system is already in  
memory.  
DESTINATION DRIVE NAME (OR RETURN TO REBOOT) Respond with "B" to write the  
new system to the diskette in  
drive B.  
DESTINATION ON B, THEN TYPE RETURN Place a scratch diskette in  
drive B, then type return.  
FUNCTION COMPLETE  
DESTINATION DRIVE NAME (OR RETURN TO REBOOT)

Place the scratch diskette in your drive A, and then perform a coldstart to bring up the new CP/M system you have configured.

Test the new CP/M system, and place the Digital Research copyright notice on the diskette, as specified in your Licensing Agreement:

Copyright (c), 1979  
Digital Research

#### 4. SAMPLE GETSYS AND PUTSYS PROGRAMS

The following program provides a framework for the GETSYS and PUTSYS programs referenced in Section 2. The READSEC and WRITESEC subroutines must be inserted by the user to read and write the specific sectors.

```

;   GETSYS PROGRAM - READ TRACKS 0 AND 1 TO MEMORY AT 3380H
;   REGISTER          USE
;   A                 (SCRATCH REGISTER)
;   B                 TRACK COUNT (0, 1)
;   C                 SECTOR COUNT (1,2,...,26)
;   DE                (SCRATCH REGISTER PAIR)
;   HL                LOAD ADDRESS
;   SP                SET TO STACK ADDRESS
;
START: LXI    SP,3380H    ;SET STACK POINTER TO SCRATCH AREA
       LXI    H, 3380H   ;SET BASE LOAD ADDRESS
       MVI    B, 0       ;START WITH TRACK 0
RDTRK:                ;READ NEXT TRACK (INITIALLY 0)
       MVI    C,1        ;READ STARTING WITH SECTOR 1
RDSEC:                ;READ NEXT SECTOR
       CALL   READSEC    ;USER-SUPPLIED SUBROUTINE
       LXI    D,128      ;MOVE LOAD ADDRESS TO NEXT 1/2 PAGE
       DAD    D           ;HL = HL + 128
       INR    C           ;SECTOR = SECTOR + 1
       MOV    A,C         ;CHECK FOR END OF TRACK
       CPI    27
       JC     RDSEC       ;CARRY GENERATED IF SECTOR < 27
;
;   ARRIVE HERE AT END OF TRACK, MOVE TO NEXT TRACK
       INR    B
       MOV    A,B         ;TEST FOR LAST TRACK
       CPI    2
       JC     RDTRK       ;CARRY GENERATED IF TRACK < 2
;
;   ARRIVE HERE AT END OF LOAD, HALT FOR NOW
       HLT
;
;   USER-SUPPLIED SUBROUTINE TO READ THE DISK
READSEC:
;   ENTER WITH TRACK NUMBER IN REGISTER B,
;   SECTOR NUMBER IN REGISTER C, AND
;   ADDRESS TO FILL IN HL
;
       PUSH   B           ;SAVE B AND C REGISTERS
       PUSH   H           ;SAVE HL REGISTERS
       .....
       perform disk read at this point, branch to
       label START if an error occurs
       .....
       POP    H           ;RECOVER HL
       POP    B           ;RECOVER B AND C REGISTERS
       RET                ;BACK TO MAIN PROGRAM

       END    START

```

Note that this program is assembled and listed in Appendix C for reference purposes, with an assumed origin of 100H. The hexadecimal operation codes which are listed on the left may be useful if the program has to be entered through your machine's front panel switches.

The PUTSYS program can be constructed from GETSYS by changing only a few operations in the GETSYS program given above, as shown in Appendix D. The register pair HL become the dump address (next address to write), and operations upon these registers do not change within the program. The READSEC subroutine is replaced by a WRITESEC subroutine which performs the opposite function: data from address HL is written to the track given by register B and sector given by register C. It is often useful to combine GETSYS and PUTSYS into a single program during the test and development phase, as shown in the Appendix.

## 5. DISKETTE ORGANIZATION

The sector allocation for the standard distribution version of CP/M is given here for reference purposes. The first sector (see table on the following page) contains an optional software boot section. Disk controllers are often set up to bring track 0, sector 1 into memory at a specific location (often location 0000H). The program in this sector, called BOOT, has the responsibility of bringing the remaining sectors into memory starting at location 3400H+b. If your controller does not have a built-in sector load, you can ignore the program in track 0, sector 1, and begin the load from track 0 sector 2 to location 3400H+b.

As an example, the Intel MDS-800 hardware cold start loader brings track 0, sector 1 into absolute address 3000H. Upon loading this sector, control transfers to location 3000H, where the bootstrap operation commences by loading the remainder of tracks 0, and all of track 1 into memory, starting at 3400H+b. The user should note that this bootstrap loader is of little use in a non-MDS environment, although it is useful to examine it since some of the boot actions will have to be duplicated in your cold start loader.



Track	Sector	Page	Memory Address	C/P/M Module Name
00	01		(boot address)	Cold Start Loader
00	02	00	3400H+b	CCP
"	03	"	3480H+b	"
"	04	01	3500H+b	"
"	05	"	3580H+b	"
"	06	02	3600H+b	"
"	07	"	3680H+b	"
"	08	03	3700H+b	"
"	09	"	3780H+b	"
"	10	04	3800H+b	"
"	11	"	3880H+b	"
"	12	05	3900H+b	"
"	13	"	3980H+b	"
"	14	06	3A00H+b	"
"	15	"	3A80H+b	"
"	16	07	3B00H+b	"
00	17	"	3B80H+b	CCP
00	18	08	3C00H+b	BDOS
"	19	"	3C80H+b	"
"	20	09	3D00H+b	"
"	21	"	3D80H+b	"
"	22	10	3E00H+b	"
"	23	"	3E80H+b	"
"	24	11	3F00H+b	"
"	25	"	3F80H+b	"
"	26	12	4000H+b	"
01	01	"	4080H+b	"
"	02	13	4100H+b	"
"	03	"	4180H+b	"
"	04	14	4200H+b	"
"	05	"	4280H+b	"
"	06	15	4300H+b	"
"	07	"	4380H+b	"
"	08	16	4400H+b	"
"	09	"	4480H+b	"
"	10	17	4500H+b	"
"	11	"	4580H+b	"
"	12	18	4600H+b	"
"	13	"	4680H+b	"
"	14	19	4700H+b	"
"	15	"	4780H+b	"
"	16	20	4800H+b	"
"	17	"	4880H+b	"
"	18	21	4900H+b	"
01	19	"	4980H+b	BDOS
01	20	22	4A00H+b	BIOS
"	21	"	4A80H+b	"
"	23	23	4B00H+b	"
"	24	"	4B80H+b	"
"	25	24	4C00H+b	"
01	26	"	4C80H+b	BIOS
02-76	01-26			(directory and data)

## 6. THE BIOS ENTRY POINTS

The entry points into the BIOS from the cold start loader and BDOS are detailed below. Entry to the BIOS is through a "jump vector" located at 4A00H+b, as shown below (see Appendices B and C, as well). The jump vector is a sequence of 17 jump instructions which send program control to the individual BIOS subroutines. The BIOS subroutines may be empty for certain functions (i.e., they may contain a single RET operation) during regeneration of CP/M, but the entries must be present in the jump vector.

The jump vector at 4A00H+b takes the form shown below, where the individual jump addresses are given to the left:

4A00H+b	JMP BOOT	; ARRIVE HERE FROM COLD START LOAD
4A03H+b	JMP WBOOT	; ARRIVE HERE FOR WARM START
4A06H+b	JMP CONST	; CHECK FOR CONSOLE CHAR READY
4A09H+b	JMP CONIN	; READ CONSOLE CHARACTER IN
4A0CH+b	JMP CONOUT	; WRITE CONSOLE CHARACTER OUT
4A0FH+b	JMP LIST	; WRITE LISTING CHARACTER OUT
4A12H+b	JMP PUNCH	; WRITE CHARACTER TO PUNCH DEVICE
4A15H+b	JMP READER	; READ READER DEVICE
4A18H+b	JMP HOME	; MOVE TO TRACK 00 ON SELECTED DISK
4A1BH+b	JMP SELDSK	; SELECT DISK DRIVE
4A1EH+b	JMP SETTRK	; SET TRACK NUMBER
4A21H+b	JMP SETSEC	; SET SECTOR NUMBER
4A24H+b	JMP SETDMA	; SET DMA ADDRESS
4A27H+b	JMP READ	; READ SELECTED SECTOR
4A2AH+b	JMP WRITE	; WRITE SELECTED SECTOR
4A2DH+b	JMP LISTST	; RETURN LIST STATUS
4A30H+b	JMP SECTAN	; SECTOR TRANSLATE SUBROUTINE

Each jump address corresponds to a particular subroutine which performs the specific function, as outlined below. There are three major divisions in the jump table: the system (re)initialization which results from calls on BOOT and WBOOT, simple character I/O performed by calls on CONST, CONIN, CONOUT, LIST, PUNCH, READER, and LISTST, and diskette I/O performed by calls on HOME, SELDSK, SETTRK, SETSEC, SETDMA, READ, WRITE, and SECTAN.

All simple character I/O operations are assumed to be performed in ASCII, upper and lower case, with high order (parity bit) set to zero. An end-of-file condition for an input device is given by an ASCII control-z (1AH). Peripheral devices are seen by CP/M as "logical" devices, and are assigned to physical devices within the BIOS.

In order to operate, the BDOS needs only the CONST, CONIN, and CONOUT subroutines (LIST, PUNCH, and READER may be used by PIP, but not the BDOS). Further, the LISTST entry is used currently only by DESPOOL, and thus, the initial version of CBIOS may have empty subroutines for the remaining ASCII devices.

The characteristics of each device are

- CONSOLE     The principal interactive console which communicates with the operator, accessed through CONST, CONIN, and CONOUT. Typically, the CONSOLE is a device such as a CRT or Teletype.
- LIST        The principal listing device, if it exists on your system, which is usually a hard-copy device, such as a printer or Teletype.
- PUNCH       The principal tape punching device, if it exists, which is normally a high-speed paper tape punch or Teletype.
- READER      The principal tape reading device, such as a simple optical reader or Teletype.

Note that a single peripheral can be assigned as the LIST, PUNCH, and READER device simultaneously. If no peripheral device is assigned as the LIST, PUNCH, or READER device, the CBIOS created by the user may give an appropriate error message so that the system does not "hang" if the device is accessed by PIP or some other user program. Alternately, the PUNCH and LIST routines can just simply return, and the READER routine can return with a LAH (ctl-Z) in reg A to indicate immediate end-of-file.

For added flexibility, the user can optionally implement the "IOBYTE" function which allows reassignment of physical and logical devices. The IOBYTE function creates a mapping of logical to physical devices which can be altered during CP/M processing (see the STAT command). The definition of the IOBYTE function corresponds to the Intel standard as follows: a single location in memory (currently location 0003H) is maintained, called IOBYTE, which defines the logical to physical device mapping which is in effect at a particular time. The mapping is performed by splitting the IOBYTE into four distinct fields of two bits each, called the CONSOLE, READER, PUNCH, and LIST fields, as shown below:

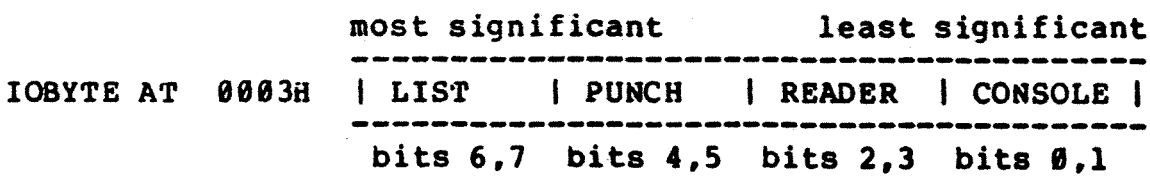

The value in each field can be in the range 0-3, defining the assigned source or destination of each logical device. The values which can be assigned to each field are given below

CONSOLE field (bits 0,1)

- 0 - console is assigned to the console printer device (TTY:)
- 1 - console is assigned to the CRT device (CRT:)
- 2 - batch mode: use the READER as the CONSOLE input, and the LIST device as the CONSOLE output (BAT:)
- 3 - user defined console device (UC1:)

READER field (bits 2,3)

- 0 - READER is the Teletype device (TTY:)
- 1 - READER is the high-speed reader device (RDR:)
- 2 - user defined reader # 1 (UR1:)
- 3 - user defined reader # 2 (UR2:)

PUNCH field (bits 4,5)

- 0 - PUNCH is the Teletype device (TTY:)
- 1 - PUNCH is the high speed punch device (PUN:)
- 2 - user defined punch # 1 (UP1:)
- 3 - user defined punch # 2 (UP2:)

LIST field (bits 6,7)

- 0 - LIST is the Teletype device (TTY:)
- 1 - LIST is the CRT device (CRT:)
- 2 - LIST is the line printer device (LPT:)
- 3 - user defined list device (UL1:)

Note again that the implementation of the IOBYTE is optional, and affects only the organization of your CBIOS. No CP/M systems use the IOBYTE (although they tolerate the existence of the IOBYTE at location 0003H), except for PIP which allows access to the physical devices, and STAT which allows logical-physical assignments to be made and/or displayed (for more information, see the "CP/M Features and Facilities Guide"). In any case, the IOBYTE implementation should be omitted until your basic CBIOS is fully implemented and tested; then add the IOBYTE to increase your facilities.

Disk I/O is always performed through a sequence of calls on the various disk access subroutines which set up the disk number to access, the track and sector on a particular disk, and the direct memory access (DMA) address involved in the I/O operation. After all these parameters have been set up, a call is made to the READ or WRITE function to perform the actual I/O operation. Note that there is often a single call to SELDSK to select a disk drive, followed by a number of read or write operations to the selected disk before selecting another drive for subsequent operations. Similarly, there may be a single call to set the DMA address, followed by several calls which read or write from the selected DMA address before the DMA address is changed. The track and sector subroutines are always called before the READ or WRITE operations are performed.

Note that the READ and WRITE routines should perform several retries (10 is standard) before reporting the error condition to the BDOS. If the error condition is returned to the BDOS, it will report the error to the user. The HOME subroutine may or may not actually perform the track 00 seek, depending upon your controller characteristics; the important point is that track 00 has been selected for the next operation, and is often treated in exactly the same manner as SETTRK with a parameter of 00.

The exact responsibilities of each entry point subroutine are given below:

**BOOT** The BOOT entry point gets control from the cold start loader and is responsible for basic system initialization, including sending a signon message (which can be omitted in the first version). If the IOBYTE function is implemented, it must be set at this point. The various system parameters which are set by the WBOOT entry point must be initialized, and control is transferred to the CCP at 3400H+b for further processing. Note that reg C must be set to zero to select drive A.

**WBOOT** The WBOOT entry point gets control when a warm start occurs. A warm start is performed whenever a user program branches to location 0000H, or when the CPU is reset from the front panel. The CP/M system must be loaded from the first two tracks of drive A up to, but not including, the BIOS (or CBIOS, if you have completed your patch). System parameters must be initialized as shown below:

location 0,1,2 set to JMP WBOOT for warm starts  
(0000H: JMP 4A03H+b)  
location 3 set initial value of IOBYTE, if  
implemented in your CBIOS  
location 5,6,7 set to JMP BDOS, which is the  
primary entry point to CP/M for  
transient programs. (0005H: JMP  
3C06H+b)

(see Section 9 for complete details of page zero use)  
Upon completion of the initialization, the WBOOT program must branch to the CCP at 3400H+b to (re)start the system. Upon entry to the CCP, register C is set to the drive to select after system initialization.

**CONST** Sample the status of the currently assigned console device and return 0FFH in register A if a character is ready to read, and 00H in register A if no console characters are ready.

**CONIN** Read the next console character into register A, and

(All Information Contained Herein is Proprietary to Digital Research.)

set the parity bit (high order bit) to zero. If no console character is ready, wait until a character is typed before returning.

- CONOUT Send the character from register C to the console output device. The character is in ASCII, with high order parity bit set to zero. You may want to include a time-out on a line feed or carriage return, if your console device requires some time interval at the end of the line (such as a TI Silent 700 terminal). You can, if you wish, filter out control characters which cause your console device to react in a strange way (a control-z causes the Lear Seigler terminal to clear the screen, for example).
- LIST Send the character from register C to the currently assigned listing device. The character is in ASCII with zero parity.
- PUNCH Send the character from register C to the currently assigned punch device. The character is in ASCII with zero parity.
- READER Read the next character from the currently assigned reader device into register A with zero parity (high order bit must be zero), an end of file condition is reported by returning an ASCII control-z (1AH).
- HOME Return the disk head of the currently selected disk (initially disk A) to the track 00 position. If your controller allows access to the track 0 flag from the drive, step the head until the track 0 flag is detected. If your controller does not support this feature, you can translate the HOME call into a call on SETTRK with a parameter of 0.
- SELDSK Select the disk drive given by register C for further operations, where register C contains 0 for drive A, 1 for drive B, and so-forth up to 15 for drive P (the standard CP/M distribution version supports four drives). On each disk select, SELDSK must return in HL the base address of a 16-byte area, called the Disk Parameter Header, described in the Section 10. For standard floppy disk drives, the contents of the header and associated tables does not change, and thus the program segment included in the sample CBIOS performs this operation automatically. If there is an attempt to select a non-existent drive, SELDSK returns HL=0000H as an error indicator. Although SELDSK must return the header address on each call, it is advisable to postpone the actual physical disk select operation until an I/O function (seek, read or write) is actually performed, since disk selects often occur without ultimately performing any disk I/O, and many controllers will unload the head of the current disk

(All Information Contained Herein is Proprietary to Digital Research.)

before selecting the new drive. This would cause an excessive amount of noise and disk wear.

#### SETTRK

Register BC contains the track number for subsequent disk accesses on the currently selected drive. You can choose to seek the selected track at this time, or delay the seek until the next read or write actually occurs. Register BC can take on values in the range 0-76 corresponding to valid track numbers for standard floppy disk drives, and 0-65535 for non-standard disk subsystems.

#### SETSEC

Register BC contains the sector number (1 through 26) for subsequent disk accesses on the currently selected drive. You can choose to send this information to the controller at this point, or instead delay sector selection until a read or write operation occurs.

#### SETDMA

Register BC contains the DMA (disk memory access) address for subsequent read or write operations. For example, if B = 00H and C = 80H when SETDMA is called, then all subsequent read operations read their data into 80H through 0FFH, and all subsequent write operations get their data from 80H through 0FFH, until the next call to SETDMA occurs. The initial DMA address is assumed to be 80H. Note that the controller need not actually support direct memory access. If, for example, all data is received and sent through I/O ports, the CBIOS which you construct will use the 128 byte area starting at the selected DMA address for the memory buffer during the following read or write operations.

#### READ

Assuming the drive has been selected, the track has been set, the sector has been set, and the DMA address has been specified, the READ subroutine attempts to read one sector based upon these parameters, and returns the following error codes in register A:

0	no errors occurred
1	non-recoverable error condition occurred

Currently, CP/M responds only to a zero or non-zero value as the return code. That is, if the value in register A is 0 then CP/M assumes that the disk operation completed properly. If an error occurs, however, the CBIOS should attempt at least 10 retries to see if the error is recoverable. When an error is reported the BDOS will print the message "BDOS ERR ON x: BAD SECTOR". The operator then has the option of typing <cr> to ignore the error, or ctl-C to abort.

#### WRITE

Write the data from the currently selected DMA address to the currently selected drive, track, and sector. The data should be marked as "non deleted data" to

maintain compatibility with other CP/M systems. The error codes given in the READ command are returned in register A, with error recovery attempts as described above.

**LISTST** Return the ready status of the list device. Used by the DESPOOL program to improve console response during its operation. The value 00 is returned in A if the list device is not ready to accept a character, and 0FFH if a character can be sent to the printer. Note that a 00 value always suffices.

**SECTRAN** Performs sector logical to physical sector translation in order to improve the overall response of CP/M. Standard CP/M systems are shipped with a "skew factor" of 6, where six physical sectors are skipped between each logical read operation. This skew factor allows enough time between sectors for most programs to load their buffers without missing the next sector. In particular computer systems which use fast processors, memory, and disk subsystems, the skew factor may be changed to improve overall response. Note, however, that you should maintain a single density IBM compatible version of CP/M for information transfer into and out of your computer system, using a skew factor of 6. In general, SECTRAN receives a logical sector number in BC, and a translate table address in DE. The sector number is used as an index into the translate table, with the resulting physical sector number in HL. For standard systems, the tables and indexing code is provided in the CBIOS and need not be changed.



## 7. A SAMPLE BIOS

The program shown in Appendix C can serve as a basis for your first BIOS. The simplest functions are assumed in this BIOS, so that you can enter it through the front panel, if absolutely necessary. Note that the user must alter and insert code into the subroutines for CONST, CONIN, CONOUT, READ, WRITE, and WAITIO subroutines. Storage is reserved for user-supplied code in these regions. The scratch area reserved in page zero (see Section 9) for the BIOS is used in this program, so that it could be implemented in ROM, if desired.

Once operational, this skeletal version can be enhanced to print the initial sign-on message and perform better error recovery. The subroutines for LIST, PUNCH, and READER can be filled-out, and the IOBYTE function can be implemented.

## 8. A SAMPLE COLD START LOADER

The program shown in Appendix D can serve as a basis for your cold start loader. The disk read function must be supplied by the user, and the program must be loaded somehow starting at location 0000. Note that space is reserved for your patch so that the total amount of storage required for the cold start loader is 128 bytes. Eventually, you will probably want to get this loader onto the first disk sector (track 0, sector 1), and cause your controller to load it into memory automatically upon system start-up. Alternatively, you may wish to place the cold start loader into ROM, and place it above the CP/M system. In this case, it will be necessary to originate the program at a higher address, and key-in a jump instruction at system start-up which branches to the loader. Subsequent warm starts will not require this key-in operation, since the entry point 'WBOOT' gets control, thus bringing the system in from disk automatically. Note also that the skeletal cold start loader has minimal error recovery, which may be enhanced on later versions.

## 9. RESERVED LOCATIONS IN PAGE ZERO

Main memory page zero, between locations 000H and 0FFH, contains several segments of code and data which are used during CP/M processing. The code and data areas are given below for reference purposes.

Locations from to	Contents
0000H - 0002H	Contains a jump instruction to the warm start entry point at location 4A03H+b. This allows a simple programmed restart (JMP 0000H) or manual restart from the front panel.
0003H - 0003H	Contains the Intel standard IOBYTE, which is optionally included in the user's CBIOS, as described in Section 6.
0004H - 0004H	Current default drive number (0=A, ..., 15=P).
0005H - 0007H	Contains a jump instruction to the BDOS, and serves two purposes: JMP 0005H provides the primary entry point to the BDOS, as described in the manual "CP/M Interface Guide," and LHL 0006H brings the address field of the instruction to the HL register pair. This value is the lowest address in memory used by CP/M (assuming the CCP is being overlaid). Note that the DDT program will change the address field to reflect the reduced memory size in debug mode.
0008H - 0027H	(interrupt locations 1 through 5 not used)
0030H - 0037H	(interrupt location 6, not currently used - reserved)
0038H - 003AH	Restart 7 - Contains a jump instruction into the DDT or SID program when running in debug mode for programmed breakpoints, but is not otherwise used by CP/M.
003BH - 003FH	(not currently used - reserved)
0040H - 004FH	16 byte area reserved for scratch by CBIOS, but is not used for any purpose in the distribution version of CP/M
0050H - 005BH	(not currently used - reserved)
005CH - 007CH	default file control block produced for a transient program by the Console Command Processor.
007DH - 007FH	Optional default random record position

0080H - 00FFH      default 128 byte disk buffer (also filled with the command line when a transient is loaded under the CCP).

Note that this information is set-up for normal operation under the CP/M system, but can be overwritten by a transient program if the BDOS facilities are not required by the transient.

If, for example, a particular program performs only simple I/O and must begin execution at location 0, it can be first loaded into the TPA, using normal CP/M facilities, with a small memory move program which gets control when loaded (the memory move program must get control from location 0100H, which is the assumed beginning of all transient programs). The move program can then proceed to move the entire memory image down to location 0, and pass control to the starting address of the memory load. Note that if the BIOS is overwritten, or if location 0 (containing the warm start entry point) is overwritten, then the programmer must bring the CP/M system back into memory with a cold start sequence.

## 10. DISK PARAMETER TABLES.

Tables are included in the BIOS which describe the particular characteristics of the disk subsystem used with CP/M. These tables can be either hand-coded, as shown in the sample CBIOS in Appendix C, or automatically generated using the DISKDEF macro library, as shown in Appendix B. The purpose here is to describe the elements of these tables.

In general, each disk drive has an associated (16-byte) disk parameter header which both contains information about the disk drive and provides a scratchpad area for certain BDOS operations. The format of the disk parameter header for each drive is shown below

Disk Parameter Header								
XLT	0000	0000	0000	DIRBUF	DPB	CSV	ALV	
16b	16b	16b	16b	16b	16b	16b	16b	16b

where each element is a word (16-bit) value. The meaning of each Disk Parameter Header (DPH) element is

- XLT** Address of the logical to physical translation vector, if used for this particular drive, or the value 0000H if no sector translation takes place (i.e, the physical and logical sector numbers are the same). Disk drives with identical sector skew factors share the same translate tables.
- 0000** Scratchpad values for use within the BDOS (initial value is unimportant).
- DIRBUF** Address of a 128 byte scratchpad area for directory operations within BDOS. All DPH's address the same scratchpad area.
- DPB** Address of a disk parameter block for this drive. Drives with identical disk characteristics address the same disk parameter block.
- CSV** Address of a scratchpad area used for software check for changed disks. This address is different for each DPH.
- ALV** Address of a scratchpad area used by the BDOS to keep disk storage allocation information. This address is different for each DPH.

Given n disk drives, the DPH's are arranged in a table whose first row of 16 bytes corresponds to drive 0, with the last row corresponding to drive n-1. The table thus appears as

(All Information Contained Herein is Proprietary to Digital Research.)

DPBASE:

```

-----
00 |XLT 00| 0000 | 0000 | 0000 |DIRBUF|DBP 00|CSV 00|ALV 00|
-----
01 |XLT 01| 0000 | 0000 | 0000 |DIRBUF|DBP 01|CSV 01|ALV 01|
-----
                                (and so-forth through)
-----
n-1|XLTn-1| 0000 | 0000 | 0000 |DIRBUF|DBPn-1|CSVn-1|ALVn-1|
-----

```

where the label DPBASE defines the base address of the DPH table.

A responsibility of the SELDSK subroutine is to return the base address of the DPH for the selected drive. The following sequence of operations returns the table address, with a 0000H returned if the selected drive does not exist.

```

NDISKS    EQU    4    ;NUMBER OF DISK DRIVES
.....
SELDISK:
                ;SELECT DISK GIVEN BY BC
LXI        H,0000H   ;ERROR CODE
MOV        A,C       ;DRIVE OK?
CPI        NDISKS    ;CY IF SO
RNC        ;RET IF ERROR
;NO ERROR, CONTINUE
MOV        L,C       ;LOW(DISK)
MOV        H,B       ;HIGH(DISK)
DAD        H         ;*2
DAD        H         ;*4
DAD        H         ;*8
DAD        H         ;*16
LXI        D,DPBASE  ;FIRST DPH
DAD        D         ;DPH(DISK)
RET

```

The translation vectors (XLT 00 through XLTn-1) are located elsewhere in the BIOS, and simply correspond one-for-one with the logical sector numbers zero through the sector count-1. The Disk Parameter Block (DPB) for each drive is more complex. A particular DPB, which is addressed by one or more DPH's, takes the general form

```

-----
| SPT |BSH|BLM|EXM| DSM | DRM |AL0|AL1| CKS | OFF |
-----
16b  8b  8b  8b  16b  16b  8b  8b  16b  16b
-----

```

where each is a byte or word value, as shown by the "8b" or "16b" indicator below the field.

SPT is the total number of sectors per track

BSH is the data allocation block shift factor, determined by the data block allocation size.

(All Information Contained Herein is Proprietary to Digital Research.)

EXM is the extent mask, determined by the data block allocation size and the number of disk blocks.

DSM determines the total storage capacity of the disk drive

DRM determines the total number of directory entries which can be stored on this drive AL0,AL1 determine reserved directory blocks.

CKS is the size of the directory check vector

OFF is the number of reserved tracks at the beginning of the (logical) disk.

The values of BSH and BLM determine (implicitly) the data allocation size BLS, which is not an entry in the disk parameter block. Given that the designer has selected a value for BLS, the values of BSH and BLM are shown in the table below

BLS	BSH	BLM
1,024	3	7
2,048	4	15
4,096	5	31
8,192	6	63
16,384	7	127

where all values are in decimal. The value of EXM depends upon both the BLS and whether the DSM value is less than 256 or greater than 255, as shown in the following table

BLS	DSM < 256	DSM > 255
1,024	0	N/A
2,048	1	0
4,096	3	1
8,192	7	3
16,384	15	7

The value of DSM is the maximum data block number supported by this particular drive, measured in BLS units. The product BLS times (DSM+1) is the total number of bytes held by the drive and, of course, must be within the capacity of the physical disk, not counting the reserved operating system tracks.

The DRM entry is the one less than the total number of directory entries, which can take on a 16-bit value. The values of AL0 and AL1, however, are determined by DRM. The two values AL0 and AL1 can together be considered a string of 16-bits, as shown below.

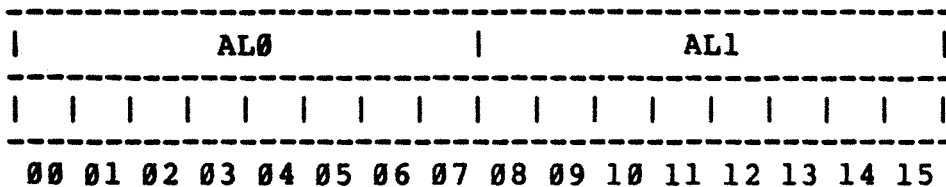

where position 00 corresponds to the high order bit of the byte labelled AL0, and 15 corresponds to the low order bit of the byte labelled AL1. Each bit position reserves a data block for number of directory entries, thus allowing a total of 16 data blocks to be assigned for directory entries (bits are assigned starting at 00 and filled to the right until position 15). Each directory entry occupies 32 bytes, resulting in the following table

BLS	Directory Entries
1,024	32 times # bits
2,048	64 times # bits
4,096	128 times # bits
8,192	256 times # bits
16,384	512 times # bits

Thus, if DRM = 127 (128 directory entries), and BLS = 1024, then there are 32 directory entries per block, requiring 4 reserved blocks. In this case, the 4 high order bits of AL0 are set, resulting in the values AL0 = 0F0H and AL1 = 00H.

The CKS value is determined as follows: if the disk drive media is removable, then  $CKS = (DRM+1)/4$ , where DRM is the last directory entry number. If the media is fixed, then set CKS = 0 (no directory records are checked in this case).

Finally, the OFF field determines the number of tracks which are skipped at the beginning of the physical disk. This value is automatically added whenever SETTRK is called, and can be used as a mechanism for skipping reserved operating system tracks, or for partitioning a large disk into smaller segmented sections.

To complete the discussion of the DPB, recall that several DPH's can address the same DPB if their drive characteristics are identical. Further, the DPB can be dynamically changed when a new drive is addressed by simply changing the pointer in the DPH since the BDOS copies the DPB values to a local area whenever the SELDSK function is invoked.

Returning back to the DPH for a particular drive, note that the two address values CSV and ALV remain. Both addresses reference an area of uninitialized memory following the BIOS. The areas must be unique for each drive, and the size of each area is determined by the values in the DPB.

The size of the area addressed by CSV is CKS bytes, which is sufficient to hold the directory check information for this particular drive. If  $CKS = (DRM+1)/4$ , then you must reserve  $(DRM+1)/4$  bytes for directory check use. If CKS = 0, then no storage is reserved.

(All Information Contained Herein is Proprietary to Digital Research.)



The size of the area addressed by ALV is determined by the maximum number of data blocks allowed for this particular disk, and is computed as  $(DSM/8)+1$ .

The CBIOS shown in Appendix C demonstrates an instance of these tables for standard 8" single density drives. It may be useful to examine this program, and compare the tabular values with the definitions given above.

## 11. THE DISKDEF MACRO LIBRARY.

A macro library is shown in Appendix F, called DISKDEF, which greatly simplifies the table construction process. You must have access to the MAC macro assembler, of course, to use the DISKDEF facility, while the macro library is included with all CP/M 2.0 distribution disks.

A BIOS disk definition consists of the following sequence of macro statements:

```
MACLIB   DISKDEF
.....
DISKS    n
DISKDEF  0,...
DISKDEF  1,...
.....
DISKDEF  n-1
.....
ENDEF
```

where the MACLIB statement loads the DISKDEF.LIB file (on the same disk as your BIOS) into MAC's internal tables. The DISKS macro call follows, which specifies the number of drives to be configured with your system, where n is an integer in the range 1 to 16. A series of DISKDEF macro calls then follow which define the characteristics of each logical disk, 0 through n-1 (corresponding to logical drives A through P). Note that the DISKS and DISKDEF macros generate the in-line fixed data tables described in the previous section, and thus must be placed in a non-executable portion of your BIOS, typically directly following the BIOS jump vector.

The remaining portion of your BIOS is defined following the DISKDEF macros, with the ENDEF macro call immediately preceding the END statement. The ENDEF (End of Diskdef) macro generates the necessary uninitialized RAM areas which are located in memory above your BIOS.

The form of the DISKDEF macro call is

```
DISKDEF  dn,fsc,lsc,[skf],bls,dks,dir,cks,ofs,[0]
```

where

```
dn      is the logical disk number, 0 to n-1
fsc     is the first physical sector number (0 or 1)
lsc     is the last sector number
skf     is the optional sector skew factor
bls     is the data allocation block size
dir     is the number of directory entries
cks     is the number of "checked" directory entries
ofs     is the track offset to logical track 00
[0]     is an optional 1.4 compatibility flag
```

The value "dn" is the drive number being defined with this DISKDEF

(All Information Contained Herein is Proprietary to Digital Research.)

macro invocation. The "fsc" parameter accounts for differing sector numbering systems, and is usually 0 or 1. The "lsc" is the last numbered sector on a track. When present, the "skf" parameter defines the sector skew factor which is used to create a sector translation table according to the skew. If the number of sectors is less than 256, a single-byte table is created, otherwise each translation table element occupies two bytes. No translation table is created if the skf parameter is omitted (or equal to 0). The "bls" parameter specifies the number of bytes allocated to each data block, and takes on the values 1024, 2048, 4096, 8192, or 16384. Generally, performance increases with larger data block sizes since there are fewer directory references and logically connected data records are physically close on the disk. Further, each directory entry addresses more data and the BIOS-resident ram space is reduced. The "dks" specifies the total disk size in "bls" units. That is, if the bls = 2048 and dks = 1000, then the total disk capacity is 2,048,000 bytes. If dks is greater than 255, then the block size parameter bls must be greater than 1024. The value of "dir" is the total number of directory entries which may exceed 255, if desired. The "cks" parameter determines the number of directory items to check on each directory scan, and is used internally to detect changed disks during system operation, where an intervening cold or warm start has not occurred (when this situation is detected, CP/M automatically marks the disk read/only so that data is not subsequently destroyed). As stated in the previous section, the value of cks = dir when the media is easily changed, as is the case with a floppy disk subsystem. If the disk is permanently mounted, then the value of cks is typically 0, since the probability of changing disks without a restart is quite low. The "ofs" value determines the number of tracks to skip when this particular drive is addressed, which can be used to reserve additional operating system space or to simulate several logical drives on a single large capacity physical drive. Finally, the [0] parameter is included when file compatibility is required with versions of 1.4 which have been modified for higher density disks. This parameter ensures that only 16K is allocated for each directory record, as was the case for previous versions. Normally, this parameter is not included.

For convenience and economy of table space, the special form

DISKDEF i,j

gives disk i the same characteristics as a previously defined drive j. A standard four-drive single density system, which is compatible with version 1.4, is defined using the following macro invocations:

```

DISKS      4
DISKDEF   0,1,26,6,1024,243,64,64,2
DISKDEF   1,0
DISKDEF   2,0
DISKDEF   3,0
.....
ENDEF

```

with all disks having the same parameter values of 26 sectors per track (numbered 1 through 26), with 6 sectors skipped between each access, 1024 bytes per data block, 243 data blocks for a total of 243k byte disk capacity, 64 checked directory entries, and two operating system tracks.

The DISKS macro generates n Disk Parameter Headers (DPH's), starting at the DPH table address DPBASE generated by the macro. Each disk header block contains sixteen bytes, as described above, and correspond one-for-one to each of the defined drives. In the four drive standard system, for example, the DISKS macro generates a table of the form:

```

DPBASE EQU $
DPE0:  DW  XLT0,0000H,0000H,0000H,DIRBUF,DPB0,CSV0,ALV0
DPE1:  DW  XLT0,0000H,0000H,0000H,DIRBUF,DPB0,CSV1,ALV1
DPE2:  DW  XLT0,0000H,0000H,0000H,DIRBUF,DPB0,CSV2,ALV2
DPE3:  DW  XLT0,0000H,0000H,0000H,DIRBUF,DPB0,CSV3,ALV3

```

where the DPH labels are included for reference purposes to show the beginning table addresses for each drive 0 through 3. The values contained within the disk parameter header are described in detail in the previous section. The check and allocation vector addresses are generated by the ENDEF macro in the ram area following the BIOS code and tables.

Note that if the "skf" (skew factor) parameter is omitted (or equal to 0), the translation table is omitted, and a 0000H value is inserted in the XLT position of the disk parameter header for the disk. In a subsequent call to perform the logical to physical translation, SECTRAN receives a translation table address of DE = 0000H, and simply returns the original logical sector from BC in the HL register pair. A translate table is constructed when the skf parameter is present, and the (non-zero) table address is placed into the corresponding DPH's. The table shown below, for example, is constructed when the standard skew factor skf = 6 is specified in the DISKDEF macro call:

```

XLT0:  DB  1,7,13,19,25,5,11,17,23,3,9,15,21
        DB  2,8,14,20,26,6,12,18,24,4,10,16,22

```

Following the ENDEF macro call, a number of uninitialized data areas are defined. These data areas need not be a part of the BIOS which is loaded upon cold start, but must be available between the BIOS and the end of memory. The size of the uninitialized RAM area is determined by EQU statements generated by the ENDEF macro. For a standard four-drive system, the ENDEF macro might produce

(All Information Contained Herein is Proprietary to Digital Research.)

```
4C72 =      BEGDAT EQU $
          (data areas)
4DB0 =      ENDDAT EQU $
013C =      DATSIZ EQU $-BEGDAT
```

which indicates that uninitialized RAM begins at location 4C72H, ends at 4DB0H-1, and occupies 013CH bytes. You must ensure that these addresses are free for use after the system is loaded.

After modification, you can use the STAT program to check your drive characteristics, since STAT uses the disk parameter block to decode the drive information. The STAT command form

STAT d:DSK:

decodes the disk parameter block for drive d (d=A,...,P) and displays the values shown below:

```
r: 128 Byte Record Capacity
k: Kilobyte Drive Capacity
d: 32 Byte Directory Entries
c: Checked Directory Entries
e: Records/ Extent
b: Records/ Block
s: Sectors/ Track
t: Reserved Tracks
```

Three examples of DISKDEF macro invocations are shown below with corresponding STAT parameter values (the last produces a full 8-megabyte system).

```
DISKDEF 0,1,58,,2048,256,128,128,2
r=4096, k=512, d=128, c=128, e=256, b=16, s=58, t=2
```

```
DISKDEF 0,1,58,,2048,1024,300,0,2
r=16384, k=2048, d=300, c=0, e=128, b=16, s=58, t=2
```

```
DISKDEF 0,1,58,,16384,512,128,128,2
r=65536, k=8192, d=128, c=128, e=1024, b=128, s=58, t=2
```

(All Information Contained Herein is Proprietary to Digital Research.)

## 12. SECTOR BLOCKING AND DEBLOCKING.

Upon each call to the BIOS WRITE entry point, the CP/M BDOS includes information which allows effective sector blocking and deblocking where the host disk subsystem has a sector size which is a multiple of the basic 128-byte unit. The purpose here is to present a general-purpose algorithm which can be included within your BIOS which uses the BDOS information to perform the operations automatically.

Upon each call to WRITE, the BDOS provides the following information in register C:

0	=	normal sector write
1	=	write to directory sector
2	=	write to the first sector of a new data block

Condition 0 occurs whenever the next write operation is into a previously written area, such as a random mode record update, when the write is to other than the first sector of an unallocated block, or when the write is not into the directory area. Condition 1 occurs when a write into the directory area is performed. Condition 2 occurs when the first record (only) of a newly allocated data block is written. In most cases, application programs read or write multiple 128 byte sectors in sequence, and thus there is little overhead involved in either operation when blocking and deblocking records since pre-read operations can be avoided when writing records.

Appendix G lists the blocking and deblocking algorithms in skeletal form (this file is included on your CP/M disk). Generally, the algorithms map all CP/M sector read operations onto the host disk through an intermediate buffer which is the size of the host disk sector. Throughout the program, values and variables which relate to the CP/M sector involved in a seek operation are prefixed by "sek," while those related to the host disk system are prefixed by "hst." The equate statements beginning on line 29 of Appendix G define the mapping between CP/M and the host system, and must be changed if other than the sample host system is involved.

The entry points BOOT and WBOOT must contain the initialization code starting on line 57, while the SELDSK entry point must be augmented by the code starting on line 65. Note that although the SELDSK entry point computes and returns the Disk Parameter Header address, it does not physically selected the host disk at this point (it is selected later at READHST or WRITEHST). Further, SETTRK, SETTRK, and SETDMA simply store the values, but do not take any other action at this point. SECTRAN performs a trivial trivial function of returning the physical sector number.

The principal entry points are READ and WRITE, starting on lines 110 and 125, respectively. These subroutines take the place of your previous READ and WRITE operations.

The actual physical read or write takes place at either WRITEHST or READHST, where all values have been prepared: hstdsk is the host

(All Information Contained Herein is Proprietary to Digital Research.)

disk number, hsttrk is the host track number, and hstsec is the host sector number (which may require translation to a physical sector number). You must insert code at this point which performs the full host sector read or write into, or out of, the buffer at hstbuf of length hstsiz. All other mapping functions are performed by the algorithms.

This particular algorithm was tested using an 80 megabyte hard disk unit which was originally configured for 128 byte sectors, producing approximately 35 megabytes of formatted storage. When configured for 512 byte host sectors, usable storage increased to 57 megabytes, with a corresponding 400% improvement in overall response. In this situation, there is no apparent overhead involved in deblocking sectors, with the advantage that user programs still maintain the (less memory consuming) 128-byte sectors. This is primarily due, of course, to the information provided by the BDOS which eliminates the necessity for pre-read operations to take place.

## APPENDIX A: THE MDS COLD START LOADER

```

;      MDS-800 Cold Start Loader for CP/M 2.0
;
;      Version 2.0 August, 1979
;
0000 = false equ 0
ffff = true  equ not false
0000 = testing equ false
;
      if testing
bias equ 03400h
      endif
      if not testing
0000 = bias equ 0000h
      endif
0000 = cpmb equ bias ;base of dos load
0806 = bdos equ 806h+bias ;entry to dos for calls
1880 = bdose equ 1880h+bias ;end of dos load
1600 = boot equ 1600h+bias ;cold start entry point
1603 = rboot equ boot+3 ;warm start entry point
;
3000 org 3000h ;loaded here by hardware
;
1880 = bdosl equ bdose-cpmb
0002 = ntrks equ 2 ;tracks to read
0031 = bdoss equ bdosl/128 ;# sectors in bdos
0019 = bdos0 equ 25 ;# on track 0
0018 = bdosl equ bdoss-bdos0 ;# on track 1
;
f800 = mon80 equ 0f800h ;intel monitor base
ff0f = rmon80 equ 0ff0fh ;restart location for mon80
0078 = base equ 078h ;'base' used by controller
0079 = rtype equ base+1 ;result type
007b = rbyte equ base+3 ;result byte
007f = reset equ base+7 ;reset controller
;
0078 = dstat equ base ;disk status port
0079 = ilow equ base+1 ;low iopb address
007a = ihigh equ base+2 ;high iopb address
00ff = bsw equ 0ffh ;boot switch
0003 = recal equ 3h ;recalibrate selected drive
0004 = readf equ 4h ;disk read function
0100 = stack equ 100h ;use end of boot for stack
;
rstart:
3000 310001 lxi sp,stack;in case of call to mon80
; clear disk status
3003 db79 in rtype
3005 db7b in rbyte
; check if boot switch is off
coldstart:
3007 dbff in bsw
3009 e602 ani 02h ;switch on?
300b e20730 jnz coldstart

```



```

; clear the controller
300e d37f out reset ;logic cleared
;
;
3010 0602 mvi b,ntrks ;number of tracks to read
3012 214230 lxi h,iopb0
;
start:
;
; read first/next track into cpmb
3015 7d mov a,l
3016 d379 out ilow
3018 7c mov a,h
3019 d37a out ihigh
301b db78 wait0: in dstat
301d e604 ani 4
301f ca1b30 jz wait0
;
; check disk status
3022 db79 in rtype
3024 e603 ani 11b
3026 fe02 cpi 2
;
if testing
cnc rmon80 ;go to monitor if 11 or 10
endif
if not testing
3028 d20030 jnc rstart ;retry the load
endif
;
302b db7b in rbyte ;i/o complete, check status
; if not ready, then go to mon80
302d 17 ral
302e dc0fff cc rmon80 ;not ready bit set
3031 1f rar ;restore
3032 e61e ani 11110b ;overrun/addr err/seek/crc
;
if testing
cnc rmon80 ;go to monitor
endif
if not testing
3034 c20030 jnz rstart ;retry the load
endif
;
;
3037 110700 lxi d,iopb1 ;length of iopb
303a 19 dad d ;addressing next iopb
303b 05 dcr b ;count down tracks
303c c21530 jnz start
;
;
; jmp boot, print message, set-up jmps
303f c30016 jmp boot
;
; parameter blocks

```

```

3042 80      iopb0:  db      80h      ;iocw, no update
3043 04      db      readf     ;read function
3044 19      db      bdos0    ;# sectors to read trk 0
3045 00      db      0         ;track 0
3046 02      db      2         ;start with sector 2, trk 0
3047 0000    dw      cpmb     ;start at base of bdos
0007 =      iopbl  equ      $-iopb0
;
3049 80      iopbl:  db      80h
304a 04      db      readf
304b 18      db      bdosl    ;sectors to read on track 1
304c 01      db      1         ;track 1
304d 01      db      1         ;sector 1
304e 800c    dw      cpmb+bdos0*128 ;base of second rd
3050      end

```

## APPENDIX B: THE MDS BASIC I/O SYSTEM (BIOS)

```

;      mds-800 i/o drivers for cp/m 2.0
;      (four drive single density version)
;
;      version 2.0 august, 1979
;
0014 = vers      equ      20      ;version 2.0
;
;      copyright (c) 1979
;      digital research
;      box 579, pacific grove
;      california, 93950
;
4a00      org      4a00h      ;base of bios in 20k system
3400 =    cpmb      equ      3400h      ;base of cpm ccp
3c06 =    bdos      equ      3c06h      ;base of bdos in 20k system
1600 =    cpml      equ      $-cpmb      ;length (in bytes) of cpm system
002c =    nsects   equ      cpml/128;number of sectors to load
0002 =    offset   equ      2          ;number of disk tracks used by cp
0004 =    cdisk    equ      0004h      ;address of last logged disk
0080 =    buff     equ      0080h      ;default buffer address
000a =    retry    equ      10         ;max retries on disk i/o before e
;
;      perform following functions
;      boot      cold start
;      wboot     warm start (save i/o byte)
;      (boot and wboot are the same for mds)
;      const     console status
;               reg-a = 00 if no character ready
;               reg-a = ff if character ready
;      conin     console character in (result in reg-a)
;      conout    console character out (char in reg-c)
;      list      list out (char in reg-c)
;      punch     punch out (char in reg-c)
;      reader    paper tape reader in (result to reg-a)
;      home      move to track 00
;
;      (the following calls set-up the io parameter bloc
;      mds, which is used to perform subsequent reads an
;      seldsk   select disk given by reg-c (0,1,2...)
;      settrk   set track address (0,...76) for sub r/w
;      setsec   set sector address (1,...,26)
;      setdma   set subsequent dma address (initially 80h)
;
;      read/write assume previous calls to set i/o parms
;      read     read track/sector to preset dma address
;      write    write track/sector from preset dma address
;
;      jump vector for individual routines
4a00 c3b34a      jmp      boot
4a03 c3c34a wboote: jmp      wboot
4a06 c3614b      jmp      const
4a09 c3644b      jmp      conin
4a0c c36a4b      jmp      conout

```

```

4a0f c36d4b      jmp      list
4a12 c3724b      jmp      punch
4a15 c3754b      jmp      reader
4a18 c3784b      jmp      home
4a1b c37d4b      jmp      seldsk
4ale c3a74b      jmp      settrk
4a21 c3ac4b      jmp      setsec
4a24 c3bb4b      jmp      setdma
4a27 c3c14b      jmp      read
4a2a c3ca4b      jmp      write
4a2d c3704b      jmp      listst ;list status
4a30 c3b14b      jmp      sectran
;
maclib diskdef ;load the disk definition library
disks 4 ;four disks
4a33+= dpbase equ $ ;base of disk parameter blocks
4a33+824a00 dpe0: dw xlt0,0000h ;translate table
4a37+000000 dw 0000h,0000h ;scratch area
4a3b+6e4c73 dw dirbuf,dpb0 ;dir buff,param block
4a3f+0d4dee dw csv0,alv0 ;check, alloc vectors
4a43+824a00 dpe1: dw xlt1,0000h ;translate table
4a47+000000 dw 0000h,0000h ;scratch area
4a4b+6e4c73 dw dirbuf,dpb1 ;dir buff,param block
4a4f+3c4d1d dw csv1,alv1 ;check, alloc vectors
4a53+824a00 dpe2: dw xlt2,0000h ;translate table
4a57+000000 dw 0000h,0000h ;scratch area
4a5b+6e4c73 dw dirbuf,dpb2 ;dir buff,param block
4a5f+6b4d4c dw csv2,alv2 ;check, alloc vectors
4a63+824a00 dpe3: dw xlt3,0000h ;translate table
4a67+000000 dw 0000h,0000h ;scratch area
4a6b+6e4c73 dw dirbuf,dpb3 ;dir buff,param block
4a6f+9a4d7b dw csv3,alv3 ;check, alloc vectors
diskdef 0,1,26,6,1024,243,64,64,offset
4a73+= dpb0 equ $ ;disk parm block
4a73+1a00 dw 26 ;sec per track
4a75+03 db 3 ;block shift
4a76+07 db 7 ;block mask
4a77+00 db 0 ;extnt mask
4a78+f200 dw 242 ;disk size-1
4a7a+3f00 dw 63 ;directory max
4a7c+c0 db 192 ;alloc0
4a7d+00 db 0 ;allocl
4a7e+1000 dw 16 ;check size
4a80+0200 dw 2 ;offset
4a82+= xlt0 equ $ ;translate table
4a82+01 db 1
4a83+07 db 7
4a84+0d db 13
4a85+13 db 19
4a86+19 db 25
4a87+05 db 5
4a88+0b db 11
4a89+11 db 17
4a8a+17 db 23
4a8b+03 db 3

```

```

4a8c+09      db      9
4a8d+0f      db      15
4a8e+15      db      21
4a8f+02      db      2
4a90+08      db      8
4a91+0e      db      14
4a92+14      db      20
4a93+1a      db      26
4a94+06      db      6
4a95+0c      db      12
4a96+12      db      18
4a97+18      db      24
4a98+04      db      4
4a99+0a      db      10
4a9a+10      db      16
4a9b+16      db      22
              diskdef 1,0

4a73+=      dpb1      equ      dpb0      ;equivalent parameters
001f+=      als1      equ      als0      ;same allocation vector size
0010+=      css1      equ      css0      ;same checksum vector size
4a82+=      xlt1      equ      xlt0      ;same translate table
              diskdef 2,0

4a73+=      dpb2      equ      dpb0      ;equivalent parameters
001f+=      als2      equ      als0      ;same allocation vector size
0010+=      css2      equ      css0      ;same checksum vector size
4a82+=      xlt2      equ      xlt0      ;same translate table
              diskdef 3,0

4a73+=      dpb3      equ      dpb0      ;equivalent parameters
001f+=      als3      equ      als0      ;same allocation vector size
0010+=      css3      equ      css0      ;same checksum vector size
4a82+=      xlt3      equ      xlt0      ;same translate table
              ;
              ;
              ;      end of controller - independent code, the remaini
              ;      are tailored to the particular operating environm
              ;      be altered for any system which differs from the
              ;
              ;      the following code assumes the mds monitor exists
              ;      and uses the i/o subroutines within the monitor
              ;
              ;      we also assume the mds system has four disk drive
00fd =      revrt      equ      0fdh      ;interrupt revert port
00fc =      intc       equ      0fch      ;interrupt mask port
00f3 =      icon       equ      0f3h      ;interrupt control port
007e =      inte       equ      0111$1110b;enable rst 0(warm boot),rst 7
              ;
              ;      mds monitor equates
f800 =      mon80      equ      0f800h    ;mds monitor
ff0f =      rmon80     equ      0ff0fh    ;restart mon80 (boot error)
f803 =      ci         equ      0f803h    ;console character to reg-a
f806 =      ri         equ      0f806h    ;reader in to reg-a
f809 =      co         equ      0f809h    ;console char from c to console o
f80c =      po         equ      0f80ch    ;punch char from c to punch devic
f80f =      lo         equ      0f80fh    ;list from c to list device
f812 =      csts       equ      0f812h    ;console status 00/ff to register

```

```

;
; disk ports and commands
0078 = base equ 78h ;base of disk command io ports
0078 = dstat equ base ;disk status (input)
0079 = rtype equ base+1 ;result type (input)
007b = rbyte equ base+3 ;result byte (input)
;
0079 = ilow equ base+1 ;iopb low address (output)
007a = ihigh equ base+2 ;iopb high address (output)
;
0004 = readf equ 4h ;read function
0006 = writf equ 6h ;write function
0003 = recal equ 3h ;recalibrate drive
0004 = iordy equ 4h ;i/o finished mask
000d = cr equ 0dh ;carriage return
000a = lf equ 0ah ;line feed
;
; signon: ;signon message: xxk cp/m vers y.y
4a9c 0d0a0a db cr,lf,lf
4a9f 3230 db '20' ;sample memory size
4aa1 6b2043f db 'k cp/m vers '
4aad 322e30 db vers/10+'0','.',vers mod 10+'0'
4ab0 0d0a00 db cr,lf,0
;
boot: ;print signon message and go to ccp
; (note: mds boot initialized iobyte at 0003h)
4ab3 310001 lxi sp,buff+80h
4ab6 219c4a lxi h,signon
4ab9 cdd34b call prmsg ;print message
4abc af xra a ;clear accumulator
4abd 320400 sta cdisk ;set initially to disk a
4ac0 c30f4b jmp gocpm ;go to cp/m
;
;
wboot:; loader on track 0, sector 1, which will be skippe
; read cp/m from disk - assuming there is a 128 byt
; start.
;
4ac3 318000 lxi sp,buff ;using dma - thus 80 thru ff ok f
;
4ac6 0e0a mvi c,retry ;max retries
4ac8 c5 push b
wboot0:;enter here on error retries
4ac9 010034 lxi b,cpmb ;set dma address to start of disk
4acc cdbb4b call setdma
4acf 0e00 mvi c,0 ;boot from drive 0
4ad1 cd7d4b call seldsk
4ad4 0e00 mvi c,0
4ad6 cda74b call settrk ;start with track 0
4ad9 0e02 mvi c,2 ;start reading sector 2
4adb cdac4b call setsec
;
; read sectors, count nsects to zero
4ade cl pop b ;10-error count
4adf 062c mvi b,nsects

```

```

rdsec: ;read next sector
4ael c5      push      b          ;save sector count
4ae2 cdcl4b  call      read
4ae5 c2494b  jnz      booterr ;retry if errors occur
4ae8 2a6c4c  lhld     iod          ;increment dma address
4aeb 118000  lxi      d,128       ;sector size
4aee 19      dad      d          ;incremented dma address in hl
4aef 44      mov      b,h
4af0 4d      mov      c,l          ;ready for call to set dma
4af1 cdbb4b  call     setdma
4af4 3a6b4c  lda      ios          ;sector number just read
4af7 fela    cpi      26           ;read last sector?
4af9 da054b  jc      rd1
;
4afc 3a6a4c  lda      iot          ;get track to register a
4aff 3c      inr      a
4b00 4f      mov      c,a          ;ready for call
4b01 cda74b  call     settrk
4b04 af      xra      a            ;clear sector number
4b05 3c      inr      a            ;to next sector
4b06 4f      mov      c,a          ;ready for call
4b07 cdac4b  call     setsec
4b0a cl     pop      b          ;recall sector count
4b0b 05     dcr      b            ;done?
4b0c c2e14a  jnz     rdsec
;
;
; done with the load, reset default buffer address
; gocpm: ;(enter here from cold start boot)
; enable rst0 and rst7
4b0f f3     di
4b10 3e12   mvi     a,12h        ;initialize command
4b12 d3fd   out     revrt
4b14 af     xra     a
4b15 d3fc   out     intc         ;cleared
4b17 3e7e   mvi     a,inte       ;rst0 and rst7 bits on
4b19 d3fc   out     intc
4b1b af     xra     a
4b1c d3f3   out     icon         ;interrupt control
;
;
; set default buffer address to 80h
4ble 018000 lxi     b,buff
4b21 cdbb4b call     setdma
;
;
; reset monitor entry points
4b24 3ec3   mvi     a,jmp
4b26 320000 sta     0
4b29 21034a lxi     h,wboote
4b2c 220100 shld    1             ;jmp wboot at location 00
4b2f 320500 sta     5
4b32 21063c lxi     h,bdos
4b35 220600 shld    6             ;jmp bdos at location 5
4b38 323800 sta     7*8          ;jmp to mon80 (may have been chan
4b3b 2100f8 lxi     h,mon80
4b3e 223900 shld    7*8+1
;
; leave iobyte set

```

```

;          previously selected disk was b, send parameter to
4b41 3a0400  lda      cdisk  ;last logged disk number
4b44 4f      mov      c,a    ;send to ccp to log it in
4b45 fb      ei
4b46 c30034  jmp      cpmb

;
;          error condition occurred, print message and retry
booterr:
4b49 c1      pop      b          ;recall counts
4b4a 0d      dcr      c
4b4b ca524b  jz      booter0
;          try again
4b4e c5      push     b
4b4f c3c94a  jmp      wboot0

;
booter0:
;          otherwise too many retries
4b52 215b4b  lxi     h,bootmsg
4b55 cdd34b  call    prmsg
4b58 c30fff  jmp     rmon80 ;mds hardware monitor

;
bootmsg:
4b5b 3f626f4 db      '?boot',0

;
;
const: ;console status to reg-a
;      (exactly the same as mds call)
4b61 c312f8 jmp     csts

;
conin: ;console character to reg-a
4b64 cd03f8 call    ci
4b67 e67f  ani     7fh ;remove parity bit
4b69 c9      ret

;
conout: ;console character from c to console out
4b6a c309f8 jmp     co

;
list: ;list device out
;      (exactly the same as mds call)
4b6d c30ff8 jmp     lo

;
listst:
;      return list status
4b70 af      xra     a
4b71 c9      ret          ;always not ready

;
punch: ;punch device out
;      (exactly the same as mds call)
4b72 c30cf8 jmp     po

;
reader: ;reader character in to reg-a
;      (exactly the same as mds call)
4b75 c306f8 jmp     ri

;
home: ;move to home position

```



```

;      treat as track 00 seek
4b78 0e00      mvi      c,0
4b7a c3a74b    jmp      settrk
;
seldsk: ;select disk given by register c
4b7d 210000    lxi      h,0000h ;return 0000 if error
4b80 79        mov      a,c
4b81 fe04      cpi      ndisks ;too large?
4b83 d0        rnc      ;leave hl = 0000
;
4b84 e602      ani      l0b      ;00 00 for drive 0,1 and 10 10 fo
4b86 32664c    sta      dbank    ;to select drive bank
4b89 79        mov      a,c      ;00, 01, 10, 11
4b8a e601      ani      lb       ;mds has 0,1 at 78, 2,3 at 88
4b8c b7        ora      a        ;result 00?
4b8d ca924b    jz      setdrive
4b90 3e30      mvi      a,00110000b ;selects drive 1 in bank
setdrive:
4b92 47        mov      b,a      ;save the function
4b93 21684c    lxi      h,i0f    ;io function
4b96 7e        mov      a,m
4b97 e6cf      ani      11001111b ;mask out disk number
4b99 b0        ora      b        ;mask in new disk number
4b9a 77        mov      m,a      ;save it in iopb
4b9b 69        moy     l,0
4b9c 2600      mvi     h,0       ;hl=disk number
4b9e 29        dad     h        ;*2
4b9f 29        dad     h        ;*4
4ba0 29        dad     h        ;*8
4ba1 29        dad     h        ;*16
4ba2 11334a    lxi     d,dpbase
4ba5 19        dad     d        ;hl=disk header table address
4ba6 c9        ret
;
;
settrk: ;set track address given by c
4ba7 216a4c    lxi     h,iot
4baa 71        mov     m,c
4bab c9        ret
;
setsec: ;set sector number given by c
4bac 216b4c    lxi     h,ios
4baf 71        mov     m,c
4bb0 c9        ret
sectran:
;translate sector bc using table at de
4bb1 0600      mvi     b,0       ;double precision sector number i
4bb3 eb        xchg    ;translate table address to hl
4bb4 09        dad     b        ;translate(sector) address
4bb5 7e        mov     a,m      ;translated sector number to a
4bb6 326b4c    sta     ios
4bb9 6f        moy     l,a      ;return sector number in l
4bba c9        ret
;
setdma: ;set dma address given by regs b,c

```

```

4bbb 69      mov     l,c
4bbc 60      mov     h,b
4bbd 226c4c  shld   iod
4bc0 c9      ret

;
read:        ;read next disk record (assuming disk/trk/sec/dma
4bc1 0e04    mvi     c,readf ;set to read function
4bc3 cde04b  call   setfunc
4bc6 cdf04b  call   waitio  ;perform read function
4bc9 c9      ret                ;may have error set in reg-a

;
;
write:       ;disk write function
4bca 0e06    mvi     c,writf
4bcc cde04b  call   setfunc ;set to write function
4bcf cdf04b  call   waitio
4bd2 c9      ret                ;may have error set

;
;
; utility subroutines
prmsg:       ;print message at h,l to 0
4bd3 7e      mov     a,m
4bd4 b7      ora     a        ;zero?
4bd5 c8      rz

; more to print
4bd6 e5      push   h
4bd7 4f      mov     c,a
4bd8 cd6a4b  call   conout
4bdb e1      pop    h
4bdc 23      inx   h
4bdd c3d34b  jmp    prmsg

;
setfunc:     ; set function for next i/o (command in reg-c)
4be0 21684c  lxi    h,iof    ;io function address
4be3 7e      mov     a,m      ;get it to accumulator for maskin
4be4 e6f8    ani    11111000b ;remove previous command
4be6 b1      ora     c        ;set to new command
4be7 77      mov     m,a      ;replaced in iopb

; the mds-800 controller req's disk bank bit in sec
; mask the bit from the current i/o function
4be8 e620    ani    00100000b ;mask the disk select bit
4bea 216b4c  lxi    h,ios     ;address the sector selec
4bed b6      ora     m        ;select proper disk bank
4bee 77      mov     m,a      ;set disk select bit on/o
4bef c9      ret

;
waitio:      mvi     c,retry ;max retries before perm error
rewait:      ;
4bf2 cd3f4c  call   intype   ;in rtype
4bf5 cd4c4c  call   inbyte   ;clears the controller

;
4bf8 3a664c  lda    dbank    ;set bank flags

```

```

4bfb b7          ora      a          ;zero if drive 0,1 and nz
4bfc 3e67        mvi      a,iopb and 0ffh ;low address for iopb
4bfe 064c        mvi      b,iopb shr 8    ;high address for iopb
4c00 c20b4c     jnz      iodrl         ;drive bank 1?
4c03 d379        out      ilow          ;low address to controlle
4c05 78          mov      a,b
4c06 d37a        out      ihigh         ;high address
4c08 c3104c     jmp      wait0         ;to wait for complete
;
iodrl:          ;drive bank 1
4c0b d389        out      ilow+10h       ;88 for drive bank 10
4c0d 78          mov      a,b
4c0e d38a        out      ihigh+10h
;
4c10 cd594c     wait0:   call     instat        ;wait for completion
4c13 e604        ani      iordy         ;ready?
4c15 cal04c     jz       wait0
;
;          check io completion ok
4c18 cd3f4c     call     intype        ;must be io complete (00)
;          00 unlinked i/o complete, 01 linked i/o comple
;          10 disk status changed 11 (not used)
4c1b fe02        cpi      l0b          ;ready status change?
4c1d ca324c     jz       wready
;
;          must be 00 in the accumulator
4c20 b7          ora      a
4c21 c2384c     jnz      werror        ;some other condition, re
;
;          check i/o error bits
4c24 cd4c4c     call     inbyte
4c27 17          ral
4c28 da324c     jc       wready        ;unit not ready
4c2b 1f          rar
4c2c e6fe        ani      11111110b    ;any other errors?
4c2e c2384c     jnz      werror
;
;          read or write is ok, accumulator contains zero
4c31 c9          ret
;
wready:        ;not ready, treat as error for now
4c32 cd4c4c     call     inbyte        ;clear result byte
4c35 c3384c     jmp      trycount
;
werror:        ;return hardware malfunction (crc, track, seek, e
;          the mds controller has returned a bit in each pos
;          of the accumulator, corresponding to the conditio
;          0 - deleted data (accepted as ok above)
;          1 - crc error
;          2 - seek error
;          3 - address error (hardware malfunction)
;          4 - data over/under flow (hardware malfunct
;          5 - write protect (treated as not ready)
;          6 - write error (hardware malfunction)
;          7 - not ready

```

```

;      (accumulator bits are numbered 7 6 5 4 3 2 1 0)
;
;      it may be useful to filter out the various condit
;      but we will get a permanent error message if it i
;      recoverable.  in any case, the not ready conditio
;      treated as a separate condition for later improve
trycount:
;      register c contains retry count, decrement 'til z
4c38 0d      dcr      c
4c39 c2f24b  jnz      await ;for another try
;
;      cannot recover from error
4c3c 3e01    mvi      a,1      ;error code
4c3e c9      ret
;
;      intype, inbyte, instat read drive bank 00 or 10
4c3f 3a664c intype:  lda      dbank
4c42 b7      ora      a
4c43 c2494c jnz      intypl ;skip to bank 10
4c46 db79    in       rtype
4c48 c9      ret
4c49 db89    intypl: in      rtype+10h      ;78 for 0,1 88 for 2,3
4c4b c9      ret
;
4c4c 3a664c inbyte:  lda      dbank
4c4f b7      ora      a
4c50 c2564c jnz      inbytl
4c53 db7b    in       rbyte
4c55 c9      ret
4c56 db8b    inbytl: in      rbyte+10h
4c58 c9      ret
;
4c59 3a664c instat:  lda      dbank
4c5c b7      ora      a
4c5d c2634c jnz      instal
4c60 db78    in       dstat
4c62 c9      ret
4c63 db88    instal:  in      dstat+10h
4c65 c9      ret
;
;
;      data areas (must be in ram)
4c66 00      dbank:  db      0          ;disk bank 00 if drive 0,1
;                          ;          10 if drive 2,3
;
;      iopb: ;io parameter block
4c67 80      db      80h      ;normal i/o operation
4c68 04      ioof:   db      readf   ;io function, initial read
4c69 01      ion:    db      1        ;number of sectors to read
4c6a 02      iot:    db      offset  ;track number
4c6b 01      ios:    db      1        ;sector number
4c6c 8000    iod:    dw      buff     ;io address
;
;
;      define ram areas for bdos operation

```

```

                                endef
4c6e+=      begdat  equ      $
4c6e+      dirbuf: ds      128      ;directory access buffer
4ceet+     alv0:   ds      31
4d0d+     csv0:   ds      16
4d1d+     alv1:   ds      31
4d3c+     csv1:   ds      16
4d4c+     alv2:   ds      31
4d6b+     csv2:   ds      16
4d7b+     alv3:   ds      31
4d9a+     csv3:   ds      16
4daa+=     enddat  equ      $
013c+=     datsiz  equ      $-begdat
4daa      end

```

## APPENDIX C: A SKELETAL CBIOS

```

; skeletal cbios for first level of cp/m 2.0 altera
;
0014 = msize equ 20 ;cp/m version memory size in kilo
;
; "bias" is address offset from 3400h for memory sy
; than 16k (referred to as "b" throughout the text)
;
0000 = bias equ (msize-20)*1024
3400 = ccp equ 3400h+bias ;base of ccp
3c06 = bdos equ ccp+806h ;base of bdos
4a00 = bios equ ccp+1600h ;base of bios
0004 = cdisk equ 0004h ;current disk number 0=a,...,15=p
0003 = iobyte equ 0003h ;intel i/o byte
;
4a00 org bios ;origin of this program
002c = nsects equ ($-ccp)/128 ;warm start sector count
;
; jump vector for individual subroutines
4a00 c39c4a jmp boot ;cold start
4a03 c3a64a wboote: jmp wboot ;warm start
4a06 c3114b jmp const ;console status
4a09 c3244b jmp conin ;console character in
4a0c c3374b jmp conout ;console character out
4a0f c3494b jmp list ;list character out
4a12 c34d4b jmp punch ;punch character out
4a15 c34f4b jmp reader ;reader character out
4a18 c3544b jmp home ;move head to home positi
4a1b c35a4b jmp seldisk ;select disk
4a1e c37d4b jmp settrk ;set track number
4a21 c3924b jmp setsec ;set sector number
4a24 c3ad4b jmp setdma ;set dma address
4a27 c3c34b jmp read ;read disk
4a2a c3d64b jmp write ;write disk
4a2d c34b4b jmp listst ;return list status
4a30 c3a74b jmp sectran ;sector translate
;
; fixed data tables for four-drive standard
; ibm-compatible 8" disks
; disk parameter header for disk 00
4a33 734a00 dpbase: dw trans,0000h
4a37 000000 dw 0000h,0000h
4a3b f04c8d dw dirbf,dpblk
4a3f ec4d70 dw chk00,all00
;
; disk parameter header for disk 01
4a43 734a00 dw trans,0000h
4a47 000000 dw 0000h,0000h
4a4b f04c8d dw dirbf,dpblk
4a4f fc4d8f dw chk01,all01
;
; disk parameter header for disk 02
4a53 734a00 dw trans,0000h
4a57 000000 dw 0000h,0000h
4a5b f04c8d dw dirbf,dpblk
4a5f 0c4eae dw chk02,all02

```

```

; disk parameter header for disk 03
4a63 734a00 dw trans,0000h
4a67 000000 dw 0000h,0000h
4a6b f04c8d dw dirbf,dpblk
4a6f 1c4ecd dw chk03,all03

;
; sector translate vector
4a73 01070d trans: db 1,7,13,19 ;sectors 1,2,3,4
4a77 19050b db 25,5,11,17 ;sectors 5,6,7,8
4a7b 170309 db 23,3,9,15 ;sectors 9,10,11,12
4a7f 150208 db 21,2,8,14 ;sectors 13,14,15,16
4a83 141a06 db 20,26,6,12 ;sectors 17,18,19,20
4a87 121804 db 18,24,4,10 ;sectors 21,22,23,24
4a8b 1016 db 16,22 ;sectors 25,26

;
; dpblk: ;disk parameter block, common to all disks
4a8d 1a00 dw 26 ;sectors per track
4a8f 03 db 3 ;block shift factor
4a90 07 db 7 ;block mask
4a91 00 db 0 ;null mask
4a92 f200 dw 242 ;disk size-1
4a94 3f00 dw 63 ;directory max
4a96 c0 db 192 ;alloc 0
4a97 00 db 0 ;alloc 1
4a98 1000 dw 16 ;check size
4a9a 0200 dw 2 ;track offset

;
; end of fixed tables

;
; individual subroutines to perform each function
boot: ;simplest case is to just perform parameter initi
4a9c af xra a ;zero in the accum
4a9d 320300 sta iobyte ;clear the iobyte
4aa0 320400 sta cdisk ;select disk zero
4aa3 c3ef4a jmp gocpm ;initialize and go to cp/

;
wboot: ;simplest case is to read the disk until all sect
4aa6 318000 lxi sp,80h ;use space below buffer f
4aa9 0e00 mvi c,0 ;select disk 0
4aab cd5a4b call seldsk
4aae cd544b call home ;go to track 00

;
4ab1 062c mvi b,nsects ;b counts # of sectors to
4ab3 0e00 mvi c,0 ;c has the current track
4ab5 1602 mvi d,2 ;d has the next sector to

; note that we begin by reading track 0, sector 2 s
; contains the cold start loader, which is skipped
4ab7 210034 lxi h,ccp ;base of cp/m (initial lo

load1: ;load one more sector
4aba c5 push b ;save sector count, current track
4abb d5 push d ;save next sector to read
4abc e5 push h ;save dma address
4abd 4a mov c,d ;get sector address to register c
4abe cd924b call setsec ;set sector address from register
4acl c1 pop b ;recall dma address to b,c

```

```

4ac2 c5      push    b      ;replace on stack for later recal
4ac3 cdad4b  call    setdma ;set dma address from b,c
;
; drive set to 0, track set, sector set, dma address
4ac6 cdc34b  call    read
4ac9 fe00    cpi     00h    ;any errors?
4acb c2a64a  jnz    wboot  ;retry the entire boot if an erro
;
; no error, move to next sector
4ace e1      pop     h      ;recall dma address
4acf 118000  lxi    d,128  ;dma=dma+128
4ad2 19      dad    d      ;new dma address is in h,1
4ad3 d1      pop     d      ;recall sector address
4ad4 c1      pop     b      ;recall number of sectors remaini
4ad5 05      dcr    b      ;sectors=sectors-1
4ad6 caef4a  jz     gocpm  ;transfer to cp/m if all have bee
;
; more sectors remain to load, check for track chan
4ad9 14      inr    d
4ada 7a      mov    a,d    ;sector=27?, if so, change tracks
4adb felb    cpi    27
4add daba4a jc     loadl  ;carry generated if sector<27
;
; end of current track, go to next track
4ae0 1601    mvi    d,1    ;begin with first sector of next
4ae2 0c      inr    c      ;track=track+1
;
; save register state, and change tracks
4ae3 c5      push   b
4ae4 d5      push   d
4ae5 e5      push   h
4ae6 cd7d4b call   settrk ;track address set from register
4ae9 e1      pop    h
4aea d1      pop    d
4aeb c1      pop    b
4aec c3ba4a jmp    loadl  ;for another sector
;
; end of load operation, set parameters and go to c
gocpm:
4aef 3ec3    mvi    a,0c3h ;c3 is a jmp instruction
4af1 320000  sta    0      ;for jmp to wboot
4af4 21034a  lxi    h,wboote ;wboot entry point
4af7 220100  shld   1      ;set address field for jmp at 0
;
4afa 320500  sta    5      ;for jmp to bdos
4afd 21063c  lxi    h,bdos ;bdos entry point
4b00 220600  shld   6      ;address field of jump at 5 to bd
;
4b03 018000  lxi    b,80h  ;default dma address is 80h
4b06 cdad4b  call   setdma
;
4b09 fb      ei         ;enable the interrupt system
4b0a 3a0400  lda    cdisk  ;get current disk number
4b0d 4f      mov    c,a    ;send to the ccp
4b0e c30034  jmp    ccp    ;go to cp/m for further processin

```



```

;
;
;       simple i/o handlers (must be filled in by user)
;       in each case, the entry point is provided, with s
;       to insert your own code
;
const: ;console status, return 0ffh if character ready,
4b11    ds      10h      ;space for status subroutine
4b21 3e00 mvi      a,00h
4b23 c9   ret

;
conin: ;console character into register a
4b24    ds      10h      ;space for input routine
4b34 e67f ani      7fh      ;strip parity bit
4b36 c9   ret

;
conout: ;console character output from register c
4b37 79   mov      a,c      ;get to accumulator
4b38    ds      10h      ;space for output routine
4b48 c9   ret

;
list: ;list character from register c
4b49 79   mov      a,c      ;character to register a
4b4a c9   ret          ;null subroutine

;
listst: ;return list status (0 if not ready, 1 if ready)
4b4b af   xra      a      ;0 is always ok to return
4b4c c9   ret

;
punch: ;punch character from register c
4b4d 79   mov      a,c      ;character to register a
4b4e c9   ret          ;null subroutine

;
;
reader: ;read character into register a from reader device
4b4f 3ela mvi      a,lah     ;enter end of file for now (repla
4b51 e67f ani      7fh      ;remember to strip parity bit
4b53 c9   ret

;
;
;       i/o drivers for the disk follow
;       for now, we will simply store the parameters away
;       in the read and write subroutines
;
home: ;move to the track 00 position of current drive
;       translate this call into a settrk call with param
4b54 0e00 mvi      c,0      ;select track 0
4b56 cd7d4b call     settrk
4b59 c9   ret          ;we will move to 00 on first read

;
seldsk: ;select disk given by register c
4b5a 210000 lxi     h,0000h ;error return code
4b5d 79   mov      a,c
4b5e 32ef4c sta     diskno
4b61 fe04 cpi      4      ;must be between 0 and 3

```

```

4b63 d0          rnc          ;no carry if 4,5,...
;
4b64            ds          10h    ;space for disk select
;
4b6e 3aef4c     lda          diskno
4b71 6f         mov          l,a    ;l=disk number 0,1,2,3
4b72 2600       mvi          h,0    ;high order zero
4b74 29         dad          h     ;*2
4b75 29         dad          h     ;*4
4b76 29         dad          h     ;*8
4b77 29         dad          h     ;*16 (size of each header)
4b78 11334a     lxi          d,dpbase
4b7b 19         dad          d     ;hl=.dpbase(diskno*16)
4b7c c9         ret
;
; settrk: ;set track given by register c
4b7d 79         mov          a,c
4b7e 32e94c     sta          track
4b81           ds          10h    ;space for track select
4b91 c9         ret
;
; setsec: ;set sector given by register c
4b92 79         mov          a,c
4b93 32eb4c     sta          sector
4b96           ds          10h    ;space for sector select
4ba6 c9         ret
;
; sectran:
; translate the sector given by bc using the
; translate table given by de
4ba7 eb        xchg          ;hl=.trans
4ba8 09        dad          b     ;hl=.trans(sector)
4ba9 6e        mov          l,m    ;l = trans(sector)
4baa 2600       mvi          h,0    ;hl= trans(sector)
4bac c9        ret          ;with value in hl
;
; setdma: ;set dma address given by registers b and c
4bad 69        mov          l,c    ;low order address
4bae 60        mov          h,b    ;high order address
4baf 22ed4c     shld         dmaad    ;save the address
4bb2           ds          10h    ;space for setting the dma address
4bc2 c9        ret
;
; read: ;perform read operation (usually this is similar
; so we will allow space to set up read command, th
; common code in write)
4bc3           ds          10h    ;set up read command
4bd3 c3e64b     jmp          waitio ;to perform the actual i/o
;
; write: ;perform a write operation
4bd6           ds          10h    ;set up write command
;
; waitio: ;enter here from read and write to perform the ac
; operation. return a 00h in register a if the ope
; properly, and 01h if an error occurs during the r

```

```

;
;   in this case, we have saved the disk number in 'd
;   the track number in 'track' (0-76
;   the sector number in 'sector' (1-
;   the dma address in 'dmaad' (0-655
4be6      ds      256      ;space reserved for i/o drivers
4ce6 3e01 mvi      a,1      ;error condition
4ce8 c9    ret          ;replaced when filled-in
;
;   the remainder of the cbios is reserved uninitiali
;   data area, and does not need to be a part of the
;   system memory image (the space must be available,
;   however, between "begdat" and "enddat").
;
4ce9      track: ds      2      ;two bytes for expansion
4ceb      sector: ds     2      ;two bytes for expansion
4ced      dmaad: ds     2      ;direct memory address
4cef      diskno: ds    1      ;disk number 0-15
;
;   scratch ram area for bdos use
4cf0 =    begdat equ     $      ;beginning of data area
4cf0      dirbf: ds    128     ;scratch directory area
4d70      all00: ds    31     ;allocation vector 0
4d8f      all01: ds    31     ;allocation vector 1
4dae      all02: ds    31     ;allocation vector 2
4dcd      all03: ds    31     ;allocation vector 3
4dec      chk00: ds    16     ;check vector 0
4dfc      chk01: ds    16     ;check vector 1
4e0c      chk02: ds    16     ;check vector 2
4e1c      chk03: ds    16     ;check vector 3
;
4e2c =    enddat equ     $      ;end of data area
013c =    datsiz equ    $-begdat;size of data area
4e2c      end

```

APPENDIX D: A SKELETAL GETSYS/PUTSYS PROGRAM

```

;      combined getsys and putsys programs from Sec 4.
;      Start the programs at the base of the TPA

0100          org      0100h

0014 =      msize   equ      20          ; size of cp/m in Kbytes

; "bias" is the amount to add to addresses for > 20k
;      (referred to as "b" throughout the text)

0000 =      bias    equ      (msize-20)*1024
3400 =      ccp     equ      3400h+bias
3c00 =      bdos   equ      ccp+0800h
4a00 =      bios   equ      ccp+1600h

;      getsys programs tracks 0 and 1 to memory at
;      3880h + bias

;      register          usage
;      a                (scratch register)
;      b                track count (0...76)
;      c                sector count (1...26)
;      d,e              (scratch register pair)
;      h,l              load address
;      sp               set to stack address

gstart:
0100 318033   lxi      sp,ccp-0080h   ; start of getsys
0103 218033   lxi      h,ccp-0080h   ; convenient plac
0106 0600     mvi      b,0           ; set initial loa
; start with trac
rd$trk:
0108 0e01     mvi      c,1         ; read next track
; each track star
rd$sec:
010a cd0003   call     read$sec       ; get the next se
010d 118000   lxi      d,128         ; offset by one s
0110 19       dad      d           ; (hl=hl+128)
0111 0c       inr      c           ; next sector
0112 79       mov      a,c         ; fetch sector nu
0113 fe1b     cpi      27          ; and see if la
0115 da0a01   jc       rdsec        ; <, do one more

; arrive here at end of track, move to next track

0118 04       inr      b           ; track = track+1
0119 78       mov      a,b         ; check for last
011a fe02     cpi      2           ; track = 2 ?
011c da0801   jc       rd$trk       ; <, do another

; arrive here at end of load, halt for lack of anything b

011f fb       ei
0120 76       hlt

```

```

;      putsys program, places memory image starting at
;      3880h + bias back to tracks 0 and 1
;      start this program at the next page boundary

0200          org      ($+0100h) and 0ff00h

put$sys:
0200 318033    lxi      sp,ccp-0080h      ; convenient plac
0203 218033    lxi      h,ccp-0080h      ; start of dump
0206 0600      mvi      b,0              ; start with trac
wr$trk:
0208 0e01      mvi      c,1              ; start with sect
wr$sec:
020a cd0004    call     write$sec          ; write one secto
020d 118000    lxi      d,128             ; length of each
0210 19        dad      d              ; <hl>=<hl> + 128
0211 0c        inr     c              ; <c> = <c> + 1
0212 79        mov     a,c            ; see if
0213 felb     cpi     27              ; past end of t
0215 da0a02    jc      wr$sec          ; no, do another

; arrive here at end of track, move to next track

0218 04        inr     b              ; track = track+1
0219 78        mov     a,b            ; see if
021a fe02     cpi     2              ; last track
021c da0802    jc      wr$trk         ; no, do another

; done with putsys, halt for lack of anything bette

021f fb        ei
0220 76        hlt

; user supplied subroutines for sector read and write

; move to next page boundary

0300          org      ($+0100h) and 0ff00h

read$sec:
; read the next sector
; track in <b>,
; sector in <c>
; dmaaddr in <hl>

0300 c5        push     b
0301 e5        push     h

; user defined read operation goes here

0302          ds      64

0342 e1        pop     h
0343 c1        pop     b

```

```

0344 c9          ret
0400          org      ($+0100h) and 0ff00h    ; another page bo
write$sec:
                ; same parameters as read$sec
0400 c5          push   b
0401 e5          push   h
                ; user defined write operation goes here
0402          ds      64
0442 e1          pop    h
0443 c1          pop    b
0444 c9          ret
                ; end of getsys/putsys program
0445          end

```

## APPENDIX E: A SKELETAL COLD START LOADER

```
; this is a sample cold start loader which, when modified
; resides on track 00, sector 01 (the first sector on the
; diskette). we assume that the controller has loaded
; this sector into memory upon system start-up (this pro-
; gram can be keyed-in, or can exist in read/only memory
; beyond the address space of the cp/m version you are
; running). the cold start loader brings the cp/m system
; into memory at "loadp" (3400h + "bias"). in a 20k
; memory system, the value of "bias" is 0000h, with large
; values for increased memory sizes (see section 2). afte
; loading the cp/m system, the cold start loader branches
; to the "boot" entry point of the bios, which begins at
; "bios" + "bias." the cold start loader is not used un-
; til the system is powered up again, as long as the bios
; is not overwritten. the origin is assumed at 0000h, an
; must be changed if the controller brings the cold start
; loader into another area, or if a read/only memory area
; is used.
```

```
0000          org      0          ; base of ram in cp/m

0014 =        msize   equ      20          ; min mem size in kbytes

0000 =        bias    equ      (msize-20)*1024 ; offset from 20k system
3400 =        ccp     equ      3400h+bias   ; base of the ccp
4a00 =        bios    equ      ccp+1600h    ; base of the bios
0300 =        biosl   equ      0300h      ; length of the bios
4a00 =        boot    equ      bios
1900 =        size    equ      bios+biosl-ccp ; size of cp/m system
0032 =        sects   equ      size/128    ; # of sectors to load
```

```
; begin the load operation
```

```
cold:
```

```
0000 010200    lxi      b,2          ; b=0, c=sector 2
0003 1632      mvi      d,sects      ; d=# sectors to load
0005 210034    lxi      h,ccp        ; base transfer address
```

```
lsect: ; load the next sector
```

```
; insert inline code at this point to
; read one 128 byte sector from the
; track given in register b, sector
; given in register c,
; into the address given by <hl>
;
; branch to location "cold" if a read error occurs
```

```

; *****
;
; *          user supplied read operation goes here...
; *
; *****

0008 c36b00      jmp      past$patch      ; remove this when patche
000b              ds      60h

past$patch:
; go to next sector if load is incomplete
006b 15          dcr      d          ; sects=sects-1
006c ca004a      jz       boot           ; head for the bios

;          more sectors to load
;
; we aren't using a stack, so use <sp> as scratch registe
;          to hold the load address increment

006f 318000      lxi     sp,128          ; 128 bytes per sector
0072 39          dad     sp          ; <hl> = <hl> + 128

0073 0c          inr     c          ; sector = sector + 1
0074 79          mov     a,c
0075 felb       cpi     27          ; last sector of track?
0077 da0800      jc      lsect         ; no, go read another

; end of track, increment to next track

007a 0e01        mvi     c,1           ; sector = 1
007c 04          inr     b          ; track = track + 1
007d c30800      jmp     lsect         ; for another group
0080              end     ; of boot loader

```



## APPENDIX F: CP/M DISK DEFINITION LIBRARY

```

1: ;      CP/M 2.0 disk re-definition library
2: ;
3: ;      Copyright (c) 1979
4: ;      Digital Research
5: ;      Box 579
6: ;      Pacific Grove, CA
7: ;      93950
8: ;
9: ;      CP/M logical disk drives are defined using the
10: ;     macros given below, where the sequence of calls
11: ;     is:
12: ;
13: ;     disks      n
14: ;     diskdef parameter-list-0
15: ;     diskdef parameter-list-1
16: ;     ...
17: ;     diskdef parameter-list-n
18: ;     endef
19: ;
20: ;     where n is the number of logical disk drives attached
21: ;     to the CP/M system, and parameter-list-i defines the
22: ;     characteristics of the ith drive (i=0,1,...,n-1)
23: ;
24: ;     each parameter-list-i takes the form
25: ;           dn,fsc,lsc,[skf],bls,dks,dir,cks,ofs,[0]
26: ;     where
27: ;     dn      is the disk number 0,1,...,n-1
28: ;     fsc     is the first sector number (usually 0 or 1)
29: ;     lsc     is the last sector number on a track
30: ;     skf     is optional "skew factor" for sector translate
31: ;     bls     is the data block size (1024,2048,...,16384)
32: ;     dks     is the disk size in bls increments (word)
33: ;     dir     is the number of directory elements (word)
34: ;     cks     is the number of dir elements to checksum
35: ;     ofs     is the number of tracks to skip (word)
36: ;     [0]    is an optional 0 which forces 16K/directory en
37: ;
38: ;     for convenience, the form
39: ;           dn,dm
40: ;     defines disk dn as having the same characteristics as
41: ;     a previously defined disk dm.
42: ;
43: ;     a standard four drive CP/M system is defined by
44: ;           disks      4
45: ;           diskdef 0,1,26,6,1024,243,64,64,2
46: ;     dsk      set      0
47: ;           rept      3
48: ;     dsk      set      dsk+1
49: ;           diskdef %dsk,0
50: ;           endm
51: ;           endef
52: ;
53: ;     the value of "begdat" at the end of assembly defines t

```

```

54: ; beginning of the uninitialize ram area above the bios,
55: ; while the value of "enddat" defines the next location
56: ; following the end of the data area. the size of this
57: ; area is given by the value of "datsiz" at the end of t
58: ; assembly. note that the allocation vector will be qui
59: ; large if a large disk size is defined with a small blo
60: ; size.
61: ;
62: dskhdr macro dn
63: ;; define a single disk header list
64: dpe&dn: dw xlt&dn,0000h ;translate table
65: dw 0000h,0000h ;scratch area
66: dw dirbuf,dpb&dn ;dir buff,param block
67: dw csv&dn,alv&dn ;check, alloc vectors
68: endm
69: ;
70: disks macro nd
71: ;; define nd disks
72: ndisks set nd ;;for later reference
73: dpbase equ $ ;base of disk parameter blocks
74: ;; generate the nd elements
75: dsknxt set 0
76: rept nd
77: dskhdr %dsknxt
78: dsknxt set dsknxc+1
79: endm
80: endm
81: ;
82: dpbhdr macro dn
83: dpb&dn equ $ ;disk parm block
84: endm
85: ;
86: ddb macro data,comment
87: ;; define a db statement
88: db data comment
89: endm
90: ;
91: ddw macro data,comment
92: ;; define a dw statement
93: dw data comment
94: endm
95: ;
96: gcd macro m,n
97: ;; greatest common divisor of m,n
98: ;; produces value gcdn as result
99: ;; (used in sector translate table generation)
100: gcdm set m ;;variable for m
101: gcdn set n ;;variable for n
102: gcdr set 0 ;;variable for r
103: rept 65535
104: gcdx set gcdm/gcdn
105: gcdr set gcdm - gcdx*gcdn
106: if gcdr = 0
107: exitm
108: endif

```

```

109: gcdm      set      gcdn
110: gcdn      set      gcdr
111:           endm
112:           endm
113: ;
114: diskdef macro  dn,fsc,lsc,skf,bls,dks,dir,cks,bfs,kl6
115: ;;         generate the set statements for later tables
116:           if      nul lsc
117: ;;         current disk dn same as previous fsc
118: dpb&dn     equ      dpb&fsc ;equivalent parameters
119: als&dn     equ      als&fsc ;same allocation vector size
120: css&dn     equ      css&fsc ;same checksum vector size
121: xlt&dn     equ      xlt&fsc ;same translate table
122:           else
123: secmax     set      lsc-(fsc)      ;;sectors 0...secmax
124: sectors    set      secmax+1;;number of sectors
125: als&dn     set      (dks)/8      ;;size of allocation vector
126:           if      ((dks) mod 8) ne 0
127: als&dn     set      als&dn+1
128:           endif
129: css&dn     set      (cks)/4      ;;number of checksum elements
130: ;;         generate the block shift value
131: blkval     set      bls/128      ;;number of sectors/block
132: blkshf     set      0            ;;counts right 0's in blkval
133: blkmsk     set      0            ;;fills with 1's from right
134:           rept    16            ;;once for each bit position
135:           if      blkval=1
136:           exitm
137:           endif
138: ;;         otherwise, high order 1 not found yet
139: blkshf     set      blkshf+1
140: blkmsk     set      (blkmsk shl 1) or 1
141: blkval     set      blkval/2
142:           endm
143: ;;         generate the extent mask byte
144: blkval     set      bls/1024      ;;number of kilobytes/block
145: extmsk     set      0            ;;fill from right with 1's
146:           rept    16
147:           if      blkval=1
148:           exitm
149:           endif
150: ;;         otherwise more to shift
151: extmsk     set      (extmsk shl 1) or 1
152: blkval     set      blkval/2
153:           endm
154: ;;         may be double byte allocation
155:           if      (dks) > 256
156: extmsk     set      (extmsk shr 1)
157:           endif
158: ;;         may be optional [0] in last position
159:           if      not nul kl6
160: extmsk     set      kl6
161:           endif
162: ;;         now generate directory reservation bit vector
163: dirrem     set      dir          ;;# remaining to process

```

```

164: dirbks set bls/32 ;;number of entries per block
165: dirblk set 0 ;;fill with 1's on each loop
166: rept 16
167: if dirrem=0
168: exitm
169: endif
170: ;; not complete, iterate once again
171: ;; shift right and add 1 high order bit
172: dirblk set (dirblk shr 1) or 8000h
173: if dirrem > dirbks
174: dirrem set dirrem-dirbks
175: else
176: dirrem set 0
177: endif
178: endm
179: dpbhdr dn ;;generate equ $
180: ddw %sectors,<;sec per track>
181: ddb %blkshf,<;block shift>
182: ddb %blkmsk,<;block mask>
183: ddb %extmsk,<;extnt mask>
184: ddw %(dks)-1,<;disk size-1>
185: ddw %(dir)-1,<;directory max>
186: ddb %dirblk shr 8,<;alloc0>
187: ddb %dirblk and 0ffh,<;alloc1>
188: ddw %(cks)/4,<;check size>
189: ddw %ofs,<;offset>
190: ;; generate the translate table, if requested
191: if nul skf
192: xlt&dn equ 0 ;no xlate table
193: else
194: if skf = 0
195: xlt&dn equ 0 ;no xlate table
196: else
197: ;; generate the translate table
198: nxtsec set 0 ;;next sector to fill
199: nxtbas set 0 ;;mcves by one on overflow
200: gcd %sectors,skf
201: ;; gcdn = gcd(sectors,skew)
202: neltst set sectors/gcdn
203: ;; neltst is number of elements to generate
204: ;; before we overlap previous elements
205: nelts set neltst ;;counter
206: xlt&dn equ $ ;translate table
207: rept sectors ;;once for each sector
208: if sectors < 256
209: ddb %nxtsec+(fsc)
210: else
211: ddw %nxtsec+(fsc)
212: endif
213: nxtsec set nxtsec+(skf)
214: if nxtsec >= sectors
215: nxtsec set nxtsec-sectors
216: endif
217: nelts set nelts-1
218: if nelts = 0

```

```

219: nxtbas set      nxtbas+i
220: nxtsec set      nxtbas
221: nelts  set      neltst
222:        endif
223:        endm
224:        endif    ;;end of nul fac test
225:        endif    ;;end of nul bls test
226:        endm
227: ;
228: defds  macro    lab,space
229: lab:   ds        space
230:        endm
231: ;
232: lds    macro    lb,dn,val
233:        defds    lb&dn,%val&dn
234:        endm
235: ;
236: endef  macro
237: ;; generate the necessary ram data areas
238: begdat equ      $
239: dirbuf: ds      128      ;directory access buffer
240: dsknxt set      0
241:        rept    ndisks ;;once for each disk
242:        lds    alv,%dsknxt,als
243:        lds    csv,%dsknxt,css
244: dsknxt set      dsknxt+1
245:        endm
246: enddat equ      $
247: datsiz equ      $-begdat
248: ;; db 0 at this point forces hex record
249:        endm

```

APPENDIX G: BLOCKING AND DEBLOCKING ALGORITHMS.

```

1: ;*****
2: ;*
3: ;*      Sector Deblocking Algorithms for CP/M 2.0      *
4: ;*
5: ;*****
6: ;
7: ;      utility macro to compute sector mask
8: smask  macro  hblk
9: ;;      compute log2(hblk), return @x as result
10: ;;      (2 ** @x = hblk on return)
11: @y      set    hblk
12: @x      set    0
13: ;;      count right shifts of @y until = 1
14:      rept  8
15:      if    @y = 1
16:      exitm
17:      endif
18: ;;      @y is not 1, shift right one position
19: @y      set    @y shr 1
20: @x      set    @x + 1
21:      endm
22:      endm
23: ;
24: ;*****
25: ;*
26: ;*      CP/M to host disk constants
27: ;*
28: ;*****
29: blksize equ    2048          ;CP/M allocation size
30: hstsiz  equ    512          ;host disk sector size
31: hstspt  equ    20           ;host disk sectors/trk
32: hstblk  equ    hstsiz/128   ;CP/M sects/host buff
33: cpmspt  equ    hstblk * hstspt ;CP/M sectors/track
34: secmsk  equ    hstblk-1     ;sector mask
35:      smask  hstblk          ;compute sector mask
36: secshf  equ    @x           ;log2(hstblk)
37: ;
38: ;*****
39: ;*
40: ;*      BDOS constants on entry to write
41: ;*
42: ;*****
43: wrall   equ    0            ;write to allocated
44: wrdir   equ    1            ;write to directory
45: wrual   equ    2            ;write to unallocated
46: ;
47: ;*****
48: ;*
49: ;*      The BDOS entry points given below show the
50: ;*      code which is relevant to deblocking only.
51: ;*
52: ;*****
53: ;

```

```

54: ;          DISKDEF macro, or hand coded tables go here
55: dpbase   equ      $          ;disk param block base
56: ;
57: boot:
58: wboot:
59:          ;enter here on system boot to initialize
60:      xra      a          ;0 to accumulator
61:      sta      hstact     ;host buffer inactive
62:      sta      unacnt     ;clear unalloc count
63:      ret
64: ;
65: seldsk:
66:          ;select disk
67:      mov      a,c          ;selected disk number
68:      sta      sekdisk    ;seek disk number
69:      mov      l,a          ;disk number to HL
70:      mvi      h,0
71:      rept     4          ;multiply by 16
72:      dad      h
73:      endm
74:      lxi      d,dpbase    ;base of parm block
75:      dad      d          ;hl=.dpb(curdisk)
76:      ret
77: ;
78: settrk:
79:          ;set track given by registers BC
80:      mov      h,b
81:      mov      l,c
82:      shld     sektrk     ;track to seek
83:      ret
84: ;
85: setsec:
86:          ;set sector given by register c
87:      mov      a,c
88:      sta      seksec     ;sector to seek
89:      ret
90: ;
91: setdma:
92:          ;set dma address given by BC
93:      mov      h,b
94:      mov      l,c
95:      shld     dmaadr
96:      ret
97: ;
98: sectran:
99:          ;translate sector number BC
100:     mov      h,b
101:     mov      l,c
102:     ret
103: ;

```

```

104: ;*****
105: ;*
106: ;*   The READ entry point takes the place of
107: ;*   the previous BIOS definition for READ.
108: ;*
109: ;*****
110: read:
111:     ;read the selected CP/M sector
112:     mvi     a,l
113:     sta     readop           ;read operation
114:     sta     rsflag         ;must read data
115:     mvi     a,wrual
116:     sta     wrtype         ;treat as unalloc
117:     jmp     rwoper         ;to perform the read
118: ;
119: ;*****
120: ;*
121: ;*   The WRITE entry point takes the place of
122: ;*   the previous BIOS definition for WRITE.
123: ;*
124: ;*****
125: write:
126:     ;write the selected CP/M sector
127:     xra     a               ;0 to accumulator
128:     sta     readop         ;not a read operation
129:     mov     a,c             ;write type in c
130:     sta     wrtype
131:     cpi     wrual          ;write unallocated?
132:     jnz     chkuna         ;check for unalloc
133: ;
134: ;   write to unallocated, set parameters
135:     mvi     a,blksiz/128   ;next unalloc recs
136:     sta     unacnt
137:     lda     sekdisk        ;disk to seek
138:     sta     unadsk        ;unadsk = sekdisk
139:     lhld   sektrk
140:     shld   unatrck        ;unatrck = sectrk
141:     lda     seksec
142:     sta     unasec        ;unasec = seksec
143: ;
144: chkuna:
145:     ;check for write to unallocated sector
146:     lda     unacnt         ;any unalloc remain?
147:     ora     a
148:     jz     alloc          ;skip if not
149: ;
150: ;   more unallocated records remain
151:     dcr     a               ;unacnt = unacnt-1
152:     sta     unacnt
153:     lda     sekdisk        ;same disk?
154:     lxi     h,unadsk
155:     cmp    m               ;sekdisk = unadsk?
156:     jnz    alloc          ;skip if not
157: ;
158: ;   disks are the same

```



```

159:      lxi      h,unatrck
160:      call     sektrkcmp      ;sektrk = unatrck?
161:      jnz      alloc          ;skip if not
162: ;
163: ;      tracks are the same
164:      lda      seksec          ;same sector?
165:      lxi      h,unasec
166:      cmp      m              ;seksec = unasec?
167:      jnz      alloc          ;skip if not
168: ;
169: ;      match, move to next sector for future ref
170:      inr      m              ;unasec = unasec+1
171:      mov      a,m            ;end of track?
172:      cpi      cpmspt         ;count CP/M sectors
173:      jc       noovf          ;skip if no overflow
174: ;
175: ;      overflow to next track
176:      mvi      m,0            ;unasec = 0
177:      lhld     unatrck
178:      inx      h
179:      shld     unatrck        ;unatrck = unatrck+1
180: ;
181: noovf:
182:      ;match found, mark as unnecessary read
183:      xra      a              ;0 to accumulator
184:      sta      rsflag         ;rsflag = 0
185:      jmp      rwoper         ;to perform the write
186: ;
187: alloc:
188:      ;not an unallocated record, requires pre-read
189:      xra      a              ;0 to accum
190:      sta      unacnt         ;unacnt = 0
191:      inr      a              ;1 to accum
192:      sta      rsflag         ;rsflag = 1
193: ;
194: ;*****
195: ;*
196: ;*      Common code for READ and WRITE follows      *
197: ;*
198: ;*****
199: rwoper:
200:      ;enter here to perform the read/write
201:      xra      a              ;zero to accum
202:      sta      erflag         ;no errors (yet)
203:      lda      seksec          ;compute host sector
204:      rept     secshf
205:      ora      a              ;carry = 0
206:      rar      ;shift right
207:      endm
208:      sta      sekhst         ;host sector to seek
209: ;
210: ;      active host sector?
211:      lxi      h,hstact       ;host active flag
212:      mov      a,m
213:      mvi      m,1           ;always becomes 1

```

```

214:          ora      a              ;was it already?
215:          jz       filhst         ;fill host if not
216: ;
217: ;          host buffer active, same as seek buffer?
218:          lda      sekdisk
219:          lxi      h,hstdsk        ;same disk?
220:          cmp      m              ;sekdisk = hstdsk?
221:          jnz      nomatch
222: ;
223: ;          same disk, same track?
224:          lxi      h,hsttrk
225:          call     sektrkcmp        ;sektrk = hsttrk?
226:          jnz      nomatch
227: ;
228: ;          same disk, same track, same buffer?
229:          lda      sekhst
230:          lxi      h,hstsec        ;sekhst = hstsec?
231:          cmp      m
232:          jz       match           ;skip if match
233: ;
234: nomatch:
235:          ;proper disk, but not correct sector
236:          lda      hstwrtr         ;host written?
237:          ora      a
238:          cnz      writehst        ;clear host buff
239: ;
240: filhst:
241:          ;may have to fill the host buffer
242:          lda      sekdisk
243:          sta      hstdsk
244:          lhd     sektrk
245:          shld    hsttrk
246:          lda      sekhst
247:          sta      hstsec
248:          lda      rsflag          ;need to read?
249:          ora      a
250:          cnz      readhst         ;yes, if 1
251:          xra     a                ;0 to accum
252:          sta     hstwrtr         ;no pending write
253: ;
254: match:
255:          ;copy data to or from buffer
256:          lda      seksec          ;mask buffer number
257:          ani     secmsk          ;least signif bits
258:          mov     l,a              ;ready to shift
259:          mvi     h,0              ;double count
260:          rept   7                 ;shift left 7
261:          dad     h
262:          endm
263: ;          hl has relative host buffer address
264:          lxi     d,hstbuf
265:          dad     d                ;hl = host address
266:          xchg
267:          lhd     dmaadr           ;now in DE
268:          mvi     c,128           ;get/put CP/M data
                                   ;length of move

```

```

269:      lda      readop          ;which way?
270:      ora      a
271:      jnz      rwmov          ;skip if read
272: ;
273: ;      write operation, mark and switch direction
274:      mvi      a,l
275:      sta      hstwr          ;hstwr = 1
276:      xchg     ;source/dest swap
277: ;
278: rwmov:
279:      ;C initially 128, DE is source, HL is dest
280:      ldax    d                ;source character
281:      inx     d
282:      mov     m,a              ;to dest
283:      inx     h
284:      dcr    c                ;loop 128 times
285:      jnz    rwmov
286: ;
287: ;      data has been moved to/from host buffer
288:      lda     wrtype           ;write type
289:      cpi    wrdir            ;to directory?
290:      lda     erflag          ;in case of errors
291:      rnz    ;no further processing
292: ;
293: ;      clear host buffer for directory write
294:      ora     a                ;errors?
295:      rnz    ;skip if so
296:      xra    a                ;0 to accum
297:      sta    hstwr           ;buffer written
298:      call   writehst
299:      lda    erflag
300:      ret
301: ;
302: ;*****
303: ;*
304: ;*      Utility subroutine for 16-bit compare
305: ;*
306: ;*****
307: sektrkcmp:
308:      ;HL = .unatrkr or .hsttrkr, compare with sektrk
309:      xchg
310:      lxi    h,sektrk
311:      ldax  d                ;low byte compare
312:      cmp   m                ;same?
313:      rnz   ;return if not
314: ;      low bytes equal, test high 1s
315:      inx   d
316:      inx   h
317:      ldax  d
318:      cmp   m                ;sets flags
319:      ret
320: ;

```

```

321: ;*****
322: ;*
323: ;*      WRITEHST performs the physical write to      *
324: ;*      the host disk, READHST reads the physical    *
325: ;*      disk.                                         *
326: ;*
327: ;*****
328: writehst:
329:       ;hstdsk = host disk #, hsttrk = host track #,
330:       ;hstsec = host sect #. write "hstsiz" bytes
331:       ;from hstbuf and return error flag in erflag.
332:       ;return erflag non-zero if error
333:       ret
334: ;
335: readhst:
336:       ;hstdsk = host disk #, hsttrk = host track #,
337:       ;hstsec = host sect #. read "hstsiz" bytes
338:       ;into hstbuf and return error flag in erflag.
339:       ret
340: ;
341: ;*****
342: ;*
343: ;*      Unitialized RAM data areas                    *
344: ;*
345: ;*****
346: ;
347: sekdisk: ds      1          ;seek disk number
348: sektrk:  ds      2          ;seek track number
349: seksec:  ds      1          ;seek sector number
350: ;
351: hstdsk:  ds      1          ;host disk number
352: hsttrk:  ds      2          ;host track number
353: hstsec:  ds      1          ;host sector number
354: ;
355: sekhst:  ds      1          ;seek shr secshf
356: hstact:  ds      1          ;host active flag
357: hstwrt:  ds      1          ;host written flag
358: ;
359: unacct:  ds      1          ;unalloc rec cnt
360: unadsk:  ds      1          ;last unalloc disk
361: unatrk:  ds      2          ;last unalloc track
362: unasec:  ds      1          ;last unalloc sector
363: ;
364: erflag:  ds      1          ;error reporting
365: rsflag:  ds      1          ;read sector flag
366: readop:  ds      1          ;1 if read operation
367: wrtype:  ds      1          ;write operation type
368: dmaadr:  ds      2          ;last dma address
369: hstbuf:  ds      hstsiz    ;host buffer
370: ;

```

EXIDY SYSTEMS' CBIOS USERS GUIDE

VERSION 1.0  
FOR  
CP/M 2.2

COPYRIGHT (C) 1981

EXIDY SYSTEMS, INC.

AUGUST 1981

## COPYRIGHT

Copyright (c) 1980 by Exidy Systems, Inc. All rights reserved. No part of this publication may be reproduced, transmitted, transcribed, stored in a retrieval system, or translated into any language, in any form or by any means, electronic, mechanical, magnetic, optical, chemical, manual, or otherwise, without the prior written permission of Exidy Systems, Inc., 1234 Elko Drive, Sunnyvale, California 94086.

Since this manual is tutorial in nature, permission is granted to reproduce or abstract the example procedures and sample programs for the purposes of inclusion within the reader's programs.

## DISCLAIMER

Exidy Systems, Inc. makes no representations or warranties with respect to the contents hereof and specifically disclaims any implied warranties of merchantability or fitness for any particular purpose. Further, Exidy Systems, Inc. reserves the right to revise this publication and to make changes from time to time in the content hereof without obligation of Exidy Systems, Inc. to notify any person of such revision or changes.

## TRADEMARKS

CP/M is a registered trademark of Digital Research.

EXIDY SYSTEMS' CBIOS USERS GUIDE

VERSION 1.0  
FOR  
CP/M 2.2

COPYRIGHT (C) 1981  
EXIDY SYSTEMS, INC.

AUGUST 1981

## COPYRIGHT

Copyright (c) 1980 by Exidy Systems, Inc. All rights reserved. No part of this publication may be reproduced, transmitted, transcribed, stored in a retrieval system, or translated into any language, in any form or by any means, electronic, mechanical, magnetic, optical, chemical, manual, or otherwise, without the prior written permission of Exidy Systems, Inc., 1234 Elko Drive, Sunnyvale, California 94086.

Since this manual is tutorial in nature, permission is granted to reproduce or abstract the example procedures and sample programs for the purposes of inclusion within the reader's programs.

## DISCLAIMER

Exidy Systems, Inc. makes no representations or warranties with respect to the contents hereof and specifically disclaims any implied warranties of merchantability or fitness for any particular purpose. Further, Exidy Systems, Inc. reserves the right to revise this publication and to make changes from time to time in the content hereof without obligation of Exidy Systems, Inc. to notify any person of such revision or changes.

## TRADEMARKS

CP/M is a registered trademark of Digital Research.



## Table Of Contents

### Exidy Systems' CBIOS User's Guide: Version 1.0 For CP/M 2.2

1.	Introduction.....	249
2.	Configuration and System Generation.....	251
	A. Hardware for the DDS and the FDS.....	251
	B. System Generation.....	252
	C. Options.....	253
	D. Incompatibilities.....	254
	E. Sector Skew Pattern.....	254
	F. Special Video Display Interface.....	255
3.	Features.....	256
	A. Error Recovery.....	256
	B. CP/M Programming.....	257
4.	Error Messages.....	259



## 1. INTRODUCTION

The CBIOS program provides the interface between CP/M (TM) and the Sorcerer's hardware. The term BIOS was coined by Digital Research, the creators of CP/M. Their term CBIOS stands for Customized Basic Input/Output System, in which the BIOS is customized to the user's hardware. The Exidy program is a CBIOS in this sense.

Portability is the most valuable attribute of CP/M. The clean separation of logical and physical I/O enables it to run on many 8080/280 based systems. Digital Research provides the logical I/O in CP/M's Basic Disk Operating System (BDOS). This routes all physical I/O through a BIOS vector. See the "CP/M System Alteration Guide" for a description of the BIOS vector and its functions.

Each hardware system CP/M is used on requires a separate BIOS program. The Exidy interface is tailored for the Sorcerer and the hardware the Sorcerer supports. Because the disk drive is the most complicated piece of hardware CP/M uses, this document focuses on the CBIOS disk interface for the Display Disk System (DDS) double sided drives for soft-sectored 77 track diskettes and the Floppy Disk System (FDS) single sided drives for soft-sectored 77 track diskettes.

For clarification, a brief explanation of physical and logical units may benefit the user in our discussion. A physical unit is the actual input/output device and its hardware recording medium. A diskette, for example, physically has 77 tracks, each of which has 16 sectors of 256-bytes. However, an interface between the physical hardware and the user may translate or break up this size into any number of combinations. This level, used by the programmer, is the logical level. That is, the very same diskette may be dealt with by the programmer as a different size from the physical size (say, 77 tracks each of which has 32 sectors of 128-bytes) The software interface makes all necessary adjustments for the input to be understood on the differing physical diskette size.

The Digital Research interface of the BDOS to the BIOS defines the logical CP/M diskette with a logical sector size of 128-bytes. The Exidy physical diskette systems, however, have a 256-byte sector. To compensate for this difference, Exidy splits each physical 256-byte sector in half to form two CP/M logical 128-byte sectors. The CBIOS is responsible for mapping 128-byte logical CP/M sectors to the proper half of a 256-byte physical sector. The physical sectors are skewed or interleaved on the diskette to minimize rotational delay. This skewing pattern is described in detail later.



The disk buffer cache improves performance by buffering reads and writes of the disk in a RAM cache storage area. When CP/M requests a 128-byte sector read from a sector not within the cache buffer, a 256-byte sector from disk must be read. Thus, the cache returns the requested sector to the user, keeping track of the other 128-byte sector half within the 256-byte cache buffer. Should a read request be made for that sector at this point, no disk I/O is required because the sector already exists in the memory cache. This same principle applies to cache buffer writing. That is, only one 256-byte physical sector I/O is written for two CP/M 128-byte logical I/O requests on the same physical sector.

## 2. CONFIGURATION AND SYSTEM GENERATION

### A. Hardware for the DDS and the FDS

The Exidy CBIOS runs on both the Display Disk System (DDS) and the Floppy Disk Subsystem (FDS). A DDS consists of a Sorcerer II Computer (with keyboard), Display Disk Unit containing a video screen, and two soft sectored Micropolis drives. The Exidy CBIOS may actually support three disk drives connected to the soft sectored disk controller. However, a controller and only two drives are supplied with the DDS. The DDS may be augmented by other peripherals such as a printer, cassettes, etc.. The Exidy CBIOS assigns the logical CP/M devices, Punch and Reader, to serial write and serial read respectively. The List device is assigned to the Sorcerer Centronics parallel printer interface.

On cold boot, CP/M on the DDS outputs one of the following messages:

```
CP/M on the Exidy Sorcerer for 77 Track Disk
77 Track Single Sided Disks
32K CP/M VERS 2.2/1F
Copyright (C) 1981 Exidy Systems, Inc.
```

A>

or

```
CP/M on the Exidy System 80
77 Track Double Sided Disks
32K CP/M VERS 2.2/2F
Copyright (c) 1981 Exidy Systems, Inc.
```

A>

The Exidy CBIOS also runs on the Floppy Disk System (FDS). An FDS consists of a Sorcerer II Computer (with keyboard), and a Floppy Disk Subsystem containing an MPI floppy disk drive and controller. The Exidy CBIOS may actually support three disk drives connected to the soft sectored disk controller. However, a controller and only one drive are supplied with the standard Floppy Disk Subsystem. The FDS may be augmented by other peripherals such as printers, cassettes, etc.. The Exidy CBIOS assigns the logical CP/M devices Punch and Reader, to serial write and serial read respectively. The List device is assigned to the Sorcerer Centronics parallel printer interface.

Version 2.2/1F CBIOS operates on the FDS and Version 2.2/2F operates on the DDS.

## B. System Generation

Two programs, MOVCPM and SYSGEN, either create a new CP/M system or change its location in RAM. The MOVCPM program obtains a CP/M system image sized appropriately, for example, 32K, 48K, etc. and performs system relocation. SYSGEN takes the system output from MOVCPM and writes it to tracks 0 and 1 of the target diskette. The simplest method of doing this is:

```
A> MOVCPM 32 * <carriage return>
MOVCPM PROGRAM VERSION 2.0
CONSTRUCTING 32K CP/M VERS 2.2
READY FOR "SYSGEN" OR
"SAVE 40 CPM32.COM"
A>
```

Notice that "MOVCPM 32 \*" is the only user input. At this point MOVCPM has created a 32K CP/M system image in memory and the user may either proceed immediately to SYSGEN or he may save the image on disk as a COM file by typing SAVE 40 CPM32.COM <carriage return> in response to the "A" prompt. The latter procedure provides the user the option of modification with the DDT utility.

With a MOVCPM image in memory, as it is after the last prompt, the user may do a memory image SYSGEN. In the next example, the system is created on drive B. Note the response to the source drive name prompt is a carriage return. This indicates the source system already exists in memory.

```
A>SYSGEN <carriage return>
SYSGEN VER 2.0

SOURCE DRIVE NAME (OR RETURN TO SKIP) <carriage return>
DESTINATION DRIVE NAME (OR RETURN TO REBOOT)B
DESTINATION ON B, THEN TYPE RETURN <carriage return>
```

The actual disk writing occurs and when complete this message signs on:

```
FUNCTION COMPLETE
DESTINATION DRIVE NAME (OR RETURN TO REBOOT)
```

At this point the system has been created on disk. The user should do a cold boot (RESET) on the new diskette (after placing it in drive A) to verify this. For more details on MOVCPM and SYSGEN, see "An Introduction to CP/M Features and Facilities."

MOVCPM may also be performed without the second "\*" parameter MOVCPM 29. In this case, MOVCPM attempts to create and execute in memory a new system of the specified size. However, the system may be destroyed if the given memory size causes the new target system to use memory in either the executing MOVCPM program or the executing CP/M system. Exidy suggests always specifying the second "\*" parameter for MOVCPM and using SYSGEN to create a new disk system.

### C. Options

Two options come with the CBIOS: Diagnostic Error Messages and Read After Write Data Verification. The default settings are 1) no Diagnostic Error Messages and 2) Read After Write Verification.

With the Diagnostic Error Message option turned off, only fatal errors are reported to the user and recovered soft errors are not. The user selects this option if he wants all errors reported. A Diagnostic Error message shows for any error encountered.

The Read After Write Verification option allows all data to be reread and compared to the write buffer and CRC after the user has written to a physical disk sector. The user may turn off this option, increasing the speed of disk writes by 50 per cent. This may, however, decrease data reliability. We suggest leaving this option set to the default value to assure disk writes are being done successfully.

Only someone familiar with CP/M programming should attempt changing option values. To make these changes, the user creates a disk file with his CP/M system on it. That is, he does a MOVCPM, followed by a SAVE, as described in Section 2.B of this manual. The user

then DDT's the CP/M system into memory, altering the contents of absolute location 1F02 hex to reflect the options he wishes, as shown below:

bit 0 = Read After Write Option (hex 01)  
bit 2 = Diagnostic Error Message Option (hex 04)

If the value of the bit is 1, then the option is asserted. A bit of 0 turns off the option. Thus the default value is 01 hex for the Read After Write option without Diagnostic Error Messages.



#### D. Incompatibilities

Some CP/M disk formats, including Exidy's, are incompatible with other CP/M formats. All disk formats, are incompatible with the Micropolis Disk Operating System (MDOS). This incompatibility, especially evident with MDOS, is a result of different sector skewing arrangements. All Exidy disk-based software products only run on Exidy's CP/M(TM).

The Exidy skewing pattern for the FDS version follows for those interested in developing translation programs. The DDS version has a one-for-one sector correspondence and therefore no skewing.

#### E. Sector Skew Pattern

CP/M logical 128-byte sector	Exidy 256-byte Sector (Physical Sector, first/last half)
1	16, first
2	16, last
3	13, first
4	13, last
5	10, first
6	10, last
7	7, first
8	7, last
9	4, first
10	4, last
11	1, first
12	1, last
13	14, first
14	14, last
15	11, first
16	11, last
17	8, first
18	8, last
19	5, first
20	5, last
21	2, first
22	2, last
23	15, first
24	15, last
25	12, first
26	12, last
27	9, first
28	9, last
29	6, first
30	6, last
31	3, first
32	3, last

Note that Exidy physical sectors are numbered 1 to 16, and are 256 physical bytes long. CP/M logical sectors are numbered 1-32 and are 128-bytes long. Thus, two CP/M sectors fit in one Exidy physical sector.

#### F. Special Video Display Interface

The video display on the Sorcerer\ II is a memory mapped device which is not standard with any other on the market. CBIOS supports the following TTY interface for standardized full screen operations.

	<u>HEX</u>	<u>RESULT</u>
Form Feed	(0C)	Clear screen, home cursor
Clear Screen	(1A)	Same as above
Home Cursor	(1E)	Place cursor at row 0, col 0

#### Direct Cursor Addressing:

ESC "=" Row Column  
(1B) (3D) Row/1-29 + 31(1F) Col/1-64 + 31(1F)

Using the above cursor addressing information the following sequence will position the cursor at row 1, col 2:

ESC "=" 32(20) 33(21)

### 3. FEATURES

#### A. Error Recovery

The CBIOS includes extensive automatic error detection, recovery, and reporting facilities. The Read After Write option, active by default, is the only error detection function controlled by the user. When a disk I/O error occurs, recovery is fully automatic in the following steps:

1. CBIOS retries operation up to 5 times until successful.
2. If the error still exists, it steps one track in/out alternately for a total of 6 times and repeats step 1 again.
3. If error still exists, then it deselected/reselects drive and then homes to track 0, up to 2 times, repeating 1 and 2. If error still exists, the error is treated as "permanent" and unrecoverable and the operation is aborted.

These error recovery steps are performed in nested fashion. That is, a separate counter is maintained for each error retry state, 1, 2, and 3. If step 1 fails, (its counter reaching 5), then step 2 is performed and its counter incremented. Meanwhile, the step 1 counter is reset, and its process again performed. If successive errors cause the step 2 counter to reach its maximum, then step 3 is performed, and its counter incremented. Both the first and second counters are reset, and step 1 is reinitiated. Thus a total of sixty (5x6x2) retry steps are performed before the error is declared non-recoverable. This retry process can take up to 75 seconds.

If the error is non-recoverable, the CBIOS issues an error message stating:

```
n DRV: ERR CODE= D
```

n here identifies the drive A, B, or C. Further identification of the error code follows the message.

The CBIOS then returns the error to its caller, the CP/M Basic Disk Operating System (BDOS). BDOS reports the error to the user, in less descriptive terms than the CBIOS in the following message:

```
BDOS ERR ON n: BAD SECTOR
```

The BDOS operation is suspended until the user hits any key except control-C. When any other key is hit, the BDOS retries the I/O. If the user wishes to end error processing, he must hit control-C or reset to the Sorcerer Monitor and perform either a warm boot (GO Ø) or a cold boot.

If the user chooses the Diagnostic Error Message option, each error issues an I/O error message even if recovered by the CBIOS. In the event of a nonrecoverable error, the CBIOS prints 6Ø diagnostic error messages before declaring the error nonrecoverable and issuing the above error message. This procedure slows down recovery considerably. Only technicians diagnosing disk-related hardware errors should use this option.

One peculiar "error" of CP/M systems is the write protect error. The CBIOS shows this error message to the user:

n DRV: ERR CODE=B

However, the CBIOS doesn't report the error to the BDOS. Thus the BDOS thinks it is writing to a disk, but cannot because it is a write protected disk. The BDOS discovers the error only after it reads back the directory data and it does not agree with what it remembered having "written". This usually results in the following error message:

BDOS ERR ON n: R/O

The write protect error occurs when CP/M performs "token" directory writes upon reading each new extent of a file. Thus if a PIP (Peripheral Interchange Program) is performed on a large (>16K) file from a write protected diskette to a writable diskette, the token directory writes cause write protect errors on the write protected source diskette. If the CBIOS returned the write protect error to the BDOS, the user could never copy files from a write protected diskette (even though only reads are to be done). These write protect errors on a diskette used only for input can be ignored as a peculiarity in CP/M.

## B. CP/M Programming

Cache BIOS does not immediately, upon user request, execute disk writes. At any given moment there may be "dirty" buffers in the cache, that is, buffers which should be written to disk. Writing such buffers to disk is called "flushing the cache". The typical user who interfaces to the CBIOS through the BDOS, that is, does

logical file I/O, documented in the "Interface Guide", does not need to be aware of the flushing mechanism. The cache is automatically flushed upon BDOS file closing. Only the user who performs direct CBIOS I/O through the vector needs to be aware of cache flushing. The cache is flushed when:

1. Console output
2. A write to the directory track occurs
3. A CBIOS disk select occurs
4. Warm Boot

Programmers using the non-standard CBIOS I/O functions and not the standard BDOS ones should be careful and account for caching processes.

The best guide to CP/M programming is Digital Research's "CP/M Interface Guide." Although the guide is accurate and informative, additional information may help the user overcome any problems he may encounter, as listed below.

1. The BDOS search commands (function numbers 17 and 18) do not work as indicated in the "CP/M Interface Guide". The following provides accurate information

- a. The Search command (17) does not return a byte pointer. Instead, it returns the index of the found file (within the directory) to register A, or to 255 if a match is not found. The index of the file is within the range of 0 to 127, since the Exidy CP/M contains up to 128 directory entries. Directory entries are 32 bytes per entry, thus there are four entries per sector. The BDOS, searching for the desired file, reads directory sectors into its DMA buffer, located from 80 to FF hex. These facts provide the basis for the following formula. The File Control Block (FCB) for the found file is located at:

$$80H + \text{MOD}(\text{index}, 4) * 32$$

The BDOS returns "index" and MOD is the modulus function which returns the remainder of "index" divided by 4.

- b. Only after the initial search (17), may search (18) occur. The Interface Guide incorrectly states that an FCB parameter is required. Actually, the FDB from the previous search call (17) is used. The parameter returns in the A register and is a directory index exactly as described above in 1a.

#### 4. ERROR MESSAGES

The following is the error message format with an explanation of the various error codes:

x DRV: ERR CODE=c

where x represents the drive on which the error occurred (A, B, or C) and c represents one of the following:

A - Disk Select Error- The disk selected was not drive "A", "B", or "C".

B - Write Protect Error- The attempt to write to a write protected diskette was not reported to the BDOS as an error. See Section 3.B., CP/M Programming.

C - Disk Track Out of Range- A track number was detected past the end of the disk, indicating that the CP/M is very sick.

D - Non-Recoverable Disk I/O Error- All retries have failed to eliminate a read or write error. A more complete description follows this section.

E - Insufficient Memory for Disk Cache Buffers- At initialization, cache buffers are allocated. This error occurs if there is not sufficient space for one cache buffer.

F - Error on Cache Flush- An error occurred while the cache was flushed. The last CP/M job or command should be redone.

A non-recoverable disk I/O error (Code D) has a few possible causes, which is one of the following:

(I/O Type):TRK=ttH, SCTR=ssH: STAT=bbH \*

Where I/O Type is of the following:

READ ERR - Error occurred during read operation

WRITE ERR - Error occurred during write operation

RDAFTWR ERR - The read after write option was selected, and the verify did not agree. The write however, was done successfully.

Note that track and sector values (tt and ss) are expressed in hexadecimal.

The status value (bb) is eight bits of status flags from the disk controller, expressed in hexadecimal. Only the status flags listed below are used for error indicators.

04H (bit 2) - Lost data (data overrun/underrun)

08H (bit 3) - CRC error

10H (bit 4) - Record Not Found (RNF)

20H (bit 5) - Write Fault for Write command

40H (bit 6) - Write Protect Flag

80H (bit 7) - Not Ready Flag

These codes show up in messages like this:

A DRV: ERR CODE = D

READ ERR: TRK=02, SIDE=00, SCTR=05: STAT=10H

This message would tell the user that he has a non-recoverable disk I/O error (ERR CODE = D) on the second track of sector 5 on side 0, and its status, 10H refers to bit 4, Record Not Found.





EXIDY EXCOPY USER'S GUIDE

VERSION 2.0

COPYRIGHT (C) 1980

EXIDY SYSTEMS, INC.

AUGUST 1981

## COPYRIGHT

Copyright (c) 1980 by Exidy Systems, Inc. All rights reserved. No part of this publication may be reproduced, transmitted, transcribed, stored in a retrieval system, or translated into any language, in any form or by any means, electronic, mechanical, magnetic, optical, chemical, manual, or otherwise, without the prior written permission of Exidy Systems, Inc., 1234 Elko Drive, Sunnyvale, California 94086.

Since this manual is tutorial in nature, permission is granted to reproduce or abstract the example procedures and sample programs for the purposes of inclusion within the reader's programs.

## DISCLAIMER

Exidy Systems, Inc. makes no representations or warranties with respect to the contents hereof and specifically disclaims any implied warranties of merchantability or fitness for any particular purpose. Further, Exidy Systems, Inc. reserves the right to revise this publication and to make changes from time to time in the content hereof without obligation of Exidy Systems, Inc. to notify any person of such revision or changes.

## TRADEMARKS

CP/M is a registered trademark of Digital Research.

**EXIDY EXCOPY USER'S GUIDE**

**VERSION 2.0**

**COPYRIGHT (C) 1980**

**EXIDY SYSTEMS, INC.**

**AUGUST 1981**

## COPYRIGHT

Copyright (c) 1980 by Exidy Systems, Inc. All rights reserved. No part of this publication may be reproduced, transmitted, transcribed, stored in a retrieval system, or translated into any language, in any form or by any means, electronic, mechanical, magnetic, optical, chemical, manual, or otherwise, without the prior written permission of Exidy Systems, Inc., 1234 Elko Drive, Sunnyvale, California 94086.

Since this manual is tutorial in nature, permission is granted to reproduce or abstract the example procedures and sample programs for the purposes of inclusion within the reader's programs.

## DISCLAIMER

Exidy Systems, Inc. makes no representations or warranties with respect to the contents hereof and specifically disclaims any implied warranties of merchantability or fitness for any particular purpose. Further, Exidy Systems, Inc. reserves the right to revise this publication and to make changes from time to time in the content hereof without obligation of Exidy Systems, Inc. to notify any person of such revision or changes.

## TRADEMARKS

CP/M is a registered trademark of Digital Research.

## Table Of Contents

### Exidy Systems' Excopy User's Guide: Version 2.0

1.	Introduction.....	262
2.	Use.....	263
3.	Sample Run.....	264
	A. Excopy With Two Multiple Drives.....	264
	B. Excopy With One Drive.....	264
	C. Format Only.....	265
4.	Error Messages.....	266
	A. Can Not Format, Try Again.....	266
	B. Destination Is Write Protected.....	266
	C. Write Error On Track #XX.....	267
	D. Read Back Error On Track #XX.....	267
	E. Additional Messages.....	267
5.	Recovery.....	268



## 1. INTRODUCTION

EXCOPY (TM) is a CP/M (TM) program which formats or copies formatted, soft-sectored diskettes on the Exidy Floppy Disk Subsystem (FDS) and Display Disk System (DDS). The copying operation automatically formats the destination diskette on either a single or a multiple drive configuration. The copy program minimizes the number of read/write cycles performed by determining the amount of RAM available as a copy buffer, using as much of it as possible. Disk formatting without copying may also be performed by the program. The user must not violate any software licensing agreements when copying diskettes.

## 2. USE

The practical user will want to secure back-up copies of all his important files, protecting against any possibility of losing data and enabling the user to read and write to the disk. Also, the user may wish to format only, that is, create on a new disk proper tracks and sectors to read and write to.

EXCOPY is called from CP/M by simply entering "EXCOPY" on the CP/M command line. The program signs on and requests an indication of one of these responses: "C" (or carriage return) for copy, "F" for format only, or "E" (or control-C) for exit back to CP/M.

If copying is requested, the program asks if more than one disk drive is configured and available for the copying operation. The response "Y" or "N" indicates yes or no. If more than one drive is indicated, a message instructs you to place the source diskette in drive A and the destination diskette in drive B. Copying automatically occurs after striking any key.

If only one drive is indicated, a message instructs you to first insert the destination diskette in the A drive for formatting. Hitting any key triggers this process. Then, alternately place source and destination diskettes in the A drive as requested by the console messages.

**WARNING:** Copying and Formatting destroys any previous information on the destination diskette. BE SURE THERE ARE NO IMPORTANT FILES ON THE DESTINATION DISKETTE, AS THEY WILL BE LOST. ALSO, PAY CAREFUL ATTENTION TO THE DRIVE YOU PLACE YOUR SOURCE AND DESTINATION DISKETTE IN. Any mixup will lose all information on your source diskette. Exidy suggests putting write-protect tabs on your source diskette to guard against any such mixup.

After copying, the console asks if more is desired. If your response is "Y" (yes), the cycle is repeated. Otherwise, the program directs the operator to place a system diskette in the A drive, hitting any key to re-boot the system.

Formatting without copying may also be requested. In this case, the program asks the user to specify which drive he wishes to format, "A", "B", or "C". After completion, the program asks if more is desired, and repeats the cycle if "Y" is entered.



3. SAMPLE RUN:

A. EXCOPY With Multiple Drives

Here is a sample of the console I/O when using EXCOPY. For clarification, user input is underlined to differentiate from program output:

A>EXCOPY (return)

Exidy Disk Copy and Format Program  
For 77 Track Single Sided diskettes. Ver 2.0  
Copyright (C) 1981 Exidy Systems, Inc.

or

Exidy Disk Copy and Format Program  
For 77 Track Double Sided diskettes. Ver 2.0  
Copyright (C) 1981 Exidy Systems, Inc.

Format only, Copy, or Exit (F/C/E)?...C

Do you have more than one drive  
configured in this system (Y/N)? Y

Put source diskette in drive A  
and destination diskette in drive B then  
Hit any key when ready. (any key)

(copying commences)

Good Copy.

More (Y/N)? N

Place system diskette in drive A and  
Hit any key when ready to reboot. any key

(CP/M reboots)

B. EXCOPY with One Drive

The following is the console I/O when invoking EXCOPY with only one drive configured on the Sorcerer. An asterisk (\*) indicates the point where the program waits until any key is hit. Track numbers indicated will vary depending on size of RAM. In this example, RAM is 32K. Once again, be sure to begin by placing the DESTINATION diskette in the drive. Should you confuse it with the source diskette, all information will be permanently lost.

A>EXCOPY (return)

Exidy Disk Copy and Format Program  
For 77 Track Single Sided diskettes. Ver 2.0  
Copyright (C) 1981 Exidy Systems, Inc.

or

Exidy Disk Copy and Format Program  
For 77 Track Double Sided diskettes. Ver 2.0  
Copyright (C) 1981 Exidy Systems, Inc.

Format only, Copy, or Exit (F/C/E)?...(return)

Do you have more than one drive  
configured in this system (Y/N)? N

Place destination diskette in drive A  
For initial formatting and  
Hit any key when ready. (any key)

(formatting commences)

	Tracks		Tracks
	Source:* 0-- 6	Destination:*	0-- 6
	Source:* 7--13	Destination:*	7--13
	Source:*14--20	Destination:*	14--20
	Source:*21--27	Destination:*	21--27
and no	Source:*28--34	Destination:*	28--34
	Source:*35--41	Destination:*	35--41
	Source:*42--48	Destination:*	42--48
	Source:*49--55	Destination:*	49--55
	Source:*56--62	Destination:*	56--62
alist ya	Source:*63--69	Destination:*	63--69
to ,end	Source:*70--76	Destination:*	70--76
toform			
no'form			
to stop			
??			

Good Copy.

More (Y/N)? [N]

Place system diskette in drive A and  
Hit any key when ready to reboot. [any key]

(cold boots system diskette)

### C. Format Only

The console I/O for a Format Only operation would  
appear as follows:

A>EXCOPY (return)

Exidy Disk Copy and Format Program  
For 77 Track Single Sided diskettes. Ver 2.0  
Copyright (C) 1981 Exidy Systems, Inc.

or

Exidy Disk Copy and Format Program  
For 77 Track Double Sided diskettes. Ver 2.0  
Copyright (C) 1981 Exidy Systems, Inc.

Format only, Copy, or Exit (F/C/E)?...F  
Select drive (A,B, or C)... B

Place diskette in drive B for formatting then  
Hit any key when ready. any key

(formatting commences)

More (Y/N)? N

(etc.)

#### 4. ERROR MESSAGES

Several conditions may display error messages on the console, as follows:

##### A. Cannot format, try again

This message appears when the disk controller fails either to write a track with the formatting data, or after writing, the controller cannot read back each sector on the track in question. An improper destination diskette (such as a hard-sectored diskette) or a worn or damaged one may cause this. Also, malfunctioning disk drive hardware which prevents formatting may return this message. Try fresh media and double-check the hardware. The program automatically restarts after each error to allow another attempt.

##### B. Destination is write protected.

This message is given if the destination diskette has a write protect tab covering its write protect notch. Either remove the tab or use an unprotected diskette.

**C. Write error on track # xx**

This message is returned during formatting if the write operation cannot be performed. The track number (xx) is specified.

**D. Read back error on track # xx**

This message is displayed if a track can be written to but cannot be read back after repeatedly attempting to do so. Again, the track number is specified as (xx).

**E. Additional Message**

I can't find your boot address!!!  
Please enter it...[hhhh]

This occurs if a non-Exidy boot-strap controller prom is used and the copy program can't determine where the cold bootprogram is addressed. In this event, simply enter the hexadecimal address of your boot-strap prom. This should not occur if Exidy hardware and software is used.

## 5. Recovery

If the copy program has errors while reading the source, writing the destination, or verifying the destination diskette, the program repeatedly attempts the operation until successful. If, after many attempts, the operation still has errors, a message is displayed and the error retry continues indefinitely.

These messages are:

Recovering from read errors, track # xx

Recovering from write errors, track # xx

If it appears that the copy program cannot recover from an error, reset the computer to end processing and check ground and other connections between computer and disk drive. Also check the diskette for wear.

