

INSTRUCTION MANUAL
FOR
MODEL NRD-525



JRC *Japan Radio Co., Ltd.*

GENERAL COVERAGE RECEIVER

Thank you for purchasing the NRD-525 General Coverage Receiver.

The NRD-525 is a high quality receiver with the latest digital circuits and semiconductors developed from many years of JRC's experiences and achievements in the field of radio communication. Please read through this manual before use.

The product you have purchased is produced under strict quality control. Should you find any trouble or damage, please contact the nearest JRC branch or dealer as soon as possible.

ACCESSORIES

The NRD-525 has the following accessories. Check your accessories against the following list:

- Instruction manual 1
- M type coaxial plug 1
- Pin plug 5
- Phone plug 1
- Record plug 1
- 1-A fuse 1
- DC power cord (6ZCJD00127) 1
- AC power cord 1

PRECAUTIONS

1. *Even when the power for the Receiver is switched off, a small amount of current flows for backup of the clock. If you are going to leave the Receiver unused for a long time, remove the AC or DC power cable on the rear panel. (Then, the clock will not be backed up.) Take special care when a battery is used as the power source.*
2. *Read the markings on the corrugated cardboard package and confirm the voltage of the AC power source which you can use.*
3. *If you are going to use DC mains as the power source for the Receiver, use the correct DC power cable. If you are going to use any other cable, be sure to fit an in-line 3A fuse.*
4. *Never connect an AC power source to the timer output terminal. It is very dangerous!*

■ CONTENTS

- 1. FEATURES 4
- 2. RATINGS 5
- 3. BEFORE USE 6
 - 3.1 Mounting Place 6
 - 3.2 Mounting 6
- 4. SWITCHES AND CONTROLS ON PANELS 7
 - 4.1 Front Panel 7
 - 4.2 Rear Panel 12
- 5. OPERATION 14
 - 5.1 Reception 14
 - 5.2 Use of Preset Memory 16
 - 5.3 Scan and Sweep 16
 - 5.4 Setting of Clock and Timer 17
 - 5.5 Change of Operation by User's Definition 18
- 6. CIRCUIT DESCRIPTION 20
 - 6.1 Outline 20
 - 6.2 Unit 20
- 7. ADJUSTMENT AND MAINTENANCE 21
 - 7.1 Adjustment 21
 - 7.2 Maintenance 21
- 8. TROUBLESHOOTING 22
 - 8.1 Simple Trouble 22
 - 8.2 Complicated Trouble 22
- 9. OPTION 24
 - 9.1 Option 24
 - 9.2 Mounting of Option 24
- 10. BLOCK DIAGRAM 26
- 11. CIRCUIT DIAGRAM 27

□ Nomenclature

(While reading the text, you may refer to this page for identification of parts from time to time.)

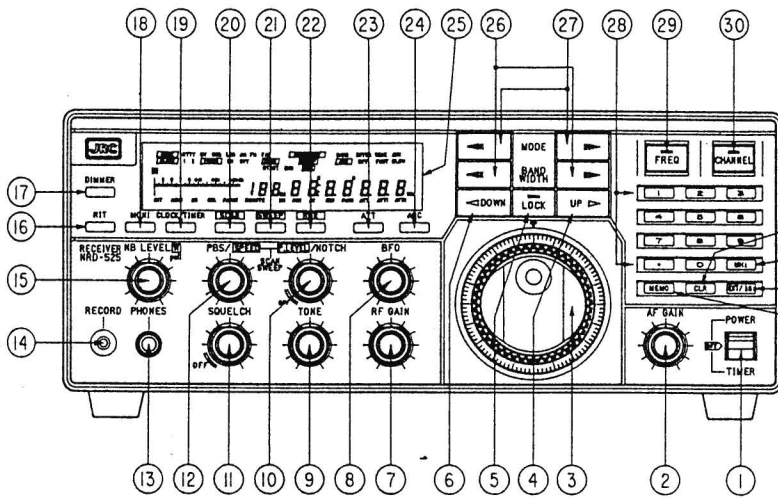

Front panel

- (1) POWER/TIMER ON-OFF switch
- (2) AF GAIN control
- (3) TUNING control (This control also works as RIT control when characters "RIT" are on.)
- (4) UP switch
- (5) LOCK switch
- (6) DOWN switch
- (7) RF GAIN control
- (8) BFO control
- (9) TONE control
- (10) NOTCH control (It also works as P LEVEL (pause level) control during scan or sweep reception.)
- (11) SQUELCH control
- (12) PBS (pass band shift) (It also works as the SPEED control during scan or sweep reception.)
- (13) PHONES jack
- (14) RECORD jack
- (15) NB LEVEL (noise blanker level) control
- (16) RIT switch
- (17) DIMMER switch
- (18) MONI (monitor) switch
- (19) CLOCK/TIMER switch
- (20) SCAN switch
- (21) SWEEP switch
- (22) RUN switch
- (23) ATT (attenuator) switch
- (24) AGC control
- (25) Vacuum Fluorescent Display (VFD)
- (26) BANDWIDTH switch
- (27) MODE switch
- (28) Numerical keys
- (29) FREQ (frequency) switch
- (30) CHANNEL switch
- (31) CLR (clear) switch
- (32) MHz switch
- (33) ENT/kHz switch
- (34) MEMO (memory) switch

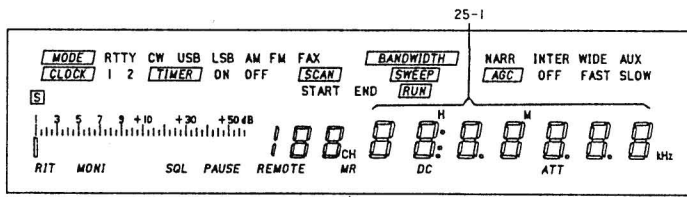

(25) Vacuum Fluorescent Display (VFD)

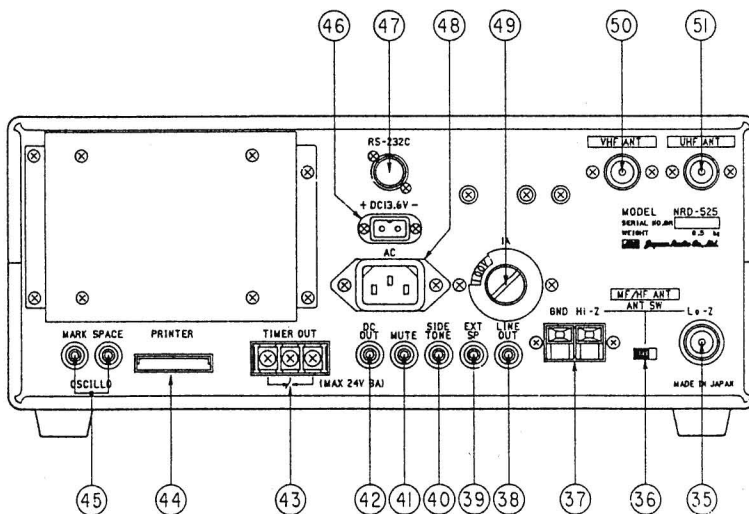

Rear panel

- (35) MF/HF ANT Lo.Z (low impedance) connector
- (36) ANT switch
- (37) MF/HF ANT Hi-Z (high impedance) terminal, GND(grounding) terminal
- (38) LINE OUT (line output) jack
- (39) EXT SP (external speaker) jack
- (40) SIDE TONE jack
- (41) MUTE jack
- (42) DC OUT (DC output) jack
- (43) TIMER OUT (timer output) terminal
- (44) PRINTER connector
- (45) Jack for RTTY indicator
- (46) DC power connector
- (47) Connector for RS-232C
- (48) AC power connector
- (49) AC fuse, voltage selector
- (50) VHF ANT connector
- (51) UHF ANT connector

In the above figure, (47), (50), and (51) are positioned supposing that the options are mounted.

1. FEATURES

1) Wide receiving frequency range

The standard receiving frequency range is from 90 kHz to 34MHz. If the optional VHF/UHF Converter is installed, the receiving frequency ranges of 30-60, 114-174, and 423-456 MHz can be used. This extends the range of application of the receiver.

2) Wide dynamic range

Use of a grounded gate push-pull FET mixer and electronic tuning system secures a wide dynamic range with the emphasis put on multiple-signal characteristics.

3) Electronic tuning system

The automatic tuning method incorporated in the widely accepted JRC's professional purpose receivers is employed. (The double tuned circuit with capacitor diodes, controlled by a microcomputer.) This gives improved front end selectivity, and better matching to the antenna.

4) Large memory capable of storing 200 channels

The CMOS-RAM backed up by a lithium battery can store a maximum of 200 channels, each channel containing data on the frequency, mode, bandwidth, AGC, and ATT.

5) Scan sweep reception

If a start channel (frequency for sweep) and end channel (frequency for sweep) are set, scan reception (sweep reception) can be carried out. Sweep speed and stop level are adjustable.

6) Frequency stability to high quality receiver standard

The ± 3 PPM standard frequency oscillator assures high frequency stability in each of the MF, HF, VHF, and UHF bands.

7) Teletype reception

Use of the optional RTTY demodulator allows teletype reception. Any Centronics compatible printer can be used.

8) Clock/timer

The two built-in clocks can be used as Local time and UTC (GMT). They can be also used as a timer to control a tape recorder, etc.

9) Direct access tuning

In addition to the flywheel tuning control, the frequency can quickly be selected by numerical keys.

10) Compatibility with personal computer

The optional RS-232C interface allows control from a personal computer. For instance, the frequency, mode, bandwidth, time, and other data may be entered into the program. Thus, the Receiver works as a programmable automatic receiver.

11) Adoption of latest manufacturing techniques

The NRD-525 employs as many surface mounted parts as possible, including resistors, capacitors, transistors, and diodes. Thus, automated production, consistent quality, and cost cut-down have been achieved. Employment of plug-in type PCB modules has improved reliability and serviceability.

12) All-in-one construction

All the optional units such as the RS-232C interface, RTTY demodulator, and VHF/UHF converter can be housed in the receiver cabinet.

13) Built-in loudspeaker

No externally mounted units are necessary for reception because the Receiver has a built-in loudspeaker.

14) Dual power supply system

Either 100/120/220/240 V AC or 13.8 V DC can be used as the power source. Therefore, the Receiver can be used both indoors and outdoors.

2. RATINGS

- 1) **Receiving frequency range** 0.09-34MHz
34-60MHz(See NOTE 1.)
114-174MHz(See NOTE 1.)
423-456MHz(See NOTE 1.)
- 2) **Receiving mode** RTTY, CW, SSB(USB, LSB)
AM, FM, FAX
- 3) **Memory channel** 200 channels
- 4) **Receiving system** Double superheterodyne
1st IF 70.45399-70.453MHz
2nd IF 455 kHz

5) Sensitivity

MODE FREQUENCY	RTTY, FAX CW, SSB	AM	FM
0.09-1.6MHz	5.0 μ V	15 μ V	-
1.6-34MHz	0.5 μ V	2 μ V	0.7 μ V
34-60MHz	1.0 μ V	3 μ V	1.5 μ V(See NOTE 1.)
114-174MHz	1.0 μ V	3 μ V	1.5 μ V(See NOTE 1.)
425-445MHz	1.0 μ V	3 μ V	1.5 μ V(See NOTE 1.)

S/N=10dB, AF output=100mW, bandwidth=INTER
Modulation=400Hz, 30%(during AM measurement)
NQL=20dB(during FM measurement)
Antenna impedance=50 Ω

6) Selectivity

Bandwidth	6dB	60dB
AUX	12kHz or more	-(See NOTE 2.)
WIDE	4KHz or more	10kHz or less
INTER	2kHz or more	6kHz or less
NARR	1kHz or more	3kHz or less (See NOTE 3.)
FM	12kHz or more	-

- 7) **Image frequency rejection ratio** 70 dB or more
- 8) **Intermediate frequency rejection ratio** 70 dB or more
- 9) **Frequency stability** ± 3 PPM
- 10) **Dynamic range** 100 dB or more (with 500Hz IF selectivity)
- 11) **PBS variation range** ± 1 kHz or more
- 12) **Notch attenuation** -30 dB or more
- 13) **BFO variation range** 455 kHz ± 2 kHz or more

- 14) **RIT variation range** ± 5 kHz, maximum
- 15) **Nominal Antenna impedance** 0.09-34MHz 50 Ω (Lo-Z terminal)
600 Ω (Hi-Z terminal)
34-60MHz 50 Ω (VHF terminal)
(See NOTE 1.)
114-174MHz 50 Ω (VHF terminal)
(See NOTE 1.)
423-456MHz 50 Ω (UHF terminal)
(See NOTE 1.)

- 16) **AF output** Speaker output : 0.5 W or more (at 4 Ω load and 10% distortion)
Line output : 1 mW or more (at 600 Ω load and 10% distortion)
Recording output : 1m W or more

- 17) **Antenna input attenuation** Approx. 20 dB for HF
Approx. 10 dB for VHF/UHF (See NOTE 1.)

- 18) **AGC characteristic** Change of output is 10 dB or less when the antenna input changes by 3 μ V to 100 mV.

- 19) **Power source** 100/120/220/240 V AC $\pm 10\%$
Max. 35 VA
12-16V DC (standard 13.8 V)
Max. 25 W

- 20) **Auxiliary circuits** Noise blanker, S meter, side tone input, mute input, transmission monitor, squelch, dimmer, tone control, clock, timer, IF notch filter, pass band shift

- 21) **Dimensions** 330(W) \times 130(H) \times 280(D)(excluding projected parts)

- 22) **Weight** Approx. 8.5 kg

NOTE 1: With the optional V.UHF converter CMK-165.

NOTE 2: If the optional If filter (e. g. CFL-231) is mounted, the bandwidth for 6dB is 0.3 kHz.

NOTE 3: With the optional If filter CFL-233.

3. BEFORE USE

3.1 Mounting Place

For installation, avoid a place where the Receiver can be exposed to direct sun, hot air from an air conditioner, dust, vibration, or humidity so that you may use the Receiver for a long time with its performance fully maintained. Select a well ventilated place.

Ensure a sufficient clearance behind the Receiver so that it may not be closely put to the wall.

3.2 Mounting

To operate the set, such preparations must be made as erection of the antenna, grounding, and connection to the power source. Connect the components as shown in Fig. 3-1.

1) Erection of antenna

The antenna should preferably be mounted outdoors to have the Receiver operate at it's best performance.

Use an HF antenna with a low impedance (e. g. the inverted L type preferably with the vertical portion height of 10 metre or more and the horizontal portion length of 10 to 20 metres, doublet type, or Yagi type. Connect one end of the coaxial cable (50Ω or 75Ω) to the antenna, and the other end to the MF/HF ANT Lo-Z connector on the rear panel. In doing so, do not forget to put the ANT switch to the Lo-Z position.

If a high impedance antenna such as 4-to 6-m long vinyl coated wire is to be used, connect it to the MF HF Hi-Z terminal on the rear panel. In this case, the ANT switch must be put to the Hi-Z position.

2) Grounding

Reception is possible without grounding. However, to prevent electric shock and damage to devices, connect a thick

copper grounding wire to the GND terminal on the rear panel.

3) Connection to power source

If you are going to use an AC power source, connect the correct AC power cable to the AC power connector on the rear panel. To operate the receiver from a DC, connect the DC power cable to the DC power connector on the rear panel.

The AC power source voltages, which you can use are marked on the package. Ascertain that these values are identical to the voltages marked on the voltage selector on the rear panel. If any other voltage is to be used, select a voltage nearest to that you are going to use, from 100V, 120V, 220V, and 240V, and set the voltage selector at that value, provided that the difference between these voltages should be within $\pm 10\%$ of the voltage marked on the voltage selector.

Example: 115V → 120V 230V → 240V (See Fig. 3-2)

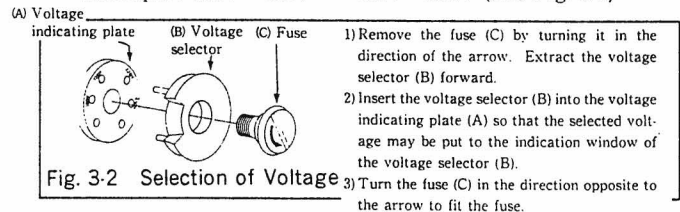

Fig. 3-2 Selection of Voltage

4) Connection of speaker

The Receiver has a built-in speaker, but an external speaker can be connected to it if necessary. Use of the JRC NVA-88 (option) is recommended.

5) Connection of headphone

We recommend use of the JRC communications headphones ST-3 (option).

If you are going to use headphones of any other type, select one with impedance of 4 to 16Ω. A stereo record player headphone can be used as it is.

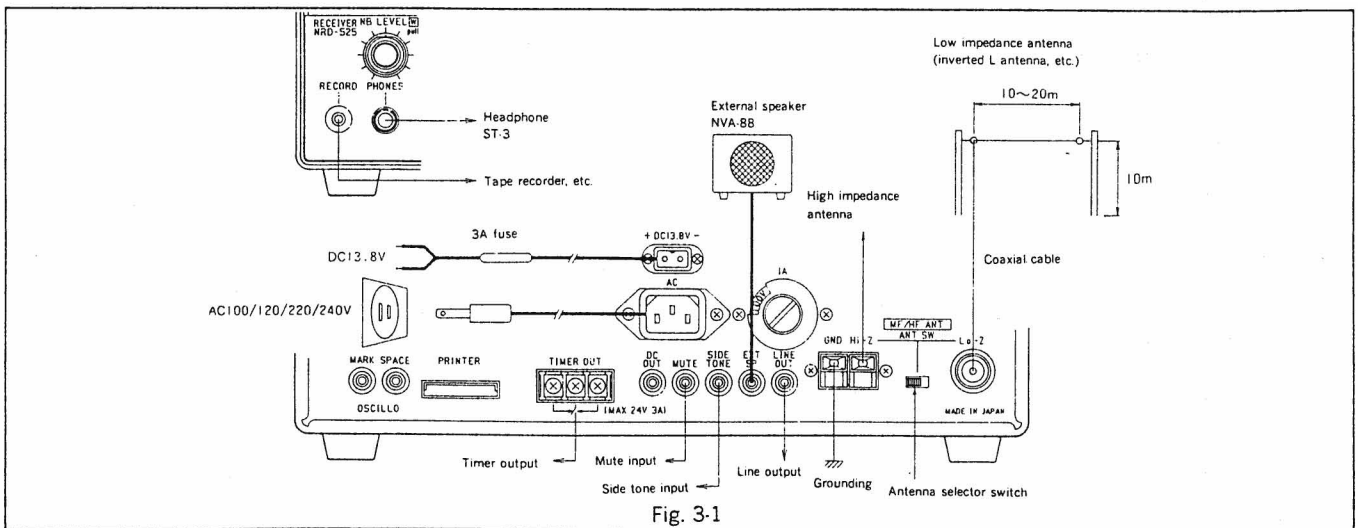

4. SWITCHES AND CONTROLS ON PANELS

4.1 Front Panel

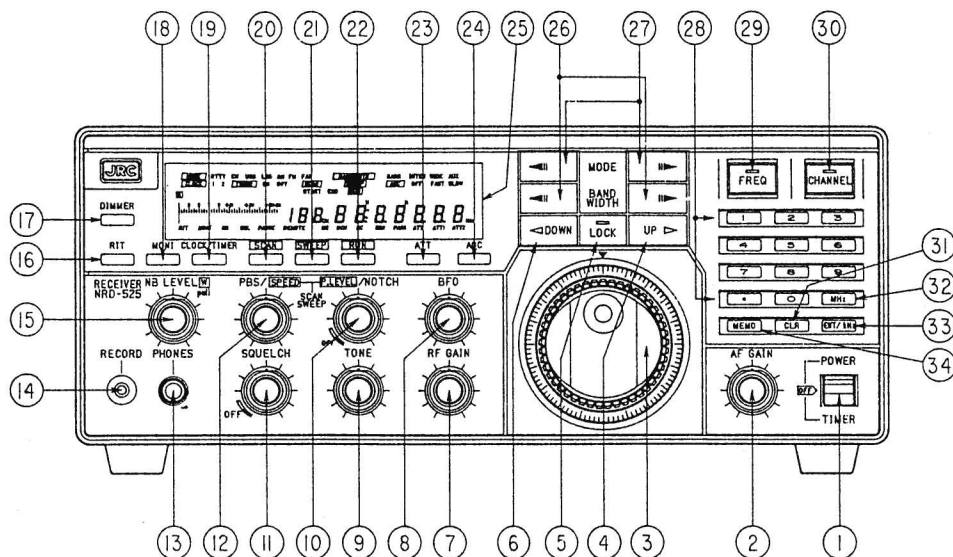

(1) POWER/TIMER ON-OFF switch

If this switch is put to the POWER position, the power is switched on, and the NRD-525 begins to operate. If it is put to the TIMER position, the timer functions. If it is put to the OFF position, the Receiver does not operate. Please note that a small amount of current for internal clock circuit flows while the switch is in OFF position.

(2) AF GAIN control

Controls the AF (audio) output level. Turning it clockwise increases the volume of sound.

(3) TUNING control

Changes the receiving frequency in 10 Hz steps. Turning it clockwise increases the frequency. If the RIT switch is turned on, this control works as the RIT control.

(4) UP switch

If the FREQ switch (29) is turned on, you can increase the frequency in 1 kHz steps (5 kHz steps in the FM mode) with this switch. If the CHANNEL switch (30) is turned on, you can increase the channel number. Use this switch together with the DOWN switch (6). Because this switch is of auto repeat type, the frequency or channel number increases continuously while it is pressed. The DOWN switch also works in the similar manner.

(5) LOCK switch

If this switch is turned on, the (3), (4), (6), (16), (18) through (24), and (26) through (34) controls and switches are electrically disabled. This switch may be used if you want to avoid erroneous operation during reception.

If the switch is turned on, the red LED at the center of the switch is lit to indicate the locking.

(7) RF GAIN control

This control is used to adjust the gain of the 1st and 2nd intermediate frequency amplifiers. If it is turned fully clockwise, the gain is maximum. As you turn it counterclockwise after turning it fully clockwise, the gain decreases gradually. At the same time the S meter begins to deflect. When the S meter indicates S9, the total gain of the 1st and 2nd IF amplifier is attenuated by about 40 dB. If the control is turned fully counterclockwise, the gain is attenuated further, and neither receiving signal nor noise can be heard. Then, the S meter will not move because it has reached the limit.

If you are receiving a relatively strong signal, set this control at a value equivalent to or a little smaller than the reading of the S meter. Then, the noise between signals will reduce and you can hear easily. Ordinarily, this control is turned fully clockwise.

(8) BFO control

This control works only in the CW mode. It changes the tone of the AF (audio) output. Rotation of the control by one division of the scale can change the tone by about 500 Hz. The tone

changes in the range of about +2.5 kHz when the control is turned from the neutral (central) position to the maximum.

If this control is put to the neutral position when the Receiver is tuned to the carrier wave of the received signal, the beat of the AF (audio) output signal becomes zero, and beat note cannot be heard. Ordinarily, the BFO control is moved clockwise or counterclockwise from the neutral position. If the control is moved by 1.5 division from the neutral position, the beat note of about 800 Hz can be heard.

If CW is received with BFO control put to the neutral position, and the AF (audio) output is set at the zero beat with the TUNING control (3), the frequency of CW currently received can be easily known from by reading the indicator of the receiving frequency at that time.

(9) TONE control

This control is used to change the high frequency response of the AF (audio) output to adjust the sound quality. You can use this control to select any desired sound quality. Turning it clockwise increases the high frequency response. Ordinarily, it is put to the neutral position.

(10) NOTCH control/P LEVEL (pause level) control

If the received signal sustains heterodyne interference due to a continuous carrier or signal such as CW, this control may be turned clockwise from the OFF position to the ON position so as to minimize the heterodyne. If the control is put to the central position in the LSB or USB mode, the beat interference equivalent to about 1.5 kHz (AF output) can be eliminated.

This control is used as P LEVEL (pause level) control for automatic pausing when scan or sweep is being executed with the RUN switch (22) depressed. As the control is turned counterclockwise, a stronger input signal is required for pausing. When pausing is accomplished, the red characters "PAUSE" on the vacuum fluorescent display (25) are illuminated for warning.

CAUTIONS

1. The notch facility does not work when scan or sweep is being executed.
2. IF the notch control is turned on, the received signal may be distorted. So, it should be turned off unless necessary.

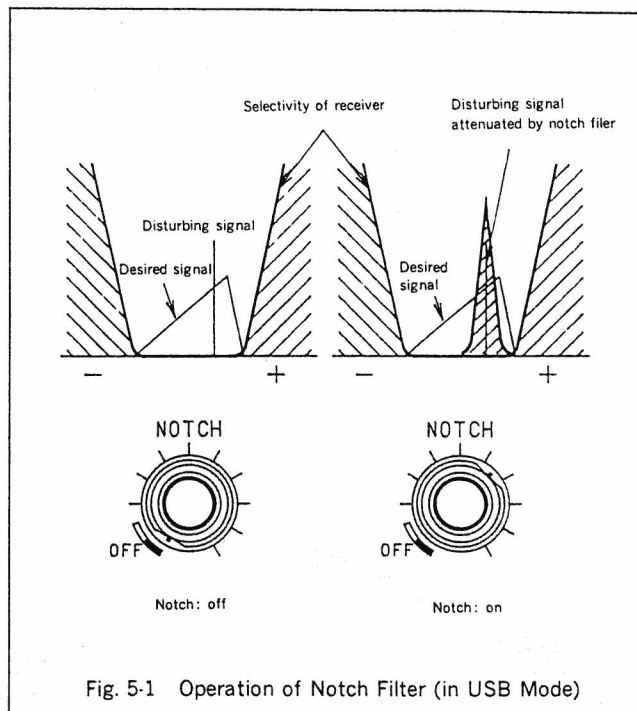

Fig. 5-1 Operation of Notch Filter (in USB Mode)

(11) SQUELCH control

If the SQUELCH control is turned clockwise from the OFF position, the squelch is turned on. This control works in any mode.

If the squelch is closed (if there is no AF output), red letters "SQL" on the vacuum fluorescent display (25) are illuminated for warning. As the control is turned clockwise, higher input level is required to open the squelch. If the squelch is opened, the "SQL" indication goes out.

The SQUELCH control will not work when the AGC is turned off.

(12) PBS (pass band shift) control/SPEED control

This control varies the apparent intermediate frequency for the IF filter by about ± 1 kHz without changing the receiving frequency. This function allows elimination of the adjacent signal by means of the edge of the filter when the side band of the adjacent signal is overlapped on the receiving frequency.

If this control is turned counterclockwise from the neutral position in the USB mode, interference from higher components of the voice signal can be eliminated. At this time, the high band portion of the received signal is also cut (high cut). In the LSB mode, the above relationships are reversed.

This control works as the SPEED control during scan or sweep reception. The speed is maximum when the control is turned fully clockwise. The speed becomes lower as the control is turned counterclockwise.

CAUTION

Signal quality is adversely affected if the Receiver is operated with the PBS (pass band shift) control turned fully clockwise or counterclockwise. Put the control to the neutral position unless necessary.

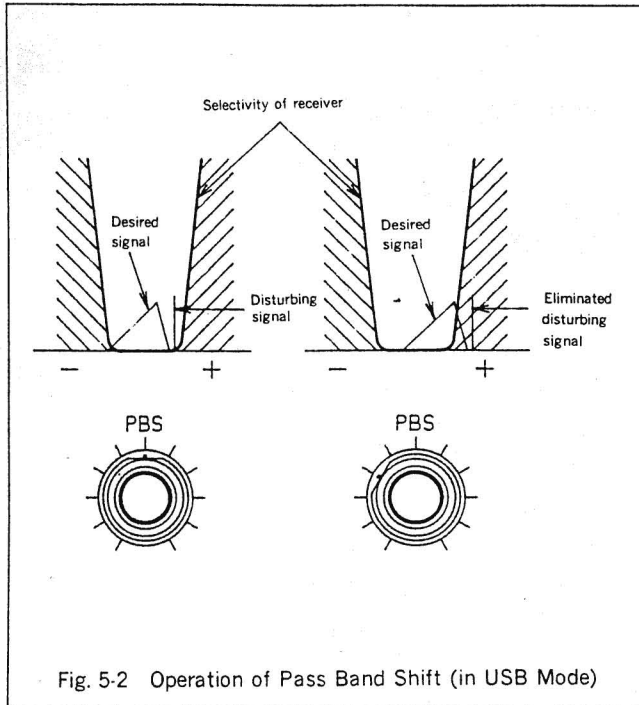

Fig. 5-2 Operation of Pass Band Shift (in USB Mode)

(13) PHONES jack

Output jack for the headphone. Use headphones with an impedance of 4 to 16 Ω . Stereophonic headphones can be used without modification. When using headphones, the internal and external speaker are automatically disconnected.

(14) RECORD jack

Used to record what is received on a tape recorder. The output level is independent of the position of the AF GAIN control. The output impedance is 600 Ω .

(15) NB LEVEL (noise blanker level) control

Strong pulse noise similar to the ignition noise from an automobile can be eliminated if this control is turned clockwise. As this control is turned clockwise, the sensitivity of the noise blanker becomes higher, and noise with fairly low level can be eliminated. Take care not to turn it excessively lest the received signal should be distorted. If this control is pulled forward, wide pulse noise such as "woodpecker" noise can be eliminated. In this case, the sensitivity can be adjusted by turning the control.

Unless necessary, leave this control turned fully counterclockwise.

(16) RIT switch (receiver increment tuning)

This switch works only when FREQ switch (29) or the CHANNEL switch (30) is pressed. If this switch is turned on, the characters "RIT" and the amount of change in receiving frequency is displayed on the vacuum fluorescent display (25). The TUNING control (3) also works as the RIT control. It can change the frequency by maximum ± 5 kHz.

When using RIT, the UP switch (4), DOWN switch (6), CLOCK/TIMER switch (19), SCAN switch (20), SWEEP switch (21), FREQ switch (21), CHANNEL switch (30), and numerical keys become inoperative.

(17) DIMMER switch

This switch is used to change the brightness of the vacuum fluorescent display and LEDs. Each time the switch is pressed, the brightness changes in four steps from total extinction to maximum brightness.

(18) MONI (monitor) switch

In case the Receiver is used in combination with a transmitter, this switch allows monitoring of transmission signal. If the switch is turned on, the characters "MONI" on the vacuum fluorescent display (25) are illuminated in red.

(19) CLOCK/TIMER switch

This switch is used to select either CLOCK 1, CLOCK 2, TIMER ON, or TIMER OFF. Each time this switch is pressed, CLOCK 1, CLOCK 2, TIMER ON, or TIMER OFF is selected in that order. If it is pressed further, CLOCK 1 is selected again.

- CLOCK 1 : Time such as local time is set.
- CLOCK 2 : Time such as UTC (Universal Coordinated Time) is set.
- TIMER ON : Time at which power for NRD-525 is switched on by the timer.
- Timer OFF : Time at which power for NRD-525 is switched off by the timer.

If CLOCK 1, CLOCK 2, TIMER ON, or TIMER OFF is selected, the time is indicated on the vacuum fluorescent display (25). At this time, the time can be set if desired.

To clear the setting of the CLOCK/TIMER switch, press the SCAN switch (20), SWEEP switch (21), FREQ switch (29), or CHANNEL switch (30) according to what you want to do.

CAUTION

All times are shown using the 24 hour clock.

(20) SCAN switch

This switch is used to select SCAN START or SCAN END. Each time the switch is pressed, SCAN START and SCAN END are selected in turn.

- SCAN START: Channel number at which scan starts by means of the SCAN function.
- SCAN END: Channel number at which scan ends by means of the SCAN function.

If SCAN START or SCAN END is selected, the channel and the frequency, mode, bandwidth, status of AGC, on-off status of ATT are indicated on the vacuum fluorescent display (25). At this time, reception can be done with use of the information stored in the selected channel number. Also, the channel number can be set. In this status, scan is not executed. To execute scan, the RUN switch (22) must be turned on. At this time, it does not make any change whether SCAN START or SCAN END have been selected.

To clear the setting of the SCAN switch, press the CLOCK/TIMER switch (19), SWEEP switch (21), FREQ switch (29), or CHANNEL switch (30) according to your requirement.

(21) SWEEP switch

This switch is used to select SWEEP START or SWEEP END. Each time the switch is pressed, SWEEP START and SWEEP END are selected in turn.

- SWEEP START: Frequency at which sweep starts by means of the SWEEP function.
- SWEEP END: Frequency at which sweep ends by means of the SWEEP function.

If SWEEP START or SWEEP END is selected, the frequency is indicated on the vacuum fluorescent display (25). At this time, reception can be done on the selected frequency. Also, the frequency can be changed. In this status, sweep is not executed. To execute sweep, the RUN switch (22) must be turned on. At this time, it does not matter whether SWEEP START or SWEEP END have been selected.

To clear the setting of the sweep switch, press the CLOCK/TIMER switch (19), SCAN switch (20), FREQ switch (29), or CHANNEL switch (30) according to your requirement.

(22) RUN switch

This switch is used to execute scan or sweep.

If this switch is turned on when the SCAN switch (20) is pressed and SCAN START or SCAN END is indicated, scan begins with the start channel number.

If this switch is turned on when the SWEEP switch (21) is turned on and SWEEP START or SWEEP END is indicated,

sweep begins with the start frequency. If the RUN switch is turned on, the characters "RUN" on the vacuum fluorescent display (25) are illuminated. If this switch is depressed again, SCAN or SWEEP stops.

(23) ATT (attenuator) switch

This switch is used to turn on and off the attenuator (approx. 20 dB in HF band) in the antenna input circuit.

(24) AGC switch

The AGC switch is used to turn off AGC, or to select time constant (slow or fast) of AGC. Each time the switch is pressed, the AGC indication on the vacuum fluorescent display (25) changes in the order shown below. Select SLOW, FAST, or OFF according to your requirement.



Ordinarily, they are selected in the following manner.

- AGC SLOW: If AGC SLOW is selected when relatively strong signal is being received, noise between signals is suppressed. Thus, you can hear the signal easily. Generally, this position is used in the SSB mode.
- AGC FAST: If AGC FAST is selected when you are receiving strong and weak signals in turn, AGC quickly responds to the weak signal sent after the strong signal. Thus, you can hear the signal easily because the start of each signal is not cut off. Ordinarily, this position is used in the CW or AM mode.
- AGC OFF: In this position, the S meter does not read at all. This position is used to receive relatively weak signal. Because the voice signal is distorted if strong signal is received, turn the RF GAIN control (7) counterclockwise to eliminate distortion.

In the FM mode, this switch becomes inoperative.

(25) Vacuum fluorescent display

A large vacuum fluorescent display is used to indicate the items illustrated below.

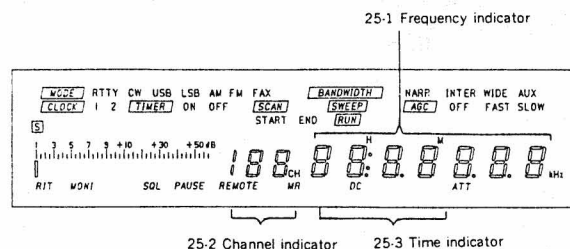

25-1 frequency indicator : Indicates receiving frequency in 7 digits. If RIT is on, the amount of change of RIT is shown in three digits. At this time, time is not shown.

25-2 channel indicator : Indicates the channel number in 3 digits.

25-3 time indicator : Time for CLOCK 1, CLOCK 2 , TIMER ON, and TIMER OFF is shown in 4 digits. At this time, the frequency is not shown.

MODE : Indicates mode. Either RTTY, CW, USB, LSB, AM, FM, or FAX is selected and illuminated.

BANDWIDTH : Indicates the bandwidth. Either NARR, INTER, WIDE, or AUX is selected and lit.

CLOCK 1 : Lit to indicate time for CLOCK 1.

CLOCK 2 : Lit to indicate time for CLOCK 2.

TIMER ON : Lit to indicate time for TIMER ON.

TIMER OFF : Lit to indicate time for TIMER OFF.

SCAN START : Lit to indicate scan start channel.

SCAN END : Lit to indicate scan end channel.

SWEEP START : Lit to indicate sweep start frequency.

SWEEP END : Lit to indicate sweep end frequency.

RUN : Lit in yellow during scan or sweep is being executed.

AGC : Indicates the status of AGC. Either OFF, FAST, or SLOW is selected and lit.

S (S meter) : Indicates the intensity of received signal in terms of 1 through 9, and 9+10 dB through 9+50 dB.

RIT : Lit in red during execution of RIT.

MONI (monitor) : Lit in red during operation of transmitting monitor.

SQL (squelch) : Lit in red when squelch is closed.

PAUSE : Lit in yellow when scan or sweep is paused by manipulation of the P LEVEL (pause level) control (10).

REMOTE : Lit in yellow when NRD-525 is remotely controlled by the optional RS-232C unit.

MR (memory read) : Lit in red when memory channel is read out.



DC : Lit in red when NRD-525 is operated from a DC power source.

ATT : Lit in red when attenuator is turned on.

PASS : Lit when the input RF filter is bypassed.

(26) BANDWIDTH switch

This switch is used to select the bandwidth (for the IF filter).

Press the  or  switch to move the indication of the bandwidth on the vacuum fluorescent display (25) to the right or left to select the desired bandwidth. In the FM mode, you cannot select the bandwidth with this switch because the bandwidth is fixed at 12 kHz.

Ordinarily, the bandwidth is selected in the following manner according to the mode.

- NARR (0.5 kHz) : For reception in RTTY, or CW mode (with the optional filter CFL-232 mounted)

- INTER (3 kHz) : For reception in the USB, LSB or FAX mode.



- WIDE (6 kHz) : For reception of AM

- AUX (12 kHz) : For reception of AM (without optional filter)

If the optional filter is not mounted for the narrow band, NARR cannot be selected. Also, an optional filter can be mounted for AUX. In this case, the bandwidth equivalent to that of the optional filter can be used.

(27) MODE switch

Used to select the mode (type of emission).

To select the desired mode, press  or  switch and move the mode indication on the vacuum fluorescent display (25) to the right or left.

(28) Numerical keys

These are used to set the receiving frequency, channel, and time. If they are manipulated improperly, beeping sound is given in the speaker as a warning.

(29) FREQ (frequency) switch

If this switch is turned on, the LED at the center of the switch is illuminated in green. Then, you can set the frequency with numerical keys (28).

(30) CHANNEL switch

If this switch is turned on, the LED at the center of the switch is illuminated in green. Then, you can set the channel with numerical keys (28).

(31) CLR (clear) key

If you have made a mistake during entry of the frequency, channel, or time data with ten keys (28), press this switch to clear the data just entered. Then data set previously will be recovered.

(32) MHz switch

Used to set the frequency in MHz with numerical keys (28). Pressing this switch completes the data entry.

(33) ENT/kHz switch

In case a frequency setting in kHz, channel selection or time setting, press this switch after manipulation of the Numerical keys (28). Pressing this switch completes the data entry.

(34) MEMO (memory) switch

Used to store data in the memory channel, or to make user definition.

4.2 Rear Panel

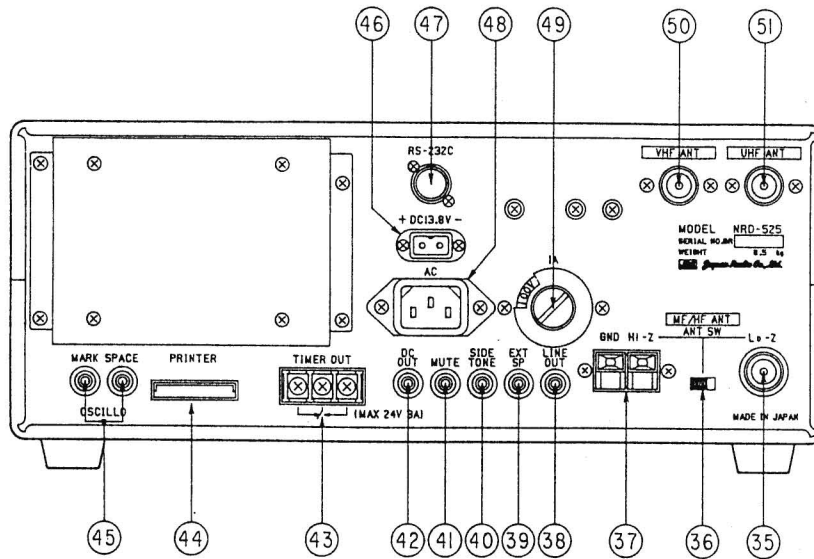

(35) MF/HF ANT Lo-Z (low impedance) connector

This MF/HF antenna connector is used to connect a low impedance (50 Ω) antenna. To use the NRD-525 to its full performance, use an antenna with as good a performance as possible.

(36) ANT SW (switch)

Used for selection between low and high impedance of the MF/HF antenna.

(37) MF/HF ANT Hi-Z (high impedance) terminal

This MF/HF antenna terminal is used to connect a high impedance antenna.

(38) LINE OUT (line output) jack

This output has just the same function as that of the RECORD jack (14) on the front panel.

(39) EXT SP (external speaker) jack

Used to connect an external speaker if necessary.

(40) SIDE TONE jack

Side tone input jack used when a transmitter is used in combination with the NRD-525.

(41) MUTE jack

Input jack for control of mute of NRD-525 when a transmitter is used in combination. If this is grounded during transmission shown in the following figure, the NRD-525 is muted (AF output is cut off).

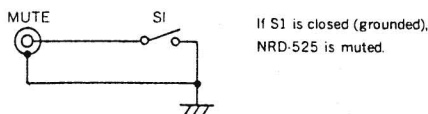

(42) DC OUT (output) jack

The 10.8 V DC output jack. The output current capacity is about 30 mA maximum.

(43) TIMER OUT (output) terminal

The relay contacts are output to allow the timer to control an external device.

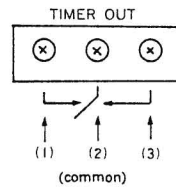

If the timer is on (power for NRD-525 is on), the contacts (2) and (3) are closed (connected).
 If the timer is off (power for NRD-525 is off), the contacts (1) and (2) are closed.
 The contact capacity is maximum 24 V 3 A.

Never connect an AC power source to this terminal.

(44) PRINTER connector

If an output is to be fed to the printer when the optional RTTY demodulator CMH-530 is used for reception of RTTY, the printer must be connected to this connector. The printer used should be compatible with Centronics (e.g. one used for a personal computer).

(45) RTTY INDICATOR output

Output for mark and space signal indicator in case the optional RTTY demodulator CMH-530 is used for reception of RTTY. It can be connected the X and Y axes inputs of an oscilloscope to display a cross pattern for precise tuning.

(46) DC power connector

Used when the NRD-525 is operated from a DC power source

Connect the correct DC power cable to this connector. If any other cable is to be used, be sure to fit an in line fuse of 3A rating.

(47) RS-232C connector

This connector is used when the optional RS-232C interface unit CMH-532 connected to a personal computer is used to remotely control the NRD-525.

This connector is attached to the CMH-532. It is not provided as a standard accessory.

(48) AC POWER connector

Used when the NRD-525 is operated from an AC power source. Connect the correct AC power cable to this connector.

(49) AC fuse, voltage selector

The 1 A fuse for AC power source, and selector for source voltage. The source voltage is selected from 100, 120, 220, and 240 V AC.

(50) VHF ANT connector

This antenna connector (50 Ω) is used to receive VHF band with the aid of the optional V·UHF converter CMK-165. It is attached to the V·UHF converter.

(51) UHF ANT connector

This antenna connector (50 Ω) is used when the UHF band is received with the aid of the optional V·UHF converter CMK-165. It is attached to the V·UHF converter.

5. OPERATION

For functions of switches and controls, refer to Chapter 4 "Switches and Controls on panels".

5.1 Reception

This chapter describes fundamental use of the Receiver.

5.1.1 Preliminary Setting

When the antenna cable and power cables have been connected as shown in Fig. 3-1, turn on the POWER switch, and set the controls and switches as follows :

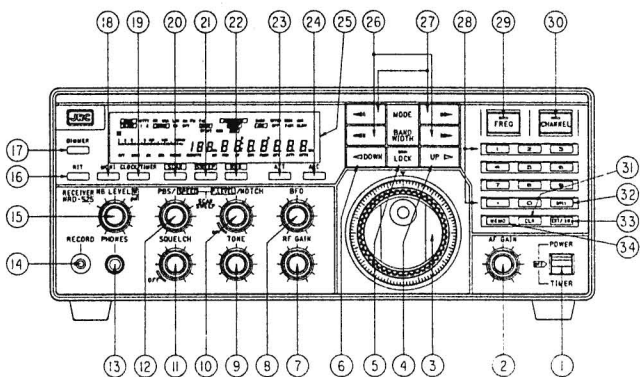

LOCK switch (5)OFF
AF GAIN control (2)Turn fully counterclockwise.
RF GAIN control (7)Turn fully clockwise.
TONE control (9)Neutral (central) position
NOTCH control (10)Turn fully counterclockwise.
SQUELCH control (11)Turn fully counterclockwise.
PBS (pass band shift) control (12)Set at Neutral position.
RIT switch (16)OFF
ATT (attenuator) switchOFF
NB LEVEL control (15)Turn fully counterclockwise.

5.1.2 Setting of Frequency

A frequency can be set by any of the following three methods :

- Setting of frequency with TUNING control (3)

Any frequency in the entire receiving frequency range can be set in 10 Hz steps. Ordinarily, the TUNING control is used to change the frequency by less than 1 MHz.

- Setting of frequency with UP switch (4) or DOWN switch (6)

Before use of these switches, turn on the FREQ switch (24). The frequency can be increased or decreased by the auto repeat function. These switches are helpful when you are going to search for signals in a relatively wide frequency range.

- Setting of frequency with numerical keys (28)

To enter the frequency data with numerical keys, either of the following two methods are used according to the unit of the frequency (kHz or MHz) :

In this example, 12.3456 MHz is entered.

- 1) Entry in kHz

Press the keys as :

- 2) Entry in MHz

Press the keys as :

If you have pressed a wrong key, press the CLR key (31) and start again. Pressing the CLR key (31) before pressing or clears the data just entered and the previously setting of the frequency becomes valid.

Once or key are pressed, CLR key becomes inoperative.

5.1.3 Reception of SSB Signal

The frequency of the suppressed carrier is indicated for both LSB and USB.

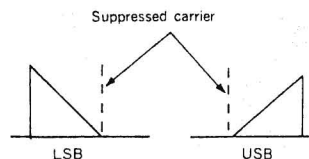

With the controls and switches set as described in 5.1.1, set the following controls and switches as specified :

MODE switch (27)LSB or USB
 BANDWIDTH switch (26)INTER
 AGC switch (24)SLOW
 AF GAIN control (2)Set for suitable sound volume.
 Receiving frequencySet to the desired frequency.

Slowly turn the TUNING control to find a point where the SSB signal can be clearly heard.

5.1.4 Reception of CW Signal

With the controls and switches set as described in 5.1.1, set the following controls and switches as specified :

MODE switch (27)CW
 BANDWIDTH switch (26)INTER
 BFO control (8)Neutral position
 AGC switch (24)FAST
 AF GAIN control (2)Set for suitable sound volume.
 Receiving frequencySet to the desired frequency.

Receive the CW signal, and adjust the TUNING control (3) so that the AF (audio) output signal gives zero beat. Then, turn the BFO control (8) clockwise or counterclockwise to obtain desired note. The tone from the AF (audio) output will become about 800 Hz if the BFO control is turned clockwise or counterclockwise by 1.5 division on the scale from the neutral position.

If the optional narrow band filter is mounted on the NARR, put the BANDWIDTH switch (26) to the NARR position. Then, interference and noise will be reduced.

5.1.5 Reception of AM signal

With the controls and switches set as described in 5.1.1, set the following switches and controls as specified :

MODE switchAM
 BANDWIDTH switch (26)WIDE
 AGC switch (24)FAST
 AF GAIN control (2)Set for suitable sound volume.
 Receiving frequencySet to the desired frequency.

If the BANDWIDTH switch is put to the AUX position when the optional narrow band filter is not mounted in the AUX position, the bandwidth will be set at 12 kHz and the quality of sound will be much improved.

5.1.6 Reception of RTTY Signal

The frequency indicated is the center frequency between the mark and space signals.

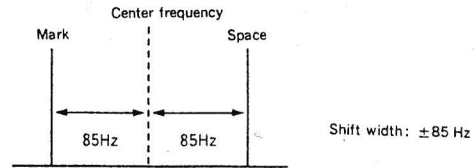

With the controls and switches set as described in 5.1.1, set the following controls and switches as specified :

MODE switch (27)RTTY
 BANDWIDTH switch (26)INTER
 AGC switch (24)FAST
 AF GAIN control (2)Set for suitable sound volume.
 Receiving frequencySet to the desired frequency.

If you tune the receiver correctly to the center frequency of the transmitted signal, the center frequency of the AF (audio) output becomes 2210 Hz.

For operation and connection to get a printer output with the use of the optional RTTY demodulator CMH-530, see instruction manual for the CMH-530.

5.1.7 Reception of FAX Signal

The indicated frequency is the center frequency between the mark and space signals.

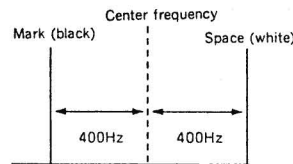

With the controls and switches set as described in 5.1.1, set the following controls and switches as specified :

MODE switch (27)FAX
 BANDWIDTH switch (26)INTER
 AGC switch (24)FAST
 AF GAIN control (2)Set for suitable sound volume.
 Receiving frequencySet to the desired frequency.

If you tune the receiver correctly to the center frequency of the transmitted signal, the center frequency for the AF (audio) output becomes 1.9 kHz.

To connect a FAX terminal, use the LINE OUT (output) jack on the rear panel.

5.1.8 Reception of FM Signal

The indicated frequency is the carrier frequency without modulation.

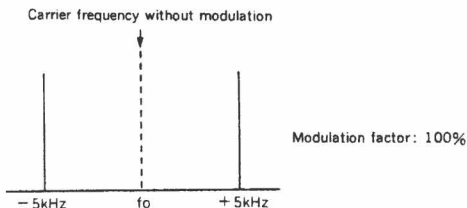

With the controls and switches set as described in 5.1.1, set the following controls and switches as specified :

MODE switch (27)FM
AF GAIN control (2)Set for suitable sound volume.
Receiving frequencySet to the desired frequency.

The FM signals which can be received in this mode are narrow band FM (with a frequency deviation of maximum 5 kHz). In this mode, the BANDWIDTH switch (26), and the AGC switch (24) are inoperative.

5.2 Use of Preset Memory

The NRD-525 can store 200 channels, with each channel containing the mode, bandwidth, attenuator on-off, and status of AGC. What is stored is backed up by the lithium battery.

5.2.1 Setting of Channel

The channel is set by either of the following two methods :

- Setting of channel with UP switch (4) or DOWN switch (6)

Before manipulating these switches, turn on the CHANNEL switch. IF the UP or DOWN switch is pressed, the channel number is increased or decreased.

- Setting of channel with numerical keys

For example, the channel No. 199 is set with numerical keys as follows.

Press the keys as : 1 9 9 ENT/kHz

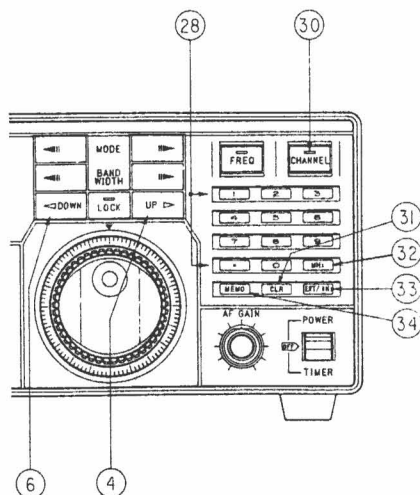

5.2.2 Storing

Data are stored by any of the following methods according to the order of setting of the frequency and channel number :

- To store the frequency first :

- 1) Turn on the FREQ switch (29), and set the frequency, mode, bandwidth, on-off of ATT, and AGC status which you want to store. (For setting of the frequency, see 5.1.2.)
- 2) Turn on the CHANNEL (30), and set the desired channel number. For example, the keys are used in the following manner to set the channel No. 199.

Press the keys as : 1 9 9

Do not press the ENT/kHz key at the moment. If it is pressed, what is stored in the channel No. 199 is indicated on the vacuum fluorescent display (25), and the newly set frequency, mode, bandwidth, on-off of ATT, and status of AGC are deleted.

- 3) Press the ENT/kHz switch (33) with the MEMO (memory) switch (33) depressed. Then, the beep sounds and what has been set is stored in the channel No. 199.

- To set the channel number first :

- 1) Turn on the CHANNEL switch (30), and set the desired channel number. (For setting of the channel number, see 5.2.1.)
- 2) Turn on the FREQ switch (29), and set the frequency, mode, bandwidth, on-off of ATT, and AGC status which you want to store. (For setting of the frequency, see 5.1.2.)
- 3) Press the ENT/kHz switch (33) with the MEMO (memory) switch depressed. Then, the beep sounds and what has been set is stored in the desired channel.

5.2.3 Reception with Memory Channel

Turn on the CHANNEL switch (30) , and set the desired channel number. (For setting of the channel number, see 5.2.1.)

When the channel number has been set, the data stored in that channel are displayed on the vacuum fluorescent display (25), and reception can be done according to the data. At this time, the characters "MR" (memory read) are illuminated. If the CHANNEL switch (30) is on, the channel number can be increased or decreased with the UP switch (4) or DOWN switch (6).

If the FREQ switch is turned on, the frequency stored can be changed with the TUNING control (3), UP switch (4) and DOWN switch (6). In this case, the characters "MR" on the display disappears, and the newly set frequency is used for reception.

5.3 Scan and Sweep

The scan function allows automatic scan among specified channels. The sweep function allows automatic sweep between specified edge frequencies.

5.3.1 Confirmation and Setting of Scan Start or End Channel

- **SCAN START**: Channel number at which the scan function starts scan.
- **SCAN END**: Channel number at which the scan function ends scan.

Press the SCAN switch (20) to select SCAN START or SCAN END. Then, the previously set channel number and data stored in that channel are indicated on the vacuum fluorescent display (25), and reception can be done according to these data.

To change the channel number setting, set the scan start or scan end channel number according to the procedures described in "5.2.1 Setting of Channel" after selecting SCAN START or SCAN END. Then, the set channel number and data stored in that channel are displayed on the vacuum fluorescent display (25), and reception can be done according to these data.

To exit and enter other operation, press either the CLOCK/TIMER switch (19), SWEEP switch (21), FREQ switch (29), or CHANNEL switch (30).

5.3.2 Confirmation and Setting of Sweep Start Frequency or Sweep End Frequency

- **SWEEP START**: Frequency at which the sweep function starts sweep.
- **SWEEP END**: Frequency at which the sweep function ends sweep.

Press the SWEEP switch (21) to select SWEEP START or SWEEP END. Then, the previously set frequency is displayed on the vacuum fluorescent display (25), and reception can be done at that frequency.

To change the frequency, select SWEEP START or SWEEP END, and set the sweep start or sweep end frequency according to "5.1.2. Setting of Frequency". Then, you can receive that frequency.

To exit and enter other operation, press either the CLOCK/TIMER switch (19), SCAN switch (20), FREQ switch (29), or CHANNEL switch.

5.3.3 Scan and Sweep

If the RUN switch (22) is turned on after the SCAN switch (20) is pressed to select and indicate SCAN START or SCAN END, scan starts at the start channel number.

If the RUN switch (22) is turned on after the SWEEP switch

(21) is pressed to select and indicate SWEEP START or SWEEP END, sweep starts at the start frequency.

While sweep or scan is being executed, the characters "RUN" are illuminated on the vacuum fluorescent display (25). Upon this, the characters "START" or "END" disappears. To temporarily stop the scan or sweep function, press the RUN switch (22). To re-start scan or sweep, press this switch again. Then, scan or sweep re-starts at the channel number or frequency at which scan or sweep was suspended. If the SCAN switch (20) or SWEEP switch (21) is pressed during scan or sweep, SCAN START or SWEEP START is selected, and scan or sweep is stopped.

During scan or sweep, the automatic pause can be set with the P•LEVEL (pause level) control (10).

If the P•LEVEL control (10) is turned fully clockwise, scan or sweep will be stopped by very weak signals. As the P•LEVEL control is turned counterclockwise, a stronger signal is needed to stop scan or sweep. In case the gain of the receiver is decreased with the RF GAIN control (7), automatic pause will not be effected unless the P•LEVEL control (10) is turned a little counterclockwise as compared with the full counterclockwise position of the RF GAIN control (7).

The scan or sweep speed can be set with the SPEED control (12). As the SPEED control (12) is turned clockwise, the scan or sweep speed increases.

CAUTION

1. During scan or sweep, the PBS (pass band shift) or notch filter does not operate.
2. After completion of scan or sweep, put the NOTCH control (10) to the OFF position, and put the PBS (pass band shift) control (12) to the neutral position.

5.4 Setting of Clock and Timer

The NRD-525 has two built-in clocks (CLOCK 1 and CLOCK 2). The power for the NRD-525 can be automatically turned on and off by the timer programmed based upon CLOCK 1. For simultaneous control of an external device, terminals connected to the relay contact are provided on the rear panel.

5.4.1 Display and Setting of Time

- **CLOCK1**: Time such as local time
- **CLOCK2**: Time such as UTC (Universal Coordinated Time)
- **TIMER ON**: Time at which the power for the NRD-525 is turned on when the CLOCK 1 indication reaches at the time pre-programmed.
- **TIMER OFF**: Time at which the power for the NRD-525 is turned off when the CLOCK 1 indication reaches at the time

pre-programmed.

Press the CLOCK/TIMER switch (19) to select either CLOCK 1, CLOCK 2, TIMER ON, or TIMER OFF. When it is selected, the time is indicated on the vacuum fluorescent display (25). At this time, the receiving frequency is not indicated, but reception can be done at the frequency already set before pressing of the CLOCK/TIMER switch (11). In this case, the settings concerning reception including the frequency, mode, and bandwidth excepting PBS and BFO (in the CW mode) cannot be changed.

To change time, select the desired kind of time with the CLOCK/TIMER switch (19), and set the time with numerical keys in the following manner :

For example, to set 13 : 23, press the keys 1 3 2 3, and press the ENT/kHz key on the correct time.

To set 3 : 45, press the keys 3 4 5, and press the ENT/kHz key on the correct time.

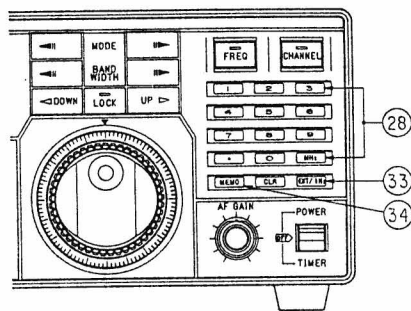

5.4.2 Calibrating CLOCK 1 within 30 Seconds

Press the CLOCK/TIMER switch (19) to select CLOCK 1. While pressing the MEMO switch (34), press the ENT/kHz switch (33) on the correct time (e.g. time broadcast).

Upon this, the digits of the second are reset to zero and the digits of the minute remain as they are if the digits of the second are between 0 and 29. If the digits of the second are between 30 and 59, the digits of the second are reset to zero, and the digits of the minute advance by "1". At this time, CLOCK 2 is also calibrated automatically.

5.4.3 Use of Timer

As an example of the use of timer function, suppose that unattended recording is performed under the following conditions :

Receiving frequency : 12.3456 MHz

Recording time : From 7 : 10 to 8 : 20 according to UTC

First, connect the tape recorder as shown in Fig. 5-2.

● Steps of unattended recording

- 1) Set CLOCK 1 at the current time according to UTC (Use the current time according to local time if recording is to be

done according to local time.)

- 2) Set TIMER ON time at 7 : 00.
- 3) Set TIMER OFF time at 8 : 20.
- 4) Set the receiving frequency at 12.3456 MHz.

Set the mode, bandwidth, AGC, and ATT if necessary.

- 5) Put the POWER/TIMER ON-OFF switch (1) to the TIMER position.

(Then, the timer function begins to work.) At this time, the vacuum fluorescent display (25) indicates the time for CLOCK 1 only, and only the DIMMER switch (17) remains effective.

- 6) Thus, setting is finished.

When the TIMER ON time "7 : 10" has been reached, the power for the NRD-525 is switched on, and recording started with the previously set receiving frequency, mode bandwidth, AGC status, and on-off status of ATT indicated on the vacuum fluorescent display (25). When the TIME OFF time "8 : 20" comes, the power for the NRD-525 switched off and recording is stopped.

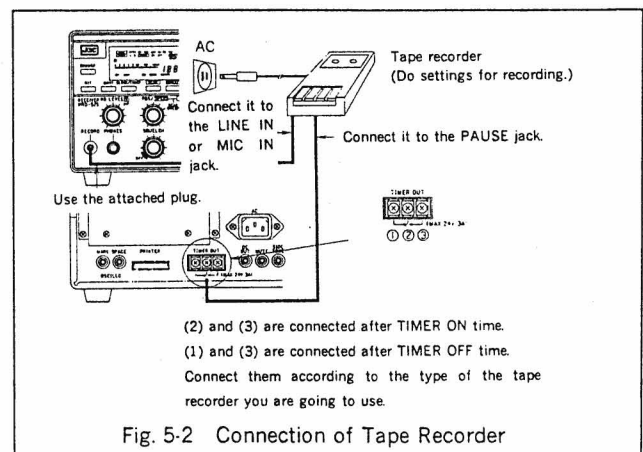

Fig. 5-2 Connection of Tape Recorder

Precautions in Use of Clock Timer

1. To exit and enter other operations, press either the SCAN switch (20), SWEEP switch (21), FREQ switch (29), or CHANNEL switch (30) according to your requirement.
2. If you have pressed the CLOCK/TIMER switch (19) to select TIMER ON or TIMER OFF, the timer will not work for the set time. To make the timer work again, put the POWER/TIME ON-OFF switch (1) to the TIMER position.
3. Even when the POWER/TIMER ON-OFF switch (1) is turned off, the clock is backed up. If the power cable is removed, the timer ceases to be backed up.
4. If the POWER/TIMER ON-OFF switch (1) is put to the TIMER position, do not manipulate the RF GAIN control (7), BFO control (6), TONE control (9), NOTCH control SQUELCH control, PBS (pass band shift) control (12), or

NB LEVEL (noise blanker) control before the receiver is re-activated by the timer.

5.5 Change of Operation by User Definition

Some operations of the NRD-525 can be changed by the user definition in the following manner.

● Frequency indication in USB/LSB mode

Each time the numerical key **0** is pressed with the **MEMO** key depressed, the frequency indication in USB/LSB mode is changed in following manners:

Indication shift

Frequency indication is shifted by 1.5kHz according to modes and output frequency of synthesizer is unchanged.

Local shift

Indication of frequency is unchanged but output frequency of synthesizer is shifted by 1.5kHz according to modes.

You can receive, without re-tuning, a lower or upper sideband of AM signal in LSB or USB mode respectively.

● Indication of 10 Hz digit of frequency

Each time the numerical key **1** is pressed with the **MEMO** key depressed, the indication of the 10 Hz digit of the frequency appears and disappears in turn. Before shipment, setting is done so that the 10 Hz digit is indicated.

● Blinking of colon in time indication

Each time the numerical key **2** is pressed with the **MEMO** key depressed, the colon blinks and stops blinking in turn. Before shipment, setting is done so that the colon blinks.

● Beeping upon pressing of key switch

Each time the numerical key **3** is pressed with the **MEMO** key depressed, sounding of the the beep is set and reset in turn. Sounding of the beep upon erroneous key operation and upon storing of data cannot be reset.

Before shipment, setting is done so that the beep does not sound when a key switch pressed.

● Bypass for input RF filters

Each time the numerical key **4** is pressed with the **MEMO** key depressed, the input RF filters are bypassed and inserted in turn.

When they are bypassed, characters "PASS" are displayed.

If you wish to remove the loss due to the input RF filters while receiving very weak signal, you can use this command.

● Change of tuning step

Each time the RUN switch is pressed, when the receiver is operated except SCAN/SWEEP mode (the indication of SCAN

and SWEEP are off state), the tuning step is changed to fine step or course step in turn.

○ Fine step

Tuning rate of the tuning knob is set to 2 kHz per revolution, and minimum increment step of the UP/DOWN switch is set to 1 kHz (5 kHz for FM mode).

○ Course step

Tuning rate of the tuning knob is set to 20 kHz per revolution, and minimum increment step of the UP/DOWN switch is set to 10 kHz (same for FM mode).

1/29/90 CHANGED
IC2 7DEJ0072
- WITH IC2 7DEJ0072A -

6. CIRCUIT DESCRIPTION

6.1 Outline

The block diagram and circuit diagram are respectively given in Chapters 10 and 11.

The NRD-525 can be broken down into the chassis, panel, receiver, synthesizer, and control blocks.

The chassis block consists of the power supply circuit, rear panel, and motherboard, which mutually connect various plug-in units. The power supply circuit feeds 5 V, 9 V, and 10.8 V to each unit.

The panel block has the controls and switches used for operation of the NRD-525. The large vacuum fluorescent display section indicates the frequency, mode, bandwidth, etc.

The receiver is of double superheterodyne type with a first IF frequency of 70.45399-70.453MHz and a second IF frequency of 455KHz. The received signal from the antenna is applied to the electronic tuning circuit in the RF TUNE unit, where undesirable signal components are suppressed. The signal which has passed the RF TUNE circuit is fed to the first mixer through the RF amplifier. The signal is mixed with the first local oscillator (70.543-104.453MHz) in the first mixer and converted into the first IF frequency of 70.45399-70.453MHz. This signal is mixed with the second local oscillator of 69.99899-69.998MHz and converted into the second IF frequency of 455kHz. The converted 455KHz signal passes through the IF filter, and is amplified and demodulated in the IF amplifier section. The demodulator SN16913 works as a synchronous detector in the AM mode, and works as the product detector in any other mode. In the FM mode, the FM detector MC3361 is used. The demodulated low frequency signal is amplified by the AF amplifier to a level suitable for driving the speaker.

The synthesizer block generates the first local oscillator frequency of 70.543-104.453 MHz, the second local oscillator of 69.99899-69.998MHz, and BFO signal from the standard frequency of 12.8MHz.

The control block controls the panel, receiver, and synthesizer blocks with the aid of the microcomputer.

6.2 Units

The following plug-in units are provided as standard units.

1) HF tune unit CFL-205

This unit includes the electronic tuning system, RF amplifier circuit, and a first mixer circuit.

2) IF filter unit CFH-36

This unit includes a first IF filter (MCF), a second mixer circuit, noise blanker circuit, and a second IF filter for the receiver block. The optional IF filter is mounted on this unit if necessary.

3) IF AF amplifier unit CAE-182

This unit includes a notch filter circuit, IF amplifier circuit, AF amplifier circuit, FM detector circuit, AGC amplifier circuit, and squelch circuit for the receiver block.

4) Loop 1 unit CGA-131

The unit generates the first local oscillator signal by a phase-locked loop (PLL) synthesizer. The signal covering 70.543-104.453MHz in 1-kHz steps is fed to the first mixer.

5) Loop 2 unit CGA-132

The unit generates the second local oscillator signal and BFO signal by a PLL synthesizer. The second local oscillator signal covering 69.99899-69.998MHz is fed to the second mixer.

The frequency of the BFO signal varies according to the receiving mode in the following manner.

Mode	BFO frequency
CW	455±2kHz or more
USB	456.5kHz
LSB	453.5kHz
FAX	456.9kHz
RTTY	457.21kHz

6) CPU unit CDC-353

This unit includes the microprocessor and its peripheral circuits, which control the panel, receiver, and synthesizer blocks.

7) Date I/O unit CMH-632

The unit includes the standard oscillator (12.8MHz), counter for the synthesizer, and I/O ports for the microprocessor.

7. ADJUSTMENT AND MAINTENANCE

The NRD-525 you have purchased is properly adjusted and strictly tested before shipment. Ordinarily, no adjustment is needed.

Detailed adjustments excepting adjustments described below require special expertise. So, whenever you think that the Receiver requires such adjustments, contact the nearest JRC dealer or branch.

7.1 Adjustment

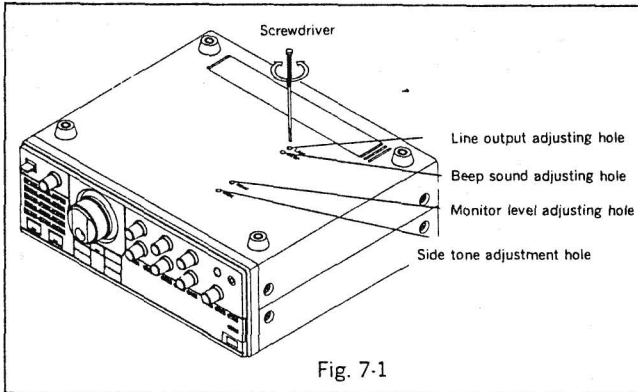

1) Line output level adjusting hole

Through this adjusting hole the output level of the LINE OUT (output) jack (38) on the rear panel, and the output level of the RECORD jack (14) can be adjusted with a screw driver. Upon shipment, it is set at about 0dBm.(1mW in 600 Ω)

2) Beep sound adjusting hole

The beep sounds for warning if you have pressed an erroneous key during entry of data. Through this hole the sound volume of the beep can be adjusted with a screw driver. Set the sound volume at any value you want.

3) Monitor level adjusting hole

The mute level in monitoring of your own transmission can be adjusted through this hole.

4) Side tone adjusting hole

Adjust the side tone input level in case the Receiver is used combinedly with a transmitter.

7.2 Maintenance

1) Parts

Be careful in handling ICs, transistors, and diodes because momentary short-circuiting will damage them.

2) Fuses

If the power fuse has blown, trace the cause of the trouble

before replacement. The AC power fuse is located on the rear panel. The DC power fuse is mounted on the power cable.

3) Lithium battery CR-2032FT6 (produced by Sanyo)

It is used for backup of the memory channels. The life of the battery is about five years.

If the life of the battery has been expired, the contents in the memory become corrupted or it becomes impossible to store data in the memory during operation. In this case, replace the battery immediately. The model of the lithium battery is CR-2032FT6 (3 V).

If the battery is unavailable or you want to ask somebody to replace the battery, contact the nearest JRC dealer or branch.

● Replacement of lithium battery

- (1) Remove the power cable from the Receiver.
- (2) Remove the upper cover as shown in Fig. 9-1.
- (3) Remove the CPU unit CDC-353 as shown in Fig. 9-2.
- (4) Replace the lithium battery as shows in Fig. 7-2.
- (5) Put back the CPU unit CDC-353 to the original position by pushing it along the rail securely.
- (6) Replace the upper cover.

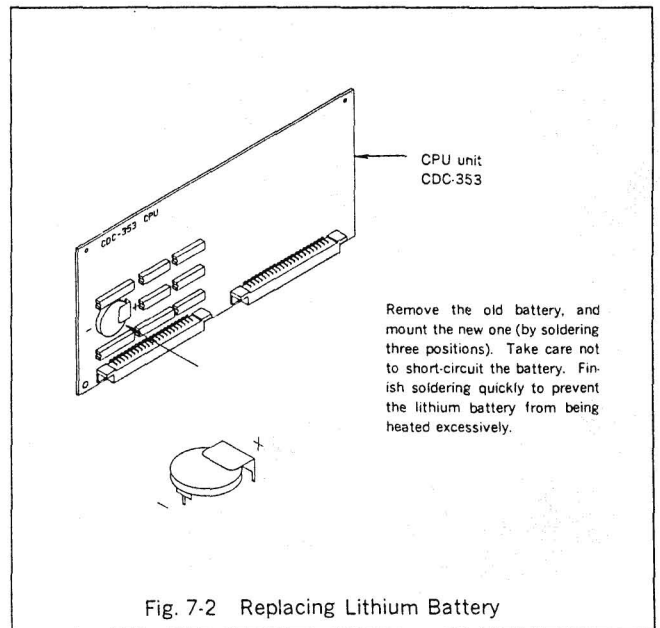

CAUTION

1. Note that the contents in the preset memory may be changed or lost after replacement of the battery.
2. In this case, please store data again referring to paragraph 5.2.2.

8. TROUBLESHOOTING

The NRD-525 has so many functions that the user may make operational errors. Before concluding that the Receiver has failed, read through the operating procedures described in this manual.

Here, various phenomena caused by erroneous handling are discussed. They are not faults. Before asking for repair, find the cause and take proper measures. If the Receiver will not work normally even after that, contact the nearest JRC dealer or branch.

8.1 Simple Trouble

No.	Phenomenon	Cause	Remedy
1	Indicators will not come on when power switch is turned on.	1) Improper insertion of power connector. 2) Fuse has blown.	1) Check connector. 2) Find cause and replace it with one having the same rating.
2	Indicators are lit but sound is not heard.	1) Headphone is connected to PHONES jack. 2) Squelch is closed. 3) RF GAIN control is turned fully counterclockwise.	1) Remove headphone. 2) Turn off squelch. 3) Turn it fully clockwise.
3	Illumination of vacuum fluorescent display is dim.	DIMMER control is put to minimum position.	Make it bright with DIMMER control.
4	S meter reads even when no signal is received.	RF GAIN control is not turned fully clockwise.	Turn RF GAIN control fully clockwise.
5	Receiving sound is distorted and difficult to understand.	1) AGC is turned off. 2) Tuning frequency is incorrect. 3) Mode switch is not put to proper position. 4) Notch filter is turned on. 5) Pass band shift control is not put to central position. 6) Noise blanker is switched on.	1) Put AGC control to FAST or SLOW position. 2) Do tuning again. 3) Put mode switch to suitable position according to receiving signal. 4) Turn off notch filter. 5) Put it to neutral position. 6) Turn noise blanker control fully counterclockwise.
6	Sensitivity is low.	1) ATT is turned on. 2) Antenna is not connected.	1) Turn off ATT. 2) Connect antenna properly. Ascertain that antenna selector switch on rear panel is put to proper position.

8.2 Complicated Trouble

8.2.1 Abnormal Indication and Abnormal Reception

If PCBs are disturbed during transportation, they will be improperly connected to the connectors on the motherboard, and

abnormal indication, abnormal reception and various other troubles may result. In this case, remove the upper cover as shown in 9.1.1 and fit each PCB securely by pushing it from above.

8.2.2 Entry of Noise into TV, Radio or Stereophonic

Player

The Receiver is provided with sufficient electromagnetic shielding, but it may cause noise interference to other electronic devices due to incomplete grounding, or antenna location. In this case, take the following measures to prevent such interference.

- 1) Replace the grounding conductor with a thicker and shorter one, and connect it to the nearest water pipe or copper plate buried under ground.
- 2) Put the antenna for the electronic device being interfered with away from the antenna of the NRD-525.
- 3) If the affected device is a TV or FM receiver, adjust the direction of its antenna or replace the antenna with one having better performance.
- 4) Take the power for the Receiver from some other plug receptacle.
- 5) Replace the grounding conductor for the affected device with a thicker one.
- 6) Mount a noise filter or isolation transformer on the power line.

8.2.3 Entry of Artificial Noise into Receiver

In addition to pulse noise due to lightning, rain, or snow, noise from a transmission line, high frequency sewing machine, personal computer, fluorescent lamp, hair dryer, etc. may affect the receiver. If there is any other transmitting antenna near the receiver, noise may come only when that transmitter is working.

Fundamentally, such artificial noise must be eliminated by correction made on the part of the noise source. However, noise may be sometimes eliminated by change of the shape or location of the receiving antenna for the NRD-525. Also, complete grounding may eliminate noise.

If the field strength of the desired signal you want to receive is sufficiently high, no noise will interfere with your reception.

8.2.4 Interference due to Intermodulation

In an area where several medium-frequency broadcasting stations which emit strong carriers are located, broadcasting from more than two stations may be received at a time at such a frequency that should not allow reception of these stations. This phenomenon is called intermodulation. If there seems to be intermodulation, turn on the ATT switch on the Receiver. If this will not eliminate interference, decrease the antenna height or shorten the antenna. Then, trouble will be eliminated in most cases.

8.2.5 Too Low Sensitivity of Receiver

In the HF band, the field strength for the signal from the same station greatly changes according to the frequency, time, season, and number of sunspots. To compare the sensitivity of receivers,

they must be connected to the same antenna and tuned to the same frequency at the same hour, then the S/N ratio of two receivers may be compared.

Also, the sensitivity may depend on the sound quality of the speaker. If you feel that the sensitivity of the Receiver is low, confirm the selection of the frequency and directivity of the antenna.

9. OPTION

9.1 Option

For additional convenience and effective use of the NRD-525, the following options are available:

■ RTTY demodulator unit CMH-530

This unit allow reception of RTTY and printing the received messages on the printer.

Shift width: $\pm 85 \text{ Hz}, \pm 200 \text{ Hz}, \pm 425 \text{ Hz}$ (selected with numerical keys on the front panel)

Transmission rate: 45.45 or 50 Bauds(selected with numerical keys on the front panel)

NOTE: The printer must be provided by the customer at his own cost if necessary.

■ RTTY connection cable 6ZCJDO0139

This is a cable to connect the NRD-525 and the printer. connector of printer side has 36 pins.

■ RS-232C interface unit CMH-532

This is used to remotely control the NRD-525 from an external device (such as personal computer).

■ RS-232C connection cable 6ZCJDO0140

This is a cable to connect the NRD-525 and external device (such as a personal computer).

Connector of external device side has 25 pins.

■ IF filter

This is a narrow band crystal filter.

The following types are available :

- CFL-231(YF 455FM) —6dB bandwidth 240Hz or more
- CFL-232(YF455DQ) —6dB bandwidth 0.5-0.8kHz
- CFL-233(YF455DE) —6dB bandwidth 1KHz-1.5kHz
- CFL-218A(YF455EBF) —6dB bandwidth 1.7-1.9kHz

■ Speaker NVA-88

This large type speaker has a design matching that of the receiver.

■ Headphone ST-3

Specially designed for communication use.

9.2 Installation of Opions

Before starting work, be sure to remove the power cable. Do not remove units unless absolutely necessary.

1) Removing cover

As shown in Fig. 9-1, remove the upper cover or lower cover by loosening four screws.

The speaker is mounted on the upper cover. Remove the upper cover slowly, taking care not to break the speaker cables. Remove the connector at the end of the cable from the internal unit if necessary.

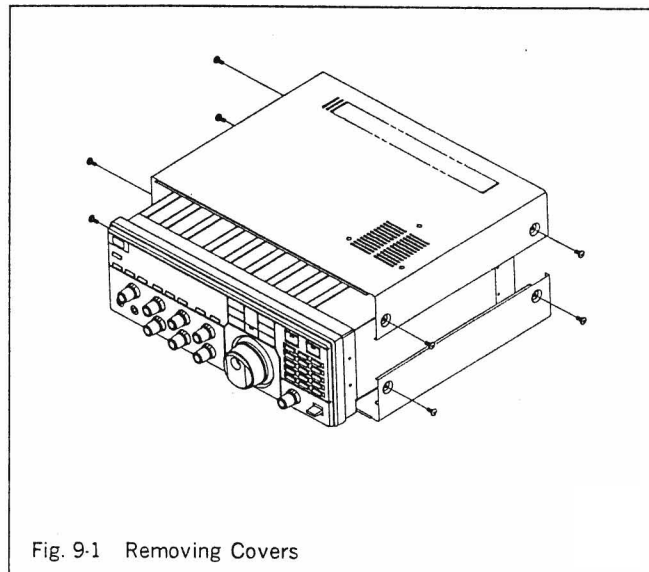
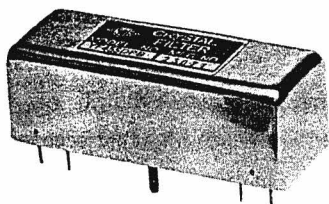

Fig. 9-1 Removing Covers

2) Removing internal units

Each unit is located as shown in Fig. 9-3.

- (2) From the parts mounted side, insert the removal levers supplied with each option into the holes at both corners of the PCB.
- (2) Lower the removal lever carefully so as to lift up the PCB.
- (3) When the PCB has been removed from the connector, lift it slowly to remove it.



Crystal filter

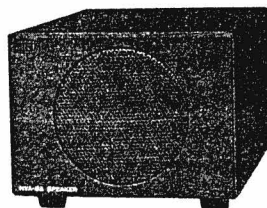

NVA-88



ST-3

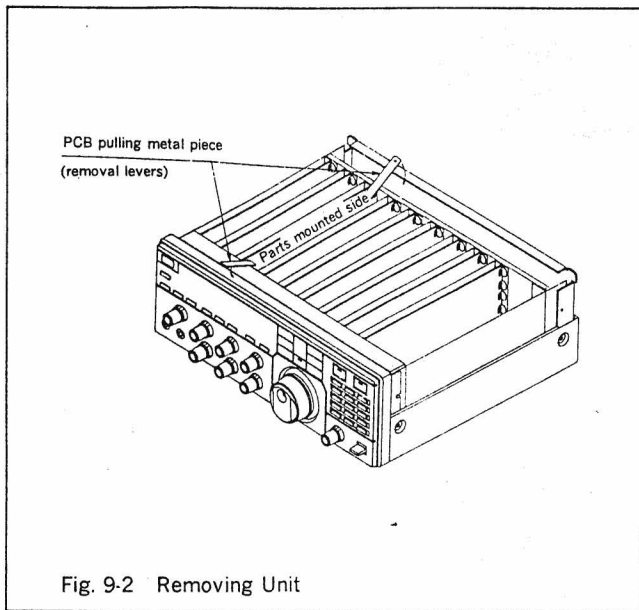

Fig. 9-2 Removing Unit

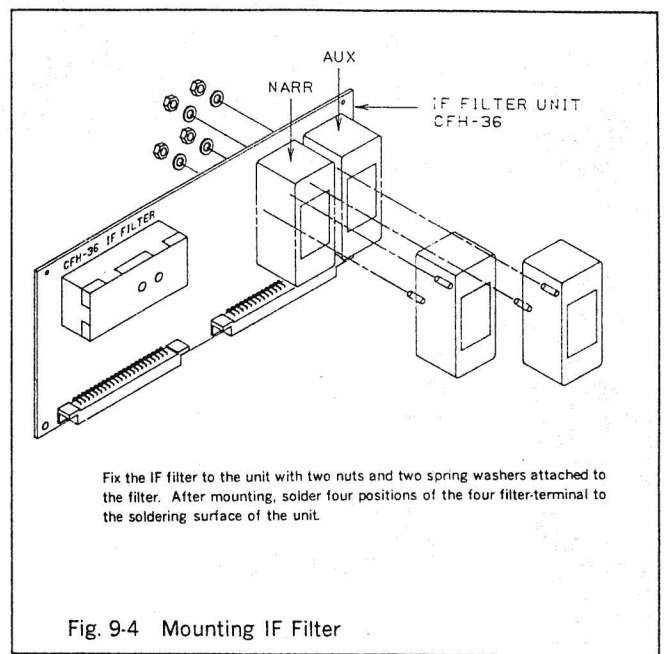

Fig. 9-4 Mounting IF Filter

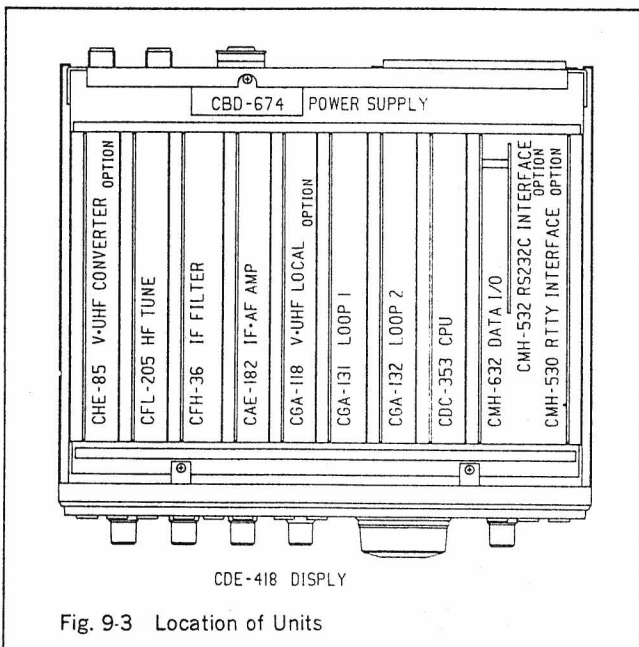

Fig. 9-3 Location of Units

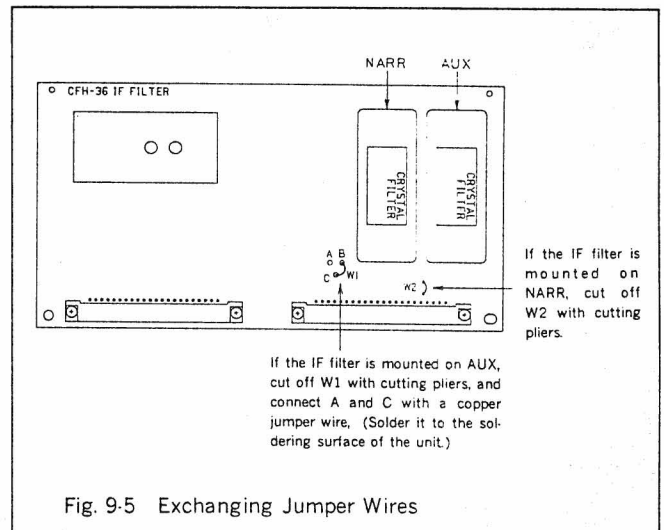

Fig. 9-5 Exchanging Jumper Wires

3. Mounting of IF Filter

A total of two filters can be mounted additionally in the IF filter unit CFH-36 corresponding to the NARR and AUX of the bandwidth switch.

- (1) Remove the upper cover.
- (2) Remove the IF filter unit CFH-36 from the Receiver.
- (3) Mount the IF filter as shown in Fig. 9-4.
- (4) Exchange jumper wires as shown in Fig. 9-5.
- (5) Put back the IF filter unit CFH-36 to the original position by securely inserting it along the rail.
- (6) Mount the upper cover.

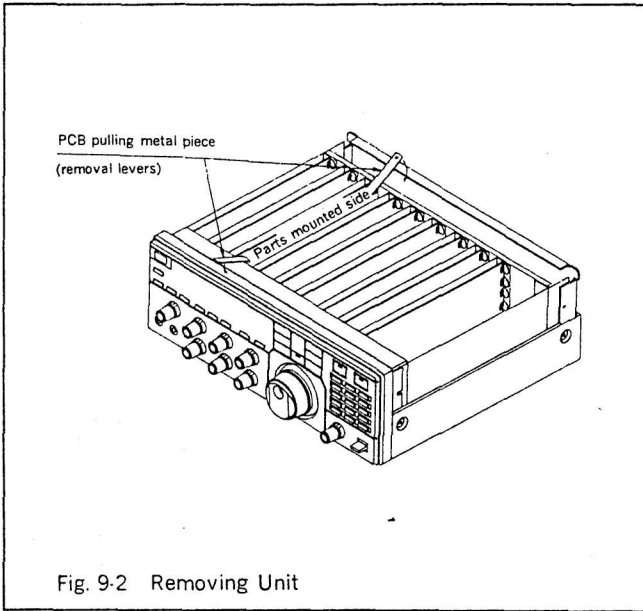
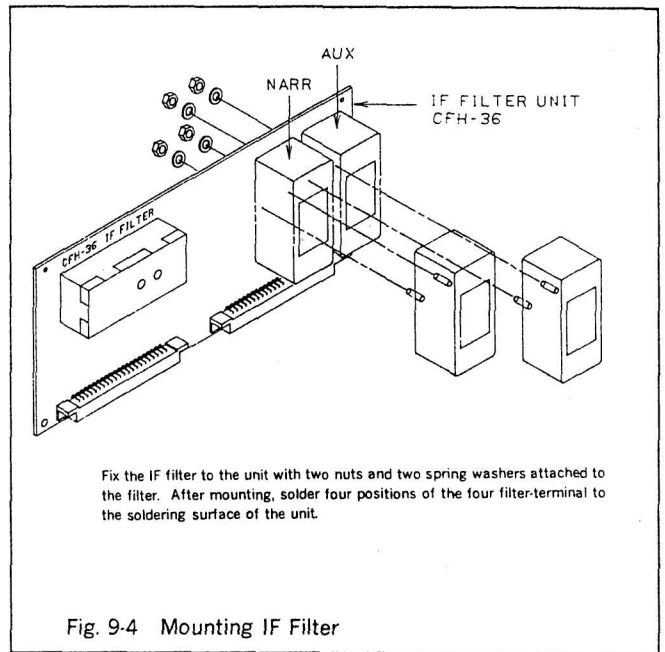

Fig. 9-2 Removing Unit



Fix the IF filter to the unit with two nuts and two spring washers attached to the filter. After mounting, solder four positions of the four filter-terminal to the soldering surface of the unit.

Fig. 9-4 Mounting IF Filter

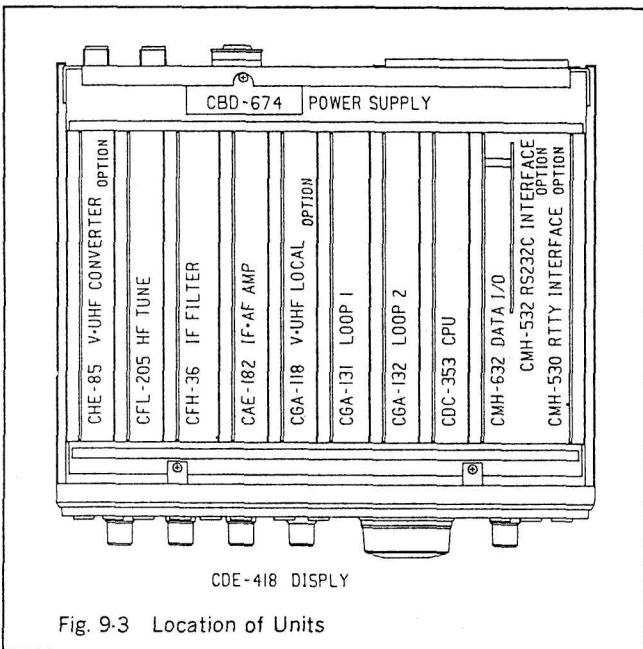

Fig. 9-3 Location of Units

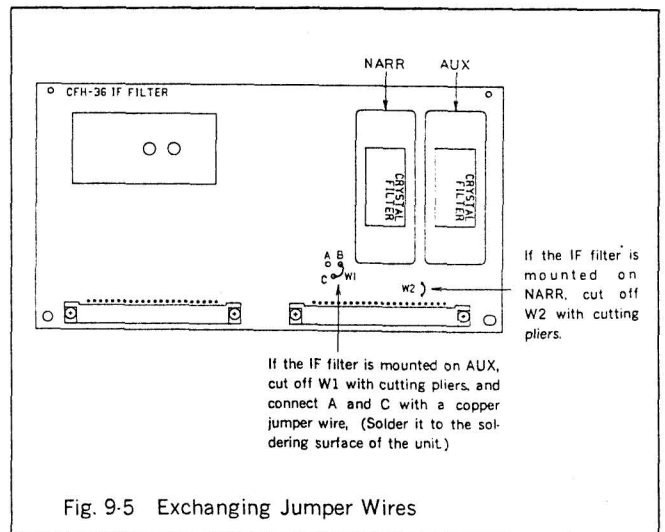

Fig. 9-5 Exchanging Jumper Wires

3. Mounting of IF Filter

A total of two filters can be mounted additionally in the IF filter unit CFH-36 corresponding to the NARR and AUX of the bandwidth switch.

- (1) Remove the upper cover.
- (2) Remove the IF filter unit CFH-36 from the Receiver.
- (3) Mount the IF filter as shown in Fig. 9-4.
- (4) Exchange jumper wires as shown in Fig. 9-5.
- (5) Put back the IF filter unit CFH-36 to the original position by securely inserting it along the rail.
- (6) Mount the upper cover.