

**JRC**

# HF LINEAR AMPLIFIER **JRL-2000F**



**JRC**

*Japan Radio Co., Ltd.*

# INTRODUCTION

Thank you for purchasing the JRL-2000F, the world's first MOSFET HF linear amplifier. JRC has designed and produced the JRL-2000F based on its many years of achievements and experience with professional transmitters and has taken advantage of the latest design technology. Please read this manual carefully before operating your new amplifier.

The JRL-2000F has been manufactured under the strictest quality control conditions. Should you find any damage to the amplifier or encounter any other problems, contact your dealer or nearest JRC representative.

## ACCESSORIES

Each JRL-2000F is shipped with the following accessories:

■ Instruction manual .....	1
■ Remote Control Unit (NCH-365) .....	1
■ Main fuse (15A) .....	2
■ Power amplifier unit fuse (15A) .....	2
■ Control cable plug and plug casing .....	1
■ Dry cell batteries for remote control .....	2

Please check to make sure that all of the above items were received with your JRL-2000F.

# CONTENTS

<b>1. FEATURES .....</b>	<b>1</b>
<b>2. SPECIFICATIONS .....</b>	<b>3</b>
<b>3. BEFORE USING THE JRL-2000F .....</b>	<b>4</b>
3.1 Installation Location .....	4
3.2 Power Supply .....	4
3.3 Exciters .....	5
3.4 Antennas .....	5
3.5 Grounding .....	5
<b>4. CONNECTION .....</b>	<b>6</b>
4.1 Connection to a JST-135 transceiver .....	7
4.1.1 Connection diagram .....	7
4.1.2 Control cable wiring diagram .....	8
4.2 Connection to a Non-JRC Exciter .....	9
4.2.1 Connection diagram .....	9
4.2.2 Control cable wiring diagram .....	10
<b>5. OPERATING CONTROLS AND FUNCTIONS .....</b>	<b>14</b>
5.1 Front Panel Controls .....	14
5.2 Rear Panel Controls .....	15
5.3 Remote Control Unit (NCH- 365) .....	16
<b>6. BASIC OPERATION .....</b>	<b>17</b>
6.1 Preparation .....	17
6.2 Operation Modes .....	17
6.2.1 Operation of the POWER SUPPLY CONT. switch .....	18
6.2.2 Antenna switch mode .....	18
6.2.3 Antenna tuner mode .....	19
6.2.4 Linear amplifier mode .....	20
6.3 Automatic Tuning Operation .....	21
6.3.1 Automatic tuning procedures .....	22
6.3.2 JRL-2000F band assignment table .....	24
6.4 SET Operation .....	25
6.5 Switching Antennas .....	27
6.6 Adjusting the ALC Level .....	28
6.7 Memory Backup .....	30
6.8 Precautions .....	31
<b>7. SPECIAL OPERATIONS .....</b>	<b>32</b>
7.1 Erasing Preset Data .....	32
7.1.1 Erasing all data for a selected antenna .....	32
7.1.2 Erasing all data for a selected frequency band .....	32
7.2 Write-protecting for Preset Data .....	33
7.3 Using the JRL-2000F as a Dummy Load .....	33
7.4 Using More than 4 Antennas .....	34
7.5 Setting the DIP Switches .....	35
<b>8. PROTECTION FUNCTIONS .....</b>	<b>36</b>
8.1 Cooling Fans .....	36
8.2 Causes of Alarms and Corrective Measures .....	36

---

<b>9. PRECAUTIONS FOR MAINTENANCE AND OPERATION .....</b>	<b>38</b>
9.1 Cleaning the Main Unit .....	38
9.2 Maintenance of the Internal Circuits .....	39
9.3 Radio Interference Precautions .....	39
9.4 Precautions Against Power Surge Caused by Lightening .....	39
<b>10. PROBLEM SOLVING .....</b>	<b>40</b>
10.1 After-sales Service .....	40
10.2 Troubleshooting .....	40
<b>11. OPTIONS .....</b>	<b>41</b>
<b>12. ATTACHED DIAGRAMS .....</b>	<b>42</b>
12.1 External View .....	42
12.2 Block Diagram .....	42
12.3 Connection Diagrams .....	42

# 1 FEATURES

## ● 48 RF Power MOSFETs

The power amplifier unit is equipped with 4 wide-band amplifier circuits (2SK408/2SK409), each incorporating 12 high-voltage resistant RF power MOSFETs. As output gain is achieved by electrically combining the output from these broad-band amplifiers, sufficient output margin is available so that high-quality full duty cycle output throughout the entire power range is possible.

## ● SEPP-type Low Distortion Power Amplifier

Single ended push-pull (SEPP) circuits are employed. SEPP circuits do not have any of the shortcomings of conventional transistor-type push-pull circuits, so the JRL-2000F obtains high output power with superior IMD characteristics.

## ● Fully Automatic Antenna Tuner

The JRL-2000F is equipped with a fully automatic, instantly switching antenna tuner which converts the composite elements in the matching circuit to the binary system. By storing matching data for each antenna in the amp's high-capacity memory, antenna matching can be done instantaneously.

## ● Automatic Antenna Selector

Up to four antennas can be connected and selected by front panel switches. The selected antenna setting can be stored in memory along with the matching data for the antenna tuner to allow instant QSY.

## ● Automatic Frequency Counter System

A built-in frequency counter automatically reads the frequency of the input signal from the exciter and selects the correct frequency band. Manual band changing is not required and any exciter can be used with the JRL-2000F.

## ● High-Efficiency Switching Power Supply with PFC

The power supply for the JRL-2000F is equipped with a Power Factor Corrector (PFC) which corrects the AC input waveform to a sine wave by using the active smoothing circuit method. This increases the AC line power factor, which previously attained only 50-60%, to almost 100%. This means that power consumption has been nearly halved compared to other conventional power supplies. With its high-efficiency MOSFET switching regulator, a maximum continuous power supply output of 2.4 kW can be achieved when this exceptionally powerful unit is connected to 220 ~ 240V AC.

## ● Low Noise Design

The power amplifier and the power supply unit are equipped with MOSFETs which have higher heat-resistance properties. This reduces the operating time of the cooling fans significantly. A low noise axial fan mounted in the rear or the chassis also contributes to noise reduction. Additionally, a full break-in circuit with a compact relay housed in a shielded case reduces relay operating noise.

# 1 FEATURES

---

## ● Various Protection Circuits

The JRL-2000F incorporates several protection facilities in order to protect the circuitry against internal and external stresses and overloads such as overdrive and abnormal output loads. When one of the protection circuits is actuated in the PA unit, the gate bias of the power MOSFETs are directly controlled, without slow-operating ALC feedback, in order to reduce the power output. Therefore, should the ALC line not be connected, the PA unit will not suffer any damage.

# 2 SPECIFICATIONS

Operating frequency bands	: 1.8, 3.5, 7, 10, 14, 18 & 21 MHz amateur bands. (24 & 28 MHz bands: antenna tuner only)
Rated output power	: SSB 1 kW PEP* 100% duty cycle, 24 hour. CW 1 kW* 100% duty cycle, 24 hour. FSK/SSTV 1 kW* 100% duty cycle, 1/4 hour
Output impedance	: 50 $\Omega$ unbalanced, VSWR 3.0 (16.7–150 $\Omega$ )
Harmonics	: -60dB or less
Intermodulation distortion (IMD)	: -35dB or less below PEP (at 1 kW output)
Input impedance	: 50 $\Omega$ unbalanced
Exciting power	: 100W max.
Frequency switching time	: Less than 0.1 sec.
Power supply voltage	: 85 to 264V AC, single-phase
Power consumption	: 2.5 kVA or less (at 1 kW output)
Input power factor	: 95% or more (at 1 kW output)
Temperature range	: -10° to 40°C
Protection circuits	: PA excess current; PA overheat; PA abnormal load; AC power supply excess voltage; power supply overheat; PA failure; excessive antenna VSWR; exciting power excess; and antenna matching anomaly.
Dimensions	: 430(W) × 300(h) × 402(D) mm
Weight	: Approx. 28 kg

\* Note: Rated output on 200–240V AC. The rated output power on 100–120V AC is 750 W PEP

# 3 BEFORE USING THE JRL-2000F

## 3.1 Installation Location

When determining a location for installing the JRL-2000F, please take the following criteria into consideration:

- Avoid a place that is exposed to direct sunlight or susceptible to overheating.
- Avoid humid or dusty places.
- Do not place containers holding water or other liquids above or on top of the JRL-2000F.
- The JRL-2000F draws cooling air in from the front panel and expels it from the rear. Therefore, do not place any objects within 15 cm of the front and rear panels of the amplifier.

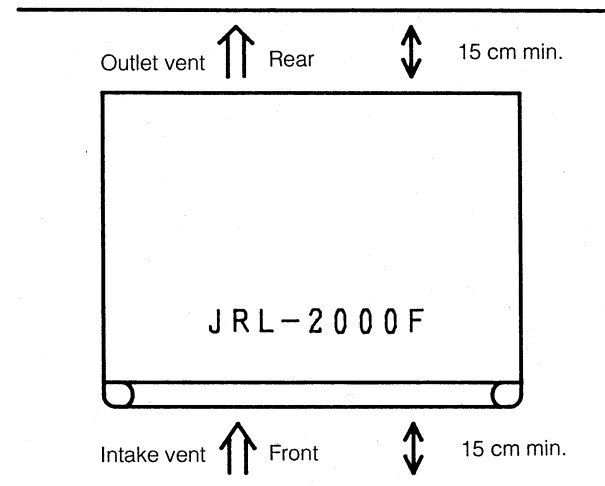

- Use a sturdy table or platform that can easily support the weight of the JRL-2000F (approximately 28 kg).

## 3.2 Power Supply Requirements

The JRL-2000F consumes approximately 12A of electrical current at an output power of 1000 W when power is supplied at 220 VAC. This must be taken into consideration, along with the consumption of the exciter, accessories and other home appliances, when choosing an AC line of sufficient capacity.

For full 1 kW output power a 200–240 VAC line must be used. If a 100–120 VAC line is used, the maximum rated RF output power is 750W.

If the power outlet has a ground terminal, be sure that the black wire is connected to ground.



### **3.3 Exciters**

Any HF-band transmitter or transceiver with a 50 $\Omega$  RF output impedance can be used as an exciter for the JRL-2000F. When used with the Japan Radio Co. JST-135 HF transceiver, additional control features can be utilized to enhance automatic band changing and tuning.

If the maximum output of the exciter exceeds 100W, the over-current protection circuit in the power supply unit may be activated and the output waveform may be distorted. Therefore, it is necessary to connect an external ALC signal in order to control the exciter output.

### **3.4 Antennas**

It is recommended that you select antenna(s) that meet the following criteria:

- Antenna impedance is 50 $\Omega$ .
- When using a beam or vertical antenna equipped with trap coils or balun transformers, be sure that they are capable of handling at least 1.5 kW PEP input.
- Use a coaxial cable with sufficient current capacity for all antenna connections.
- If the antenna VSWR value is too high the antenna wave radiation factor drops. Also, in case of a mismatch of the coaxial cable and antenna, undesired RF radiation may occur, possibly causing radio interference. Therefore, special care must be taken in order to avoid these problems.

### **3.5 Grounding**

To prevent electric shock and interference with other devices, connect your JRL-2000F and all other radio devices to a proper external grounding system. Use the heaviest possible copper wire, braid or strap and follow the shortest possible route. Do not use any gas pipe, water pipe or cable duct as a ground.

# 4 CONNECTION

---

Before connecting the JRL-2000F to an exciter, turn off the power of each radio device and unplug all power cords from the outlets.

Different methods of connection are used for different types of exciters. Interfacing the exciter to the JRL-2000F is accomplished by connecting various types of signal lines to the control connector as well as connecting the coaxial cable and grounding cable.

## 4.1 Connection to a JST-135 Transceiver

To connect you JRL-2000F to a JST-135 transceiver, the optional CFQ-3890 Control Cable can be used. You may also construct your own custom control cable according to the wiring diagram shown in section 4.1.2 of this manual.

### 4.1.1 Connection diagram

The following diagram illustrates the proper connection of control cable, antennas, and ground cable when the JRL-2000F is used with a JST-135 Transceiver.

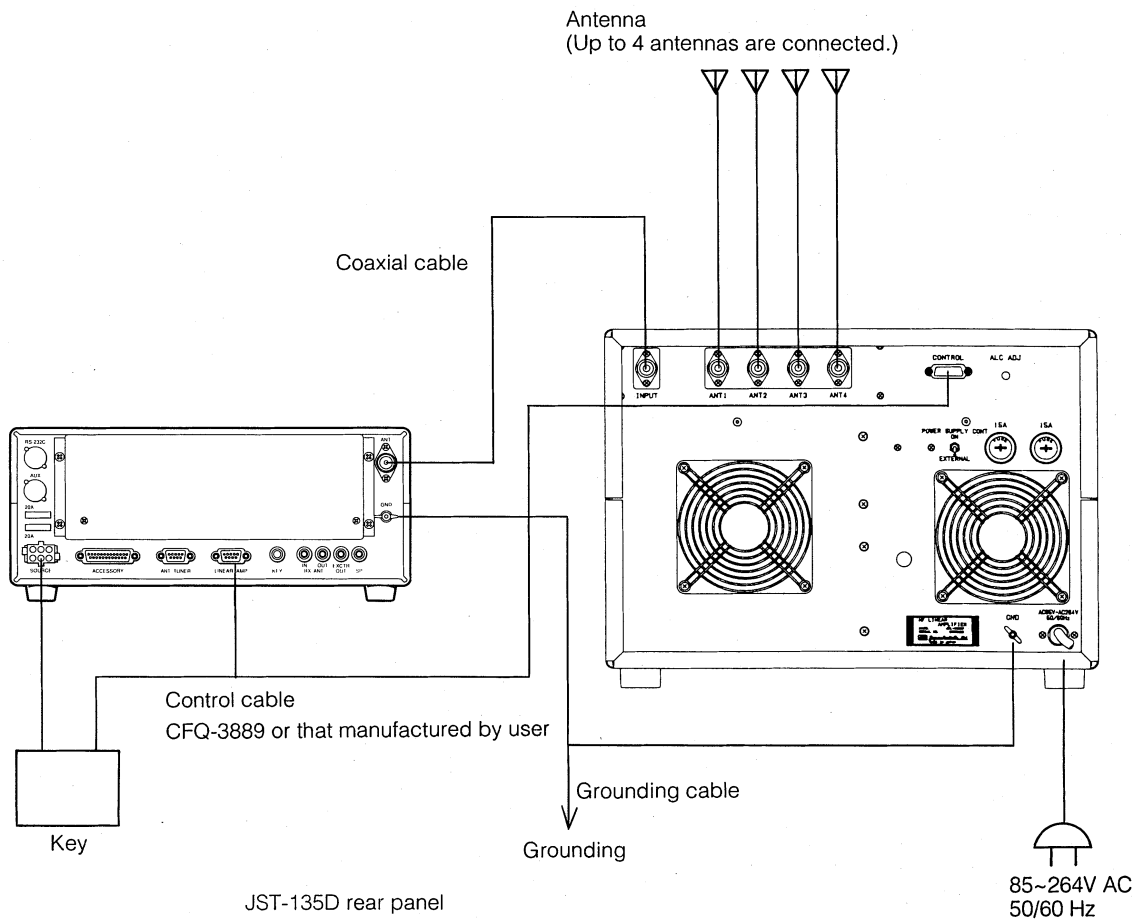

#### **Important**

The same type of connector is used for both the LINEAR AMP terminal and ANT TUNER terminal on the rear panel of the JST-135. Be very careful to connect the JRL-2000F's control cable to the LINEAR AMP terminal to avoid serious malfunctions.

# 4 CONNECTION

## 4.1.2 Control cable wiring diagram

If you choose to construct your own custom control cable instead of using the optional CFQ-3890 Control Cable, please follow the following wiring diagram.

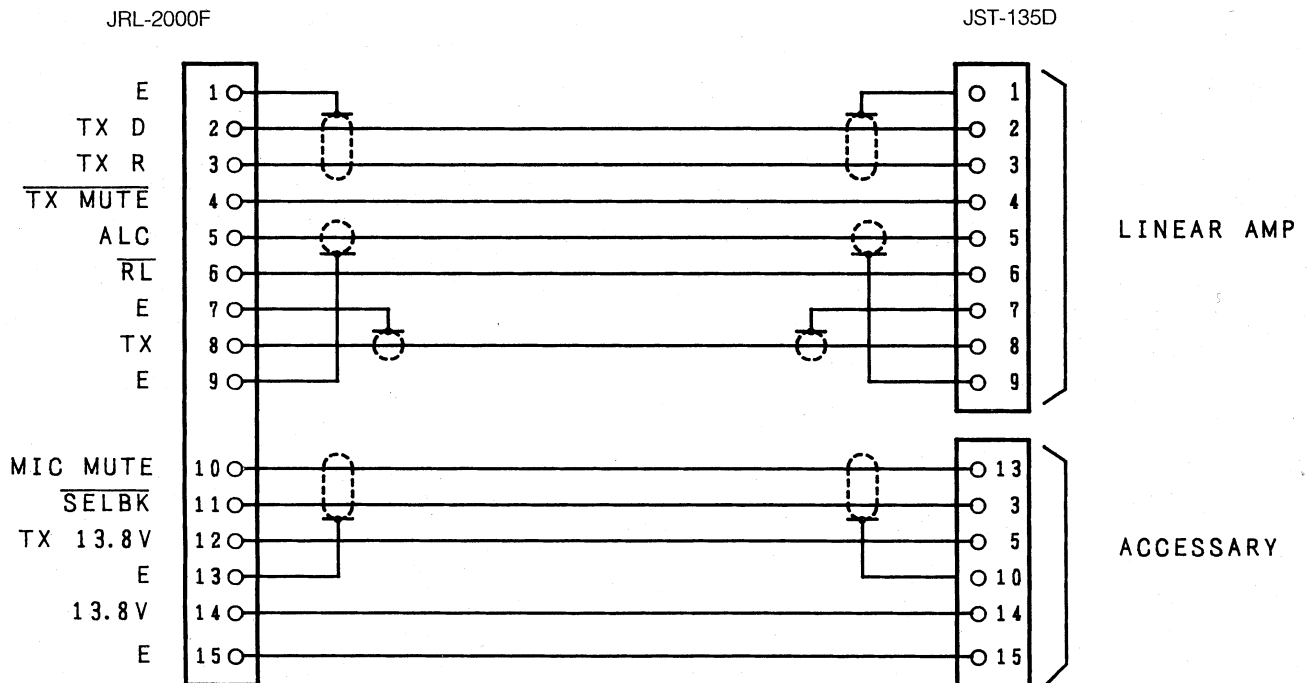

If the JST-135's ACCESSORY terminal can not be used (for example, if it is already used for another application), it is not necessary to connect to this terminal. However, in this case the following should be noted:

- Automatic antenna tuning can not be implemented unless the mode is set to CW and keyed down; and,
- The JRL-2000F can not sense when the JST-135's power switch is turned on and off, so the amplifier's power supply must be switched on and off manually via front panel switch or NCH-365 Remote Control Unit.

## 4.2 Connection to a Non-JRC Exciter

You may prepare your own special control cable by using the 15-pin connector included with your JRL-2000F (cable and connectors for exciter end not supplied). Alternatively, you may purchase the optional CFQ-3889 Control Cable, which is 3m long and is equipped with the proper 15-pin connector for the JRL-2000F; you must supply all other connectors required for connection to your exciter.

### 4.2.1 Connection diagram

The following diagram illustrates the proper connection of control cable, antennas, and ground cable when the JRL-2000F is used with a non-JRC exciter.

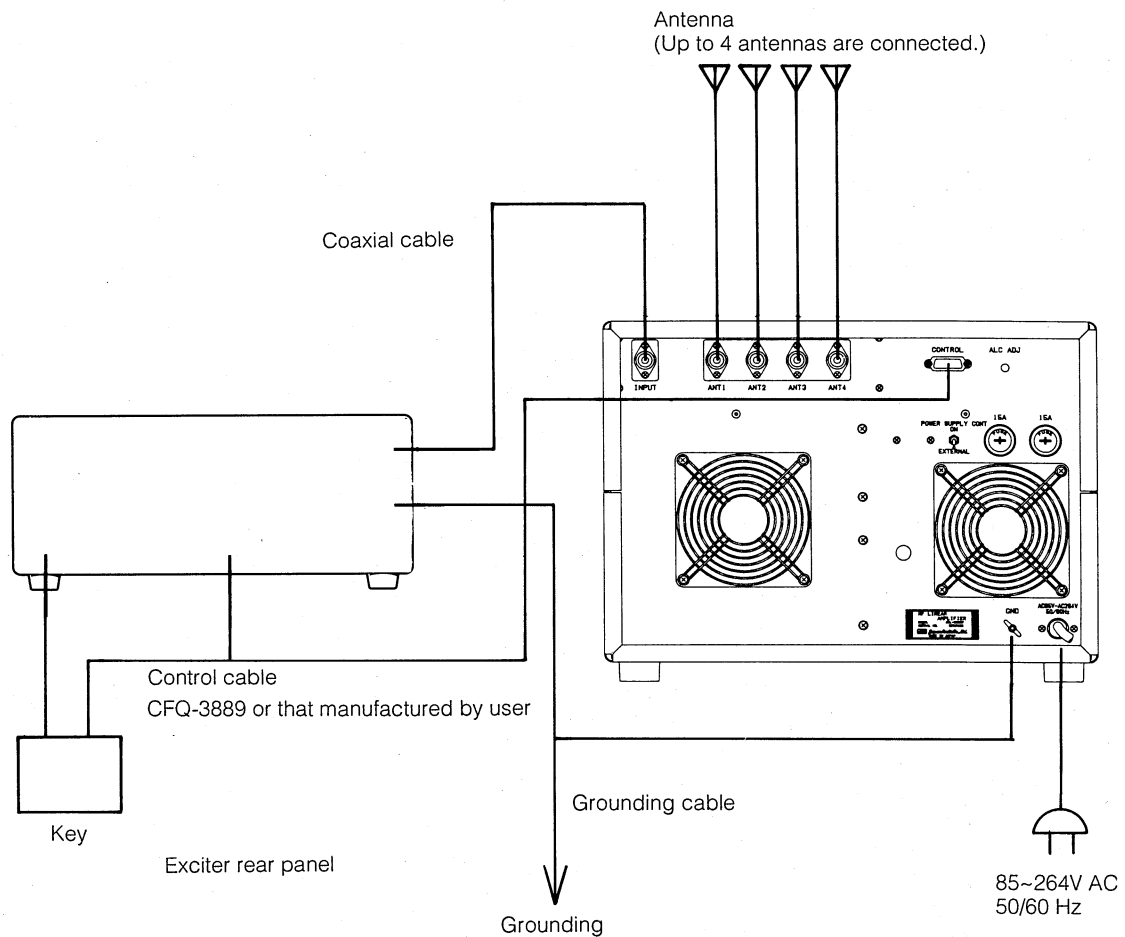

# 4 CONNECTION

## 4.2.2 Control cable wiring Diagram

The following shows the pin configuration of the JRL-2000F's 15-pin control connector.

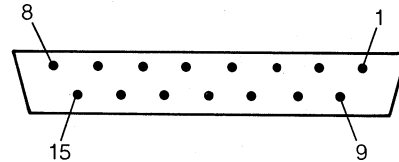

The pin numbers shown above correspond to the solder-side of the connector.

Pin number	Name	Description
1	E	Connect to the ground cable.
2	TXD	Do not connect (used only for the JST-135D).
3	RXD	Do not connect (used only for the JST-135D).
4	$\overline{\text{TX MUTE}}$	Do not connect (used only for the JST-135D).
5	ALC	Connect to the ALC terminal of the exciter; shielded wire should be used if possible. When the connection is completed, refer to "6.6 Adjusting the ALC Level".
6	$\overline{\text{RL}}$	When a linear amplifier is used and if there is an exciter terminal for the ground cable, then connect. If there is no ground terminal, do not connect.
7	E	Connect to the ground cable.
8	$\overline{\text{TX}}$	If a signal which becomes earth-grounding level at the time of transmission is output at the exciter terminal, connect. Refer to "Connection of KEY signal line" for details.
9	E	Connect to ground cable.
10	MIC MUTE	Do not connect (used only for the JST-135D).
11	$\overline{\text{SELBK}}$	If there is a terminal among the exciter terminals that is switched to transmission when connected to the ground cable, connect. Also, when applying CW, connect to the KEY. Refer to "Connection of forced transmission signal line" for details.
12	TX 13.8 V	If any signal that becomes 12 ~ 15V DC in transmission is output at the exciter terminal, connect. Refer to "Connection of KEY signal line" for details.
13	E	Connect to ground cable.
14	13.8 V	If a signal that is 12 ~ 15V DC, 0.1 A or more, and which is interlocked with the exciter ON/OFF is output, connect. Refer to "Connection of automatic power ON/OFF signal line" for details.
15	E	Connect to ground cable.

When constructing a custom control cable to connect the JRL-2000F to a non-JRC exciter, please follow the following wiring charts.

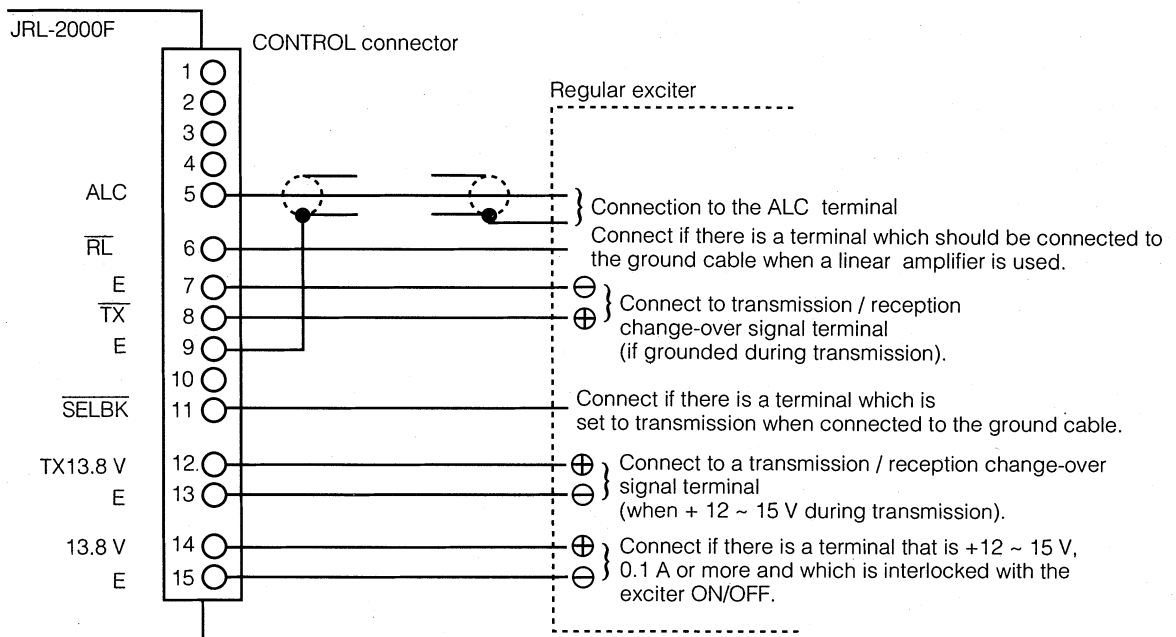

### Connection of KEY signal line (Pins 8 and 12)

A KEY signal places the linear amplifier into transmission mode when the exciter is switched from receive to transmit. Unless the KEY signal line is connected, the linear amplifier will not operate. The output method for the KEY signal, which indicates the exciter's transmit/receive status, differs between the various exciter models. The operation or technical manual for the exciter should be studied to determine which of the following methods is used:

- With many exciters the KEY signal becomes grounded during transmission. Connect this signal line to pin 8 (TX) of the JRL-2000F's control connector. There is a current of approximately 5 mA. When the exciter is in the receive mode, make sure no voltage exceeding 12 V is applied. If pin 8 is connected, do not connect any line to pin 12.
- If a signal of 12 to 15 V DC (H level) is output from the exciter during transmission, connect the line to pin 12 of the JRL-2000F's control connector. A current of approximately 5 mA is applied. If pin 12 is connected, do not connect any line to pin 8.

# 4 CONNECTION

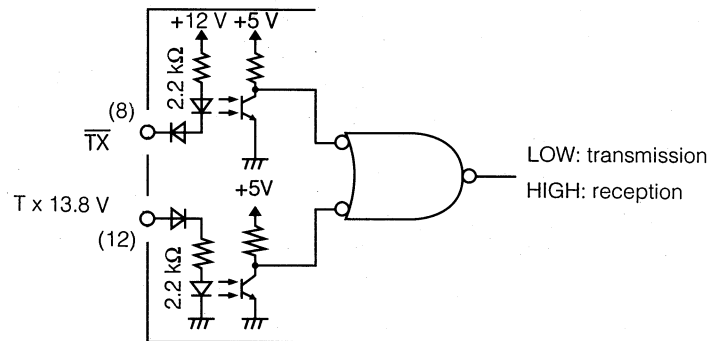

JRL-2000F Internal Circuit diagram (CDJ-1143)

**Important**

Note that automatic tuning will not be possible unless the KEY signal line from the exciter is connected.

**Connection of forced transmission signal line (Pin 11)**

When this signal line is connected, the exciter will automatically enter the transmission mode when the JRL-2000F is performing its automatic tuning and SET operations.

Basic operation is not affected if pin 11 is not connected. However, smooth operation is possible by connecting this pin. The forced transmission signal is at grounded level when the JRL-2000F issues a request for an RF signal. When there is no request, it is in the open state.

If there is a terminal on the exciter that switches the exciter to transmit when grounded, connect that terminal to pin 11. If not, connect pin 11 to the exciter's PTT terminal.

If CW is used, connect pin 11 to the exciter's KEY line as well unless negative voltage is applied to the KEY, for example in an exciter that uses vacuum tubes in the final stage. If negative voltage is applied, do not connect pin 11.

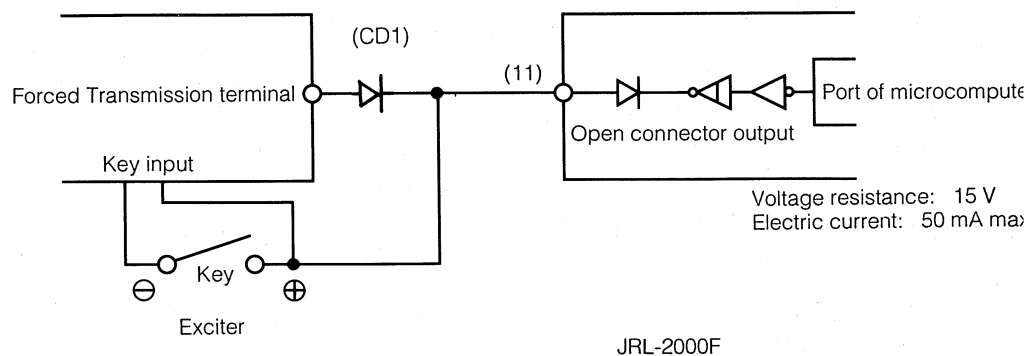

CD1: This may be required depending on the exciter. Usually, connect directly. (General Purpose Diode; IS1588, etc.)



**Important**

Verify that negative voltage is not applied when connecting the forced transmission signal line to KEY. Never connect pin 11 when there is negative voltage applied. Take special care if using an exciter with vacuum tube finals.

**Connection of automatic power supply ON/OFF signal line (Pin 14)**

The JRL-2000F power supply can be controlled by connecting 12–15 VDC (0.1 A max) to pin 14 of the JRL-2000F's control connector.

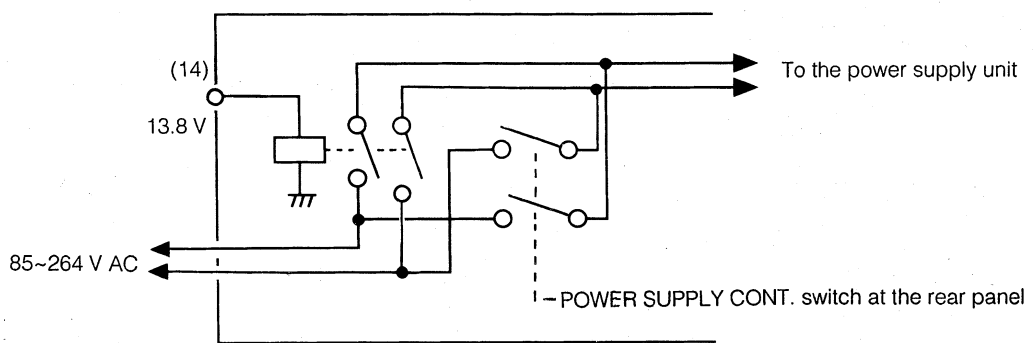

outer

/  
max.

# 5 OPERATING CONTROLS AND FUNCTIONS

## 5.1 Front Panel Controls

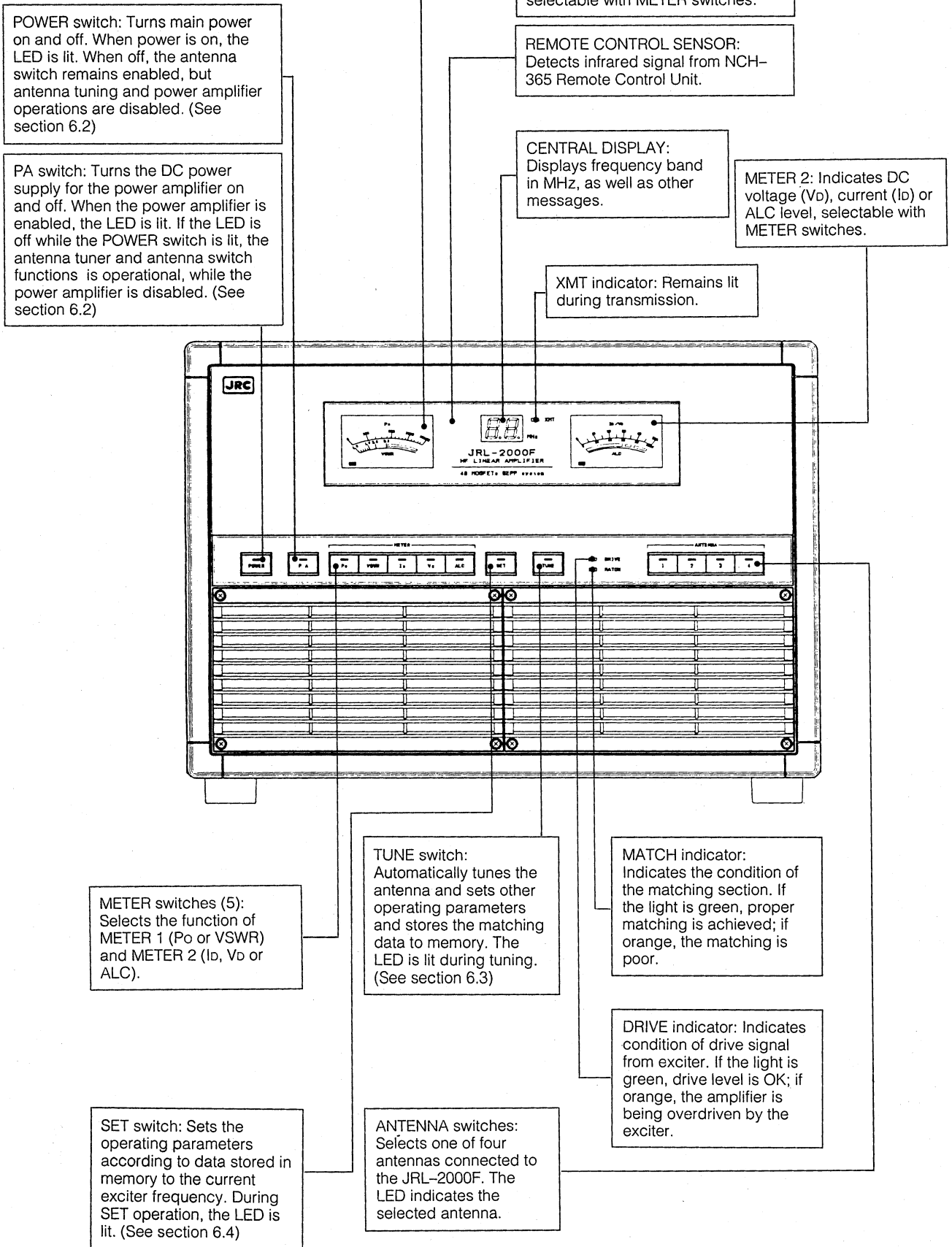

## 5.2 Rear Panel Controls

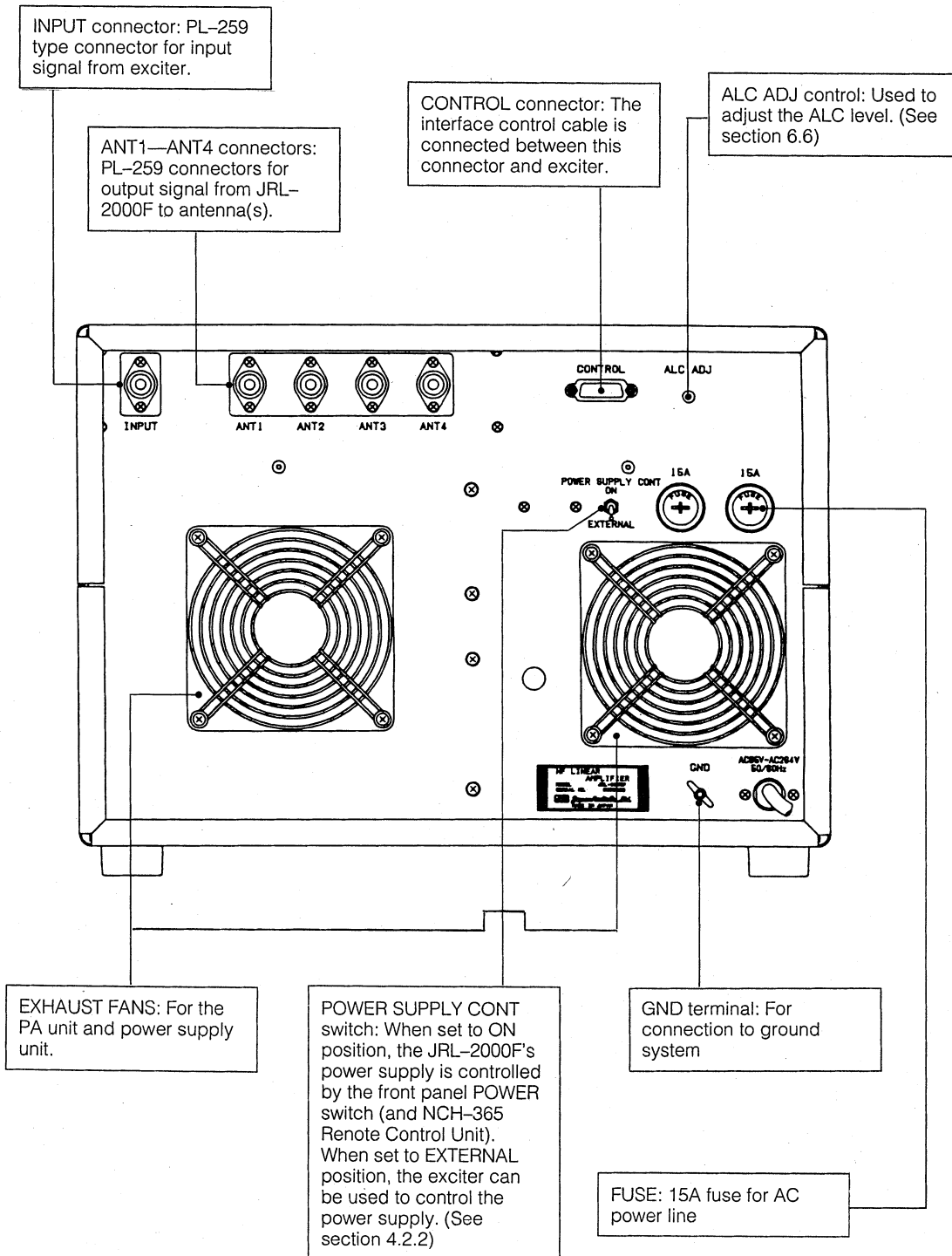

# 5 OPERATING CONTROLS AND FUNCTIONS

## 5.3 Remote Control Unit (NCH-365)

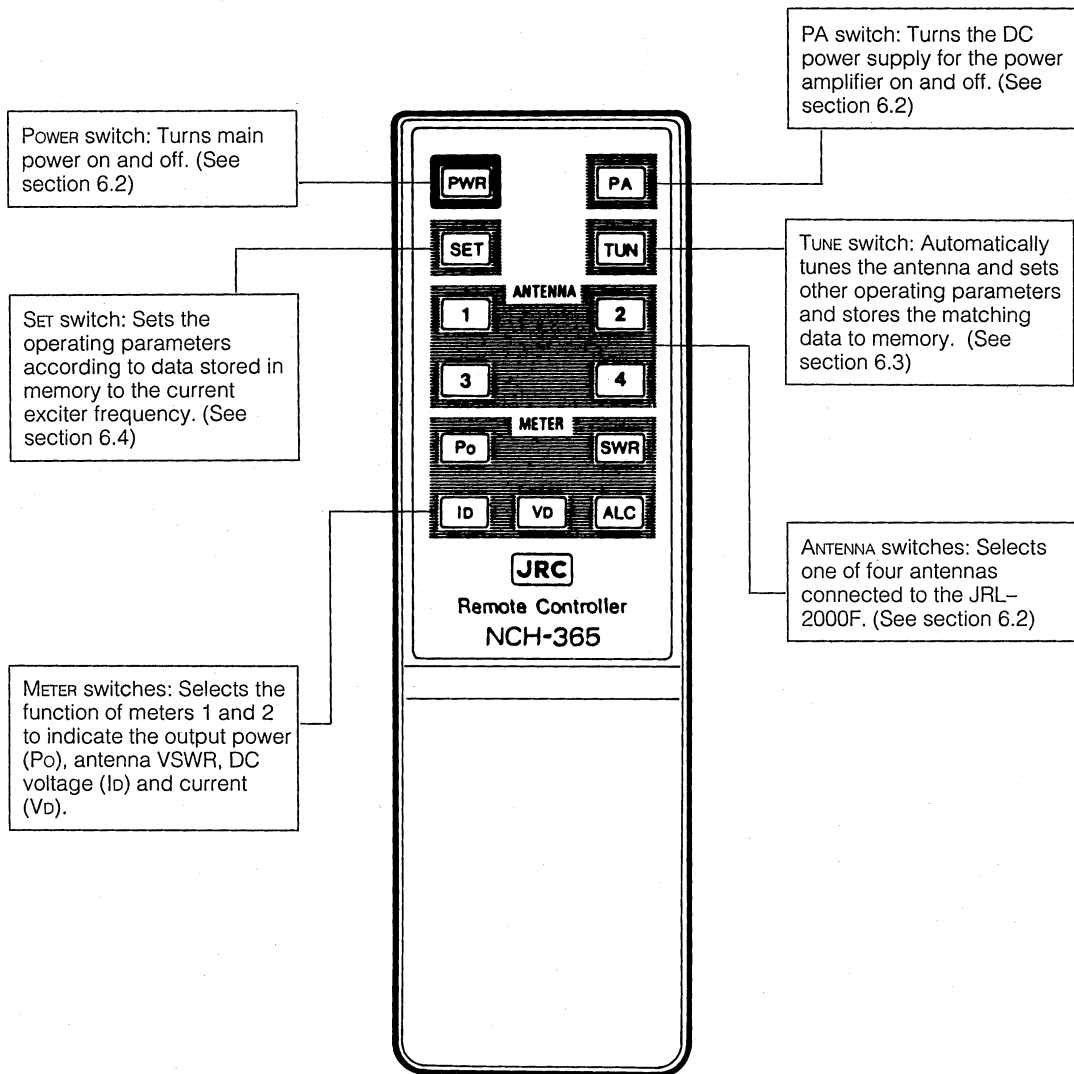

# 6 BASIC OPERATION

In this chapter, the basic operation procedures of the JRL-2000F Linear Amplifier are described.

## 6.1 Preparation

Before powering up your JRL-2000F for the first time, please verify each of the following items:

- Check all antenna connections.
- Check all connections to the exciter.
- Check all ground connections.
- Set the POWER SUPPLY CONT. switch on the rear panel to EXTERNAL.
- Turn off the power switch of the exciter .

## 6.2 Operation Modes

The JRL-2000F has three possible operating modes:

### Antenna Switch Mode

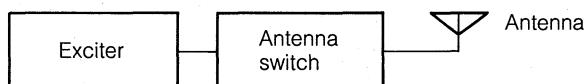

### Antenna Tuner Mode



### Linear Amplifier Mode

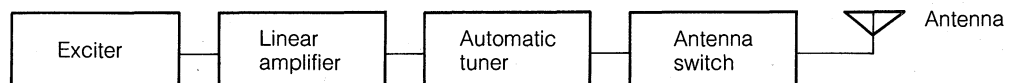

# 6 BASIC OPERATION

### **Important**

The JRL-2000F has two distinct two operating states: OPERATING and STOPPED.

- **OPERATING:** This applies to any of the operating modes described above (Antenna Switch Mode, Antenna Tuner Mode or Linear Amplifier Mode). While in the OPERATING state, the JRL-2000F can also be controlled by the supplied Remote Control Unit (NCH-365). Upon entering the OPERATING state, the JRL-2000F automatically returns to the last set of operating parameters that were used (antenna selection, tuner settings, etc.).
- **STOPPED:** When all power is cut off from the JRL-2000F, it is considered to be in the STOPPED state. All functions are inoperable, and RF output from the exciter is not supplied to the antenna. Also, control via the supplied Remote Control Unit (NCH-365) is not possible.

### 6.2.1 Operation of the POWER SUPPLY CONT. switch

The JRL-2000F power supply is controlled according to the setting of the POWER SUPPLY CONT. switch on the rear panel.

#### **When it is set to EXTERNAL**

The power supply is controlled according to the state of the voltage applied to pin 14 of the 15-pin control connector. See section 4.2.2 for connection details.

- When a voltage of 12~15 VDC is applied, the JRL-2000F is switched to the OPERATING state (power ON).
- If no DC power is applied to pin 14, the JRL-2000F will be in the STOPPED state.

#### **When it is set to ON**

The amplifier is continuously in the OPERATING state.

### 6.2.2 Antenna switch mode

The JRL-2000F operates as an antenna switch when it is in the OPERATING state and the **POWER** switch is set to the OFF position. The selected antenna (1, 2, 3 or 4) is indicated by the LED on the ANTENNA switch buttons.

Even if the **POWER** switch is set OFF, if the JRL-2000F is in the OPERATING state the unit can function as an antenna switch and operation can be performed with the Remote Control Unit (NCH-365)

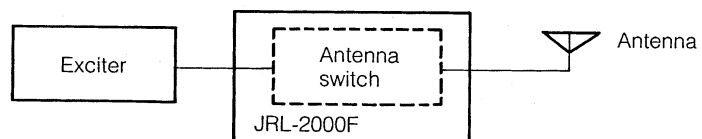

## 6.2.3 Antenna tuner mode

The JRL-2000F operates as an antenna tuner when it is in the OPERATING state, the **POWER** switch is set to the ON position and the **PA** switch is set to the OFF position. The two meters will be lit and their selected functions will be indicated by the LEDs on the METER switch buttons. The central display indicates the frequency band that the antenna tuner is currently tuned for.

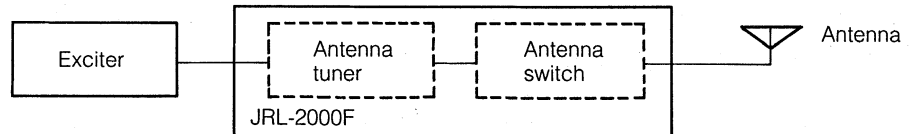

### **Important**

- When changing the frequency band, when the frequency is not indicated, or when the indicated frequency band is blinking, implement the automatic tuning or SET operation (see sections 6.3 and 6.4).
- During exciter transmission, be sure that the XMT LED is lit. If it is not, the KEY signal is not properly connected. In this case, please refer to section 4 and make sure all connections are correct.

## 6 BASIC OPERATION

### 6.2.4 Linear amplifier mode

The JRL-2000F operates as a linear amplifier when it is in the OPERATING state, and both the **POWER** and **PA** switches are set to the ON position. During exciter transmission, the XMT LED is lit. Also, an idling current of approximately 6A is supplied to the PA unit during transmission; during reception, the current is 0A.

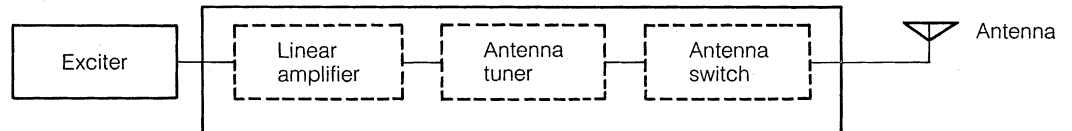

#### **Important**

- In some countries, including the United States of America, linear amplifier operation above 24 MHz is not possible.
- There is a time lag of approximately 0.6 seconds between the time the PA LED is lit and power is actually supplied to the power amplifier.
- The JRL-2000F can not be put into the Linear Amplifier Mode if:
  1. The operating frequency is not indicated in the central display; or,
  2. The frequency band indicated in the central display is blinking.In either case, implement the SET operation as described in section 6.4.
- The JRL-2000F can not be put into Linear Amplifier Mode while transmission is in progress.



## 6.3 Automatic Tuning Operation

During Automatic Tuning operation, the JRL-2000F matches the currently selected antenna to the frequency of transmission. The matching data and antenna selection is then stored into memory for instant recall at a later time.

There are two functions of the Automatic Tuner portion of the JRL-2000F:

- VSWR Matching — Matches the antenna VSWR and sets the load in the final stage of the exciter and linear amplifier to  $50\Omega$ .
- Low Pass Filter (LPF) — The LPF attenuates undesired harmonics contained in the output from the power amplifier.

After the tuning operation is completed, the data is stored in memory according to the JRL-2000F band assignments (see section 6.3.2). It is necessary to perform the automatic tuning operation for each band or sub-band.

For example, the 14 MHz band is divided into four sub-bands. Therefore, automatic tuning must be done within each of these sub-bands in order to cover the entire 14 MHz band.

Since antenna selection data is also stored, tuning must be done after selecting an antenna.

Tuning data remain stored in memory until:

- Automatic tuning within the same sub-band is performed again; or
- The data is deleted from memory (see section 7.1).

### ***Important***

Do not operate the JRL-2000F in any band or sub-band that has not been previously tuned. If excessive VSWR is present, one or more of the built-in protection circuits may be activated.

## 6 BASIC OPERATION

### 6.3.1 Automatic tuning procedures

The following instructions show how to implement the JRL-2000F's automatic tuning operation.

- ① Set the exciter as follows:
  - Select CW or FSK mode.
  - Set desired frequency.
  - Adjust output power of the exciter to 30 ~ 80 W.
- ② Select the desired antenna to be matched with the antenna switch. Verify that the selected antenna is capable of operation in the band to be tuned, and that it is connected properly.
- ③ Press the **TUNE** button. The **TUNE** LED will light and automatic tuning begins. If the forced transmission signal line (pin 11) of the control terminal is connected to the exciter, the exciter will automatically enter transmission mode. If pin 11 is not connected, see the "Supplements" section below.

The segment display rotates.

- Display during automatic tuning operation (segments rotating).

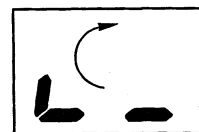

- ④ Upon completion of automatic tuning, the display will indicate as follows:

- Display indicating completion of automatic tuning operation



If **A7** is indicated or if the displayed frequency band is blinking, see the "Supplements" section below.

- ⑤ The frequency band is now shown in the central display, and matching data have been stored to memory for the current band or sub-band.

- Display indicating currently tuned frequency band (Example: 14 MHz)

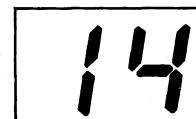

- ⑥ To verify that automatic tuning has been accomplished, set the **PA** switch to OFF and begin transmission with the exciter. Check that color of the MATCH LED is green. This indicates that the VSWR value is 1.5 or lower. If the color is orange, see the "Supplements" section below.

## Supplements

- **When the forced transmission signal line is not connected:**

Because the exciter will not automatically enter transmission mode, take the following steps to implement tuning:

1. Manually key the exciter to begin transmission. The JRL-2000F measures the operating frequency.
2. Stop transmission from the exciter.
3. Transmit again and remain in transmission mode until the automatic tuning operation is complete. Matching data will be written into memory for the selected band or sub-band.

- **When Po is indicated in the central display:**

This indicates that there is not sufficient input power to perform the automatic tuning operation. Adjust the power output control of the exciter to increase the drive level. The JRL-2000F can not perform automatic tuning unless there is more than approximately 20 W input.

- **When A7 is indicated in the central display:**

This indicates that automatic tuning has not been completed successfully. Check all antenna connections, antenna VSWR and exciter connections and try again.

- **When the color of the MATCH LED is orange:**

This indicates that antenna matching has not been completed successfully. Check all antenna connections, antenna VSWR and exciter connections and try again.

---

This completes the automatic tuning procedure. The JRL-2000F can be used in any band that has been tuned by the above operation. By implementing the automatic tuning operation in advance for all frequency bands and sub-bands that you plan to use, antenna switching and matching data can be quickly recalled for instant QSY.

### **Important**

- In some countries, including the United States of America, linear amplifier operation above 24 MHz is not possible. However, the JRL-2000F can be used as an antenna tuner in any band.
- The VSWR value of the antenna itself is displayed on the VSWR meter on the front panel. This reading will not change even after tuning has been completed. If the antenna VSWR is too high, it may cause radio interference.
- During automatic tuning the power amp is switched OFF even if the [PA] switch is set ON. After tuning, the [PA] switch will automatically return to its previous state.
- The antenna tuner is bypassed during receive operation.

# 6 OPERATION I (BASIC OPERATION)

## 6.3.2 JRL-2000F band assignment table

The JRL-2000F stores preset matching data in memory for each of the following bands and sub-bands:

Ham frequency band (MHz band)	Frequency (MHz) band	The JRL-2000F memory band assignment (MHz)	Antenna number			
			1	2	3	4
1.8	1.800~2.000	1.800~1.810				
		1.810~1.820				
		1.820~1.830				
		1.830~1.840				
		1.840~1.850				
		1.850~1.860				
		1.860~1.870				
		1.870~1.880				
		1.880~1.890				
		1.890~1.900				
		1.900~1.910				
		1.910~1.920				
		1.920~1.930				
		1.930~1.940				
		1.940~1.950				
		1.950~1.960				
		3.5	3.500~4.000	1.960~1.970		
1.970~1.980						
1.980~1.990						
1.990~2.000						
3.500~3.520						
3.520~3.540						
3.540~3.560						
3.560~3.580						
3.580~3.600						
3.600~3.620						
3.620~3.640						
3.640~3.660						
3.660~3.680						
3.680~3.700						
3.700~3.720						
3.720~3.740						
7	7.000~7.300			3.740~3.760		
		3.760~3.780				
		3.780~3.800				
		3.800~3.820				
		3.820~3.840				
		3.840~3.860				
		3.860~3.880				
10	10.100~10.150	3.880~3.900				
		3.900~3.920				
		3.920~3.940				
		3.940~3.950				
14	14.000~14.350	3.950~3.980				
		3.980~4.000				
		7.000~7.050				
18	18.068~18.168	7.050~7.100				
		7.100~7.150				
21	21.000~21.450	7.150~7.200				
		7.200~7.250				
		7.250~7.300				
24	24.890~24.990	10.080~10.150				
		14.000~14.080				
28	28.000~20.700	14.080~14.190				
		14.190~14.300				
		14.300~14.410				
		18.060~18.200				
		20.960~21.120				
		21.120~21.280				
		21.280~21.440				
		21.440~21.600				
		24.890~25.080				
27.930~28.140						
		28.140~28.160				
		28.160~28.380				
		28.380~28.600				
		28.600~28.820				
		28.820~29.040				
		29.040~29.260				
		29.260~29.480				
		29.480~29.700				

## 6.4 SET Operation

When one begins using the JRL-2000F or when the exciter frequency has been changed, the amplifier must be tuned by using the preset matching data which are stored in memory. This is done by pressing the SET switch on the front panel.

When the SET operation is performed, the JRL-2000F automatically measures the transmit frequency of the exciter and instantly sets the antenna tuner and selects the proper antenna according to the the preset data for the operating frequency.

During SET operation, the JRL-2000F acts as a dummy load so no interference is caused during tune-up.

Immediately after turning the power on, the JRL-2000F automatically recalls the settings from the previous operating session. Therefore it is not required to perform the SET operation if you are to operate on the same frequency as before.

If the Japan Radio Company JST-135 transceiver is used as the exciter, the SET operation is not required. The JRL-2000F will read the operating frequency from the JST-135 and set the matching data automatically.

### **Important**

If the power amplifier is operated without performing the SET operation and without matching the antenna, one of the JRL-2000F's protection circuits may be activated or undesired waves may be emitted.

### 6.4.1 SET operation procedures

After changing the transmitter frequency, press the **SET** switch. The LED on the **SET** switch will light and the preset matching data will be read from memory. If the forced transmission signal line (pin 11) of the JRL-2000F control terminal is connected to the exciter, the exciter will automatically enter transmission mode.

In CW mode, the JRL-2000F samples the RF signal from the exciter and reads the matching data from memory according to the transmit frequency of the exciter.

In SSB mode, it is necessary to speak a few words into the microphone in order to modulate the signal and allow the JRL-2000F to sample the transmit frequency.

If pin 11 is not connected, see the "Supplements" section below.

## 6 BASIC OPERATION

---

After performing the SET operation, the central display will indicate the frequency band that corresponds to the new settings. Always verify that the the exciter frequency matches the indicated band setting of the JRL-2000F, and that the proper antenna is selected. Also verify that the antenna VSWR matches the exciter's transmit frequency by turning the PA switch OFF and keying the exciter. The MATCH LED should light green, indicating a VSWR of 1.5:1 or lower. If the MATCH LED is orange or red, see the "Supplements" section below.

---

### Supplements

- **When the forced transmission signal line is not connected:**

Because the exciter will not automatically enter transmission mode, manually key the exciter to begin transmission. If the SSB mode is selected, speak a few words into the microphone. The JRL-2000F measures the operating frequency.

- **When PO is indicated in the central display:**

This indicates that there is not sufficient input power to perform the automatic tuning operation. Adjust the power output control of the exciter to increase the drive level. The JRL-2000F can not perform the SET operation unless there is more than approximately 30 W input.

- **When the color of the MATCH LED is orange or red:**

This indicates an error in the stored preset data and proper antenna matching has not been achieved. Please refer to section 6.3 and implement the automatic tuning operation.

---

**Important**

The preset data store the matching data for a single selected antenna output (one of four). Therefore, if a different antenna is used or if the antenna feedline is changed to a different antenna input on the amplifier, it is necessary to implement the automatic tuning operation once again after erasing the previous antenna preset data (see section 7.1).

## 6.5 Switching Antennas

When the exciter frequency has been automatically counted during the SET operation, the antenna output (1,2,3 or 4) that is stored with the preset matching data is selected. You can also select any of the other antennas by the antenna switch. The lit LED on the antenna switch button indicates the currently selected antenna output.

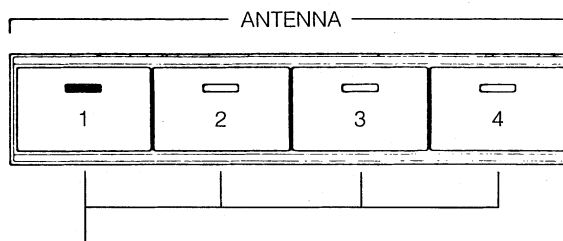

Press the switch with the antenna number you wish to select.

## 6 BASIC OPERATION

### 6.6 Adjusting the ALC Level

When the JRL-2000F is operating in the Linear Amplifier Mode (as described in section 6.2), always make sure that the ALC signal line is connected to the exciter's ALC terminal. The ALC level of the JRL-2000F can be adjusted by following the steps.

- ① Insert a regular screwdriver into the ALC ADJ adjustment hole on the rear panel of the JRL-2000F and turn the variable resistor fully clockwise (default factory setting).

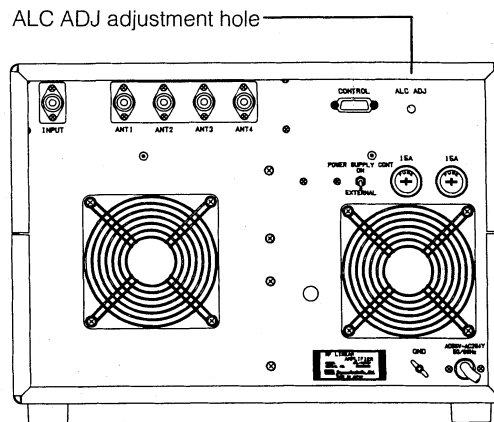

- ② Connect a 50 $\Omega$  dummy load or an antenna with low VSWR to the ANT1 connector.
- ③ Set the exciter to the desired frequency and set the transmission mode to CW or RTTY.
- ④ Turn the JRL-2000F power supply on (with the **POWER** switch on the front panel), select antenna number 1 (with the **ANTENNA** switch) and press the TUNE button. Refer to section 6.3 and implement the automatic tuning operation. The exciter's frequency band will be indicated in the amplifier's central display.
- ⑤ Press the **PO** and **ALC** buttons to change the meter functions accordingly.

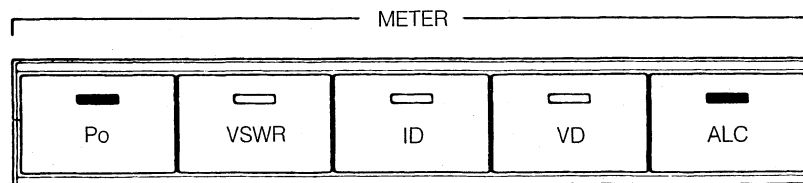



## BASIC OPERATION 6

- ⑥ Turn the exciter's power control to its lowest setting and set the exciter to the transmission mode.
- ⑦ Adjust the exciter's power control until the JRL-2000F's Po meter (left side) measures approximately 1050 watts. At this time, the pointer of the ALC meter (right side) should be a little beyond the white zone.

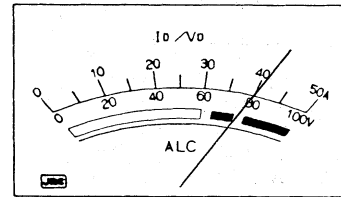
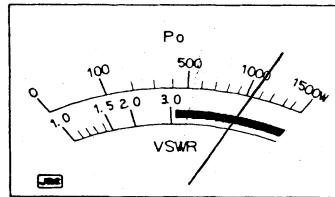

Meter indication

- ⑧ Turn the variable resistor for ALC level adjustment on the rear panel counterclockwise slowly, until the ALC meter's pointer is set inside the white zone. At this point, verify that the Po meter measures approximately 1000 watts.

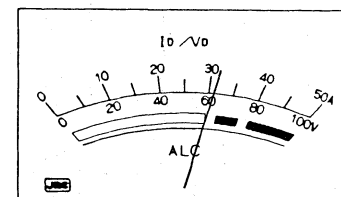
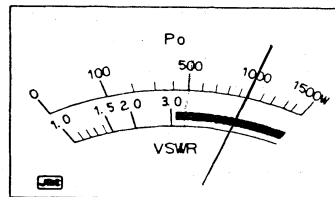

Meter indication

### **Important**

Depending on the exciter you are using, it may not be possible to keep the optimum ALC setting within the white zone on the ALC meter. However, if the Po meter does not exceed 1000 watts, then consider the ALC adjustment properly set.

- ⑨ Verify that the output power of the JRL-2000F does not exceed 1000 watts, even if the exciter output power is increased.
- ⑩ Return the exciter to standby or reception mode. The ALC adjustment procedure is now complete.

## 6 BASIC OPERATION

---

### 6.7 Memory Backup

Two types of memory are utilized in the JRL-2000F:

- Memory for preset data.
- Memory for maintaining the JRL-2000F's operating states.

#### **Memory for preset data**

The preset data written during automatic tuning operations are stored in EEPROM (ROM that can be electrically rewritten). The preset data are not erased when the JRL-2000F's power supply is turned off and the amplifier enters the STOPPED state.

#### **Memory for maintaining the JRL-2000F's operating states**

Data for maintaining the various operating states of the JRL-2000F ([POWER], [PA], meter settings, antenna switch settings, frequency band settings, etc.) are stored in RAM, which is backed up by a battery.

The backup state of the memory changes depending upon the DIP switch settings described in section 7.5.

The backup period for the RAM is approximately two weeks if the battery is fully charged. During this period, the previous operating state is recovered whenever the JRL-2000F is turned on. If the battery has been discharged, the contents of the RAM are lost and the some or all of the following default settings are recalled depending on the operating mode:

- [POWER]: Off
- Antenna switch: 1
- [PA]: off
- Meter selection: [PO] and [ID]

The above settings are the factory default settings. When the battery is discharged, it can be recharged by leaving the amplifier in the antenna switch mode or antenna tuner mode for about three hours or more.

## 6.8 Precautions

The JRL-2000F is equipped with a power amplifier with low IMD characteristics and high linearity, and a power supply unit with a high power margin. The amplifier is designed to generate and output signals of high quality and stability.

However, failure to use the JRL-2000F correctly may result in reduced performance such as poor sound quality or radio interference. Therefore, special attention should be paid to the following points during transmission:

### Frequency display

Always verify that the frequency band indicated in the amplifier's central display matches the exciter's transmission frequency.

### **MATCH** LED color

During transmission, the **MATCH** LED should be green in color. If the color is orange or red, proper antenna matching has not been achieved. In this case, you must implement the automatic tuning operation as described in section 6.3.

### **DRIVE** LED color

During transmission, the **DRIVE** LED should also be green in color. If it is orange in SSB mode, it indicates that the APC (Automatic Power Control) circuit inside the JRL-2000F has been activated due to over-excitation.

Even when the ALC level has been correctly adjusted, the amplifier's APC circuit may be activated if the power control or microphone gain on the exciter or the gain on the speech processor is too high. In this case, turn the power control or reduce mic gain until the DRIVE LED is lit green.

### Meters

The two meters should be checked regularly during transmission to verify that the JRL-2000F is operating normally.

- Check that the peak  $P_o$  value is not over 1000 watts.
- Check if the antenna VSWR is abnormally high.
- Check that the  $V_b$  voltage is set at about 80~85 V.
- Check that the  $I_b$  current is set at the correct value. When the continuous output power is 1000 watts, the  $I_b$  value should be approximately 22~27 A (input 1760~2160 W).

If the meter values are different from their normal readings, one of the causes may be a change in antenna impedance. In such cases, try matching again with the automatic tuning operation.

# 7 SPECIAL OPERATIONS

This chapter describes special operations of the JRL-2000F, which are not normally used during everyday operation..

## 7.1 Erasing Preset Data

The preset data stored during automatic tuning operations can be erased from memory by following the following procedures

### 7.1.1 Erasing all data for a selected antenna

All matching data for a specified antenna switch setting can be erased from memory. In other words, if antenna 1 is selected to execute erasing, all preset data stored for antenna 1 are erased. Data for other antennas remain unchanged.

#### To perform this operation:

- ① Turn the **POWER** switch off.
- ② Press the switch for the antenna whose preset data you wish to erase (1, 2, 3 or 4).
- ③ While holding down the selected antenna switch, press the **POWER** switch to turn the amplifier on. The antenna switch should be held down until the frequency indicated in the central display begins to blink.

### 7.1.2 Erasing all data for a selected frequency band

All matching data for a specified antenna in a single sub- band can be erased from memory. In other words, if antenna 1 is selected to execute erasing and the JRL-2000F is currently tuned to the first sub-band for 20 meters (14.000 to 14.080 MHz), all preset data stored for antenna 1 and that sub-band are erased. Data for other antennas and sub-bands remain unchanged.

#### To perform this operation:

- ① Turn the **POWER** switch on.
- ② Press the Po meter switch.
- ③ Press the switch of the antenna whose data you wish to erase (1, 2, 3 or 4).
- ④ Implement the **SET** operation at a frequency within the sub-band whose you wish to erase. Verify the frequency band indicated in the central display.
- ⑤ While holding down the antenna switch, press the **PO** switch. These two switches should be held down until the frequency band indicator in the central display begins to blink.

## 7.2 Write-protecting Preset Data

The preset data stored during automatic tuning operations can be protected against inadvertent erasure or changes by locking the **TUNE** switch. This makes it impossible to implement the automatic tuning operation.

**To perform this operation:**

- ① Turn off the **POWER** switch.
- ② While holding down the **TUNE** switch, turn the **POWER** switch on. The **TUNE** switch will now be locked

To undo this operation, simply repeat the above steps.

## 7.3 Using the JRL-2000F as a Dummy Load

The JRL-2000F can be used as a dummy load with an input resistance of 100 W. The operable frequency range is 1.8—30 MHz.

**To activate the dummy load setting:**

- ① Turn the **POWER** switch off.
- ② While holding down the **PA** switch, turn on the **POWER** switch. **PO** is blinked in the central display and the JRL-2000F functions as a dummy load for the exciter until the **POWER** switch is turned off. When turned on again, the JRL-2000F returns to normal operation.

# 7 SPECIAL OPERATIONS

## 7.4 Using More than 4 Antennas

The JRL-2000F can be operated with up to than 4 antennas connected directly to the amplifier. However, by utilizing common, commercially available antenna switches, the JRL-2000F can be used with stored matching data for more than 4 antennas. For example, by using three antenna switches, 8 antennas may be connected to the JRL-2000F as shown below.

The 8 antennas connected are:

Antenna A: For the 1.9 MHz band.

Antenna B: For the 3.5 MHz band.

Antenna C: For the 7 MHz band.

Antenna D: For the 10 MHz band.

Antenna E: Multi-band antenna for the 14 and 21 MHz bands.

Antenna F: For the 14 MHz band

Antenna G: Multi-band antenna for the 21 and 28 MHz bands.

Antenna H: Multi-band antenna for the 7, 21 and 28 MHz bands

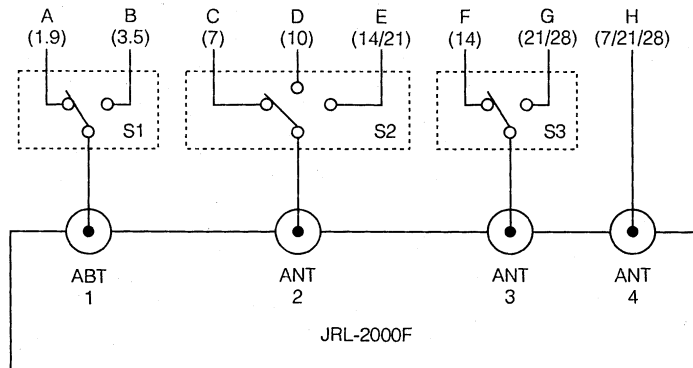

S1 ~ S3: Antenna change-over switches (50  $\Omega$  type)

### Memory address of preset data

When the antennas are connected as shown above, the matching data are stored as follows:

Frequency band	Antenna			
	1	2	3	4
1.9	A			
3.5	B			
7		C		H
10		D		
14		E	F	
21		E	G	H
28			G	H

A ~ H indicates memory blocks in which matching data are stored for respective antennas.

## 7.5 Setting the DIP Switches

The JRL-2000F has DIP switches for setting the memory backup state and for setting the overdrive alarm settings. These DIP switches are located on the CDJ-1143 CONTROL printed circuit board at the upper section of the main unit. It is visible when you remove the top cover of the JRL-2000F.

The functions of the DIP switches are described in the following table:

Switch number	State	Function
1	ON	Sets the RAM back-up state according to the states of DIP switches 2 and 3.
	OFF	Regardless of the states of DIP switches 2 and 3, the following functions are initialized when the device is shut down (the 13.8 V power from the exciter is turned off or the power cord is unplugged from the outlet). <ul style="list-style-type: none"> <li>· Frequency setting</li> <li>· <b>POWER</b> ON/OFF</li> <li>· States of the meters</li> <li>· The selected antenna</li> <li>· <b>PA</b> ON/OFF</li> </ul>
2	ON	Backs-up the frequency setting when DIP switch 1 is set to ON.
	OFF	Does not back-up the frequency setting.
3	ON	Backs up the ON/OFF states of the <b>POWER</b> and <b>PA</b> when DIP switch 1 is set to ON.
	OFF	Does not back up the ON/OFF states of the <b>POWER</b> and <b>PA</b> .
4	ON	Does not output the over-drive alarm when the <b>PA</b> is OFF (supports a 200 W output).
	OFF	Outputs the over-drive alarm when the <b>PA</b> is OFF.

Factory DIP switch settings are shown below

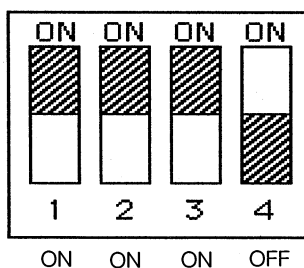

# 8 PROTECTION FUNCTIONS

## 8.1 Cooling Fans

The JRL-2000F is equipped with two cooling fans, which are activated under the following conditions:

The cooling fan in the power amplifier

This fan activates when the PA heat sink temperature exceeds approximately 50°C, and turns off after the temperature drops below approximately 40°C.

The cooling fan in the power supply unit

This fan activates when the power supply heat sink temperature exceeds approximately 45°C, and turns off after the temperature drops below approximately 40°C.

## 8.2 Causes of Alarms and Corrective Measures

The JRL-2000F is equipped with alarm circuits so that all internal electronic circuits can be protected from stresses and overloads caused by overdrive and abnormal output loads. If an alarm occurs, verify the cause and take the appropriate actions as described below.

When an alarm is activated, the alarm number is shown on the central display of the JRL-2000F. If the alarm number is lit steadily, the alarm state is currently in effect. If it is blinking, the alarm condition has occurred but is no longer in effect.

All alarms can be cancelled by turning the **POWER** switch off and on again.



## Alarm list

Display	Meaning	Cause and operational condition	Inspection and corrective measures
A1	Abnormality in power supply unit	The output voltage from the power supply unit has dropped while the [PA] is on. The cause is usually a sudden drop in the AC line voltage.	Check the power supply line (110 or 220V AC). Also, verify that the output is not excessive.
A2	Abnormality in power supply unit	Over-current (30 A or more) or over-heating (80°C or more) in the power supply unit.  Excessive voltage in the AC input line (270 V or more)	If the power amplifier current is excessive, decrease the exciter power.  Check the voltage in the power supply line. Check the ventilation.
A3	Overheated power amplifier	The power amplifier unit has been over heated. (80°C or more)	Verify that the output is not excessive, that the air filter is not clogged and that air is flowing normally.
A4	Unbalanced power amplifier	Output balance for the 4 power amplifier circuits is uneven.	If the fuse in the power amplifier section is blown, replace it with a new one. Verify that the idling current is approximately 6 A.
A5	Over-excitation	The excitation power from the exciter is excessive. (approximately 130 W)	Reduce the power from the exciter.
A6	Excessive tuning power	The power from the exciter is excessive during the automatic tuning operation. (80 W or more)	Reduce the power from the exciter Correct power is 30 ~ 80 W.
A7	Abnormal automatic tuning	Matching with the antenna has not been achieved during the automatic tuning operation.	Check the antenna connection and the VSWR value.
A8	Abnormality in the antenna	The antenna VSWR is too high.	Verify that the correct antenna is selected for the operating frequency, and that it is properly connected.
A9	Abnormal power amplifier load	The load seen from the power amplifier is abnormal.	Verify that the automatic antenna tuning operation has been correctly implemented and if necessary, perform the automatic tuning operation again. Also, verify the following : · That the antenna is normal. · That there is no abnormal output from the exciter (the linear amplifier output deviates resulting in oscillation).

# 9

# PRECAUTIONS ON MAINTENANCE AND OPERATION

## 9.1 Cleaning the Main Unit

The JRL-2000F has two internal ventilation fans. They draw in air from the front panel and expel it through the rear panel.

An air filter is mounted on the intake vent at the front panel so that dirt or dust will not enter the main unit.

Examine the condition of air filter behind the intake vent of the front panel and occasionally clean the air filter.

At the same time, clean the louvered area of the intake escutcheon, and the guard and propellers of the ventilation fans to remove any dust and dirt.

Close attention should be paid to the air filter because if it becomes clogged, the internal cooling performance declines, which may result in an alarm or machine failure.

The air filter should be removed in the following manner:

- ① Turn off the power supply to the JRL-2000F and unplug the power cord from the outlet.

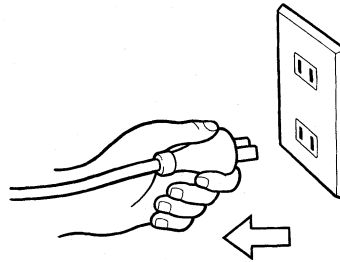

- ② Remove the screws from the intake vent and pull out the air filter.

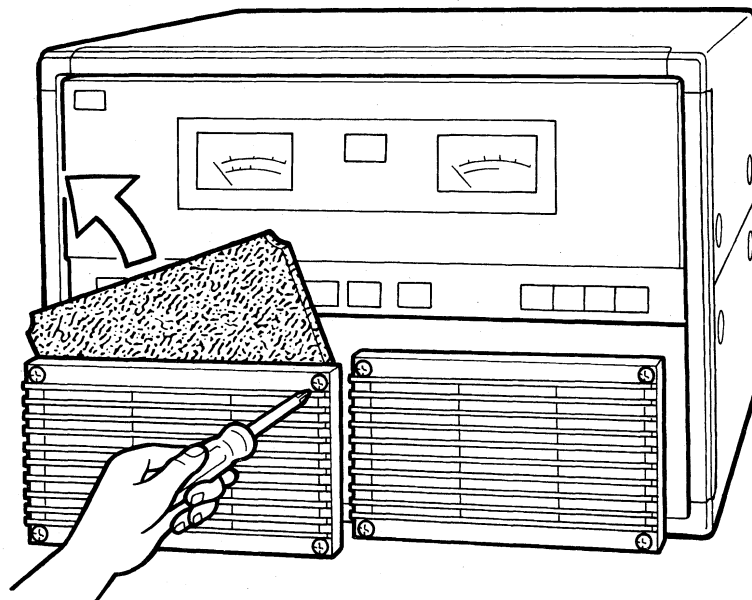

## 9.2 Maintenance of the Internal Circuits

It is not required to perform adjustment on the JRL-2000F internal circuits as they are completely preadjusted at the factory.

If, however, any problems occur during normal handling and operation, contact your dealer or your local JRC representative.

### **Attention**

JRC is not held responsible for any problems arising from intentional readjustment or modification of the internal circuits by the user.

## 9.3 Radio Interference Precautions

Ham radio transmitters may, under certain circumstances, cause interference to domestic television sets, radios, stereos etc. Of course, such problems are usually not entirely attributable to the ham radio station.

JRC, as a manufacturer, conducts very thorough adjustment and inspection in an attempt to prevent undesired or spurious radiation. If, however, radio interference does occur during operation, stop transmitting immediately. Special care should be taken in regard to the following and appropriate measures should be taken.

- If it has been ascertained that a ham station is causing interference to television and radio reception by its radio waves, you should stop transmitting immediately to verify the presence or absence of interference and the degree of interference.
- If it has been ascertained that the interference has been caused by your ham station, inspect the transmitter and antenna system and take appropriate measures according to the degree of interference.

## 9.4 Precautions Against Power Surge Caused by Lightning

When there is electrical storm activity in the area, lightning surge pulse may be induced in the antenna. In such a case, the radio may be struck by a surge of very high voltage. In order to minimize damage by lightning coming in via the antenna, the JRL-2000F is equipped with a high-speed arrestor. Nevertheless, relays in the output circuit, tuner circuit, the final-stage amplifier etc, may be damaged due to their highly precise and delicate circuit configurations.

Therefore, the user is advised to stop operation immediately and turn off the power supply when an electrical storm threatens.

# 10 PROBLEM SOLVING

## 10.1 After-sales Service

When the JRL-2000F does not operate properly, refer to "10.2 Troubleshooting" to make sure that it really has a problem.

If it should become obvious that the JRL-2000F does have a problem, immediately unplug the power supply cord from the outlet and contact your dealer or the JRC Customer Service Department.

See the back page of the warranty for regulations on warranty coverage.

## 10.2 Troubleshooting

Before you jump to the conclusion that the machine has a problem, check the following items.

Symptom	Cause	Cure	Reference
No power-up ① The antenna switch cannot be operated independently. ② The POWER cannot be turned on from the front panel.	The 13.8 V power from the exciter is not supplied or the POWER SUPPLY CONT. switch on the rear panel is set to EXTERNAL. The exciter is in the transmission mode.	Check the connections or set the POWER SUPPLY CONT. switch on the rear panel to ON. Turn the POWER on after setting the exciter in the reception mode.	6.2.1 (P. 18)
The [PA] cannot be turned on.	① Automatic tuning has not been achieved (the frequency display is off or blinking). ② The exciter frequency is not within the ham frequency band. ③ The frequency is in the 28 MHz frequency band. ④ The exciter is in the transmission mode.	Implement the automatic tuning operation. Or switch to the antenna in which the automatic tuning operation has been successfully achieved. Reset the exciter frequency within the Ham frequency band. The [PA] cannot be turned on in the 28 MHz frequency band. Turn the [PA] on after setting the exciter to reception mode.	6.3 (P. 21)
The automatic tuning operation and / or the SET operation cannot be implemented.	① Insufficient output power from the exciter ② The control cable is disconnected. ③ The coaxial cable is not connected correctly, or the cable has poor contact.	Increase the output power from the exciter. Connect the control cable securely. Make correct connection.	6.3 (P. 21) 4.
Low output power	① The ALC level setting is not correct. ② The output power from the exciter is insufficient. ③ An alarm is in effect. ④ The [PA] is off.	Readjust the ALC level. Increase the output power from the exciter. Turn the POWER on again after turning the JRL-2000F off. Turn the [PA] on.	6.6 (P. 28) 6.2.4 (P. 20)
The frequency does not change correctly during the SET operation.	The exciter is in the split mode.	During the SET operation, the exciter transmission frequency is counted.	6.4 (P. 25)
The automatic tuning operation is aborted while in progress.	① The output power from the exciter is insufficient. ② Relay is not switched in the transmission mode.	Increase the output power from the exciter. In the automatic tuning operation, the frequency is counted first, and then tuning is implemented. When the operation shifts from frequency counting to tuning, set the exciter to the reception mode first.	6.3 (P. 21)
When entering the operating state upon start-up, there is nothing displayed on the central indicator.	The battery that backs up the RAM has been discharged.	Charge the battery for a minimum of three hours.	6.7 (P. 30)

# 11 OPTIONS

In order to use the JRL-2000F most effectively, the following control cables are available:

## Control cable for the JST-135D (CFQ-3890)

This is a cable exclusively used for connecting the JRL-2000F and the JST-135D. It is 3 m long and has a connector at each end.

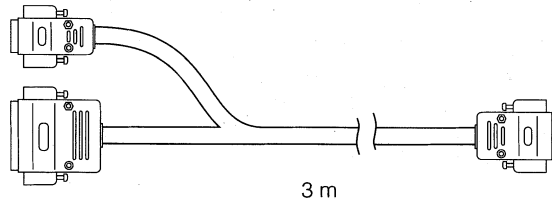

## General-purpose control cable (CFQ-3889)

This is a control cable for a regular exciter and is 3 m long. It has a connector for the JRL-2000F at one end and the other end is free to accept a suitable connector for the exciter you are using.

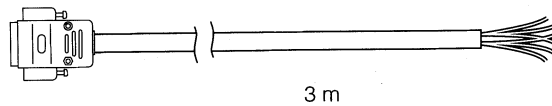

Pin number	Color of Wire	Name	Description
1	Shield Wire	E	⊙
2	Brown	TXD	×
3	Blue	RXD	×
4	Gray	TX MUTE	×
5	White	ALC	⊙
6	Red	RL	△
7	Orange	E	△
8	Yellow	TX	*
9	Shield Wire	E	⊙
10	Green	MIC MUTE	×
11	Black	SELBK	△
12	Bright Green	TX13.8V	*
13	Pink	E	△
14	Sky Blue	13.8V	△
15	Shield Wire	E	⊙

⊙ This must be always connected.

\* Either end must be connected.

△ Connection may be required, or connection may be convenient.

× Exclusively for JST-135D. Usually, connection is not required.

# 12 ATTACHED DIAGRAMS

---

## 12.1 External View

## 12.2 Block Diagram

## 12.3 Connection Diagrams

JRL-2000F	Overall connection diagram
NAH-232	Power amplifier unit connection diagram
CCB-367	Power amplifier control connection diagram
CAH-377	Power amplifier connection diagram
CFF-361	Power combiner connection diagram
NBL-169	Power supply unit connection diagram
CBG-68	Main power supply connection diagram
CBB-13	Power factor corrector connection diagram
CFR-102	Noise filter connection diagram
CFG-111	Matching circuit connection diagram
CSC-433	Antenna switch connection diagram
CDJ-1143	Control connection diagram
CML-334	Display connection diagram
CSD-387	Switch panel connection diagram
CSA-222	Relay circuit connection diagram

# 12-1 External View

Front Panel

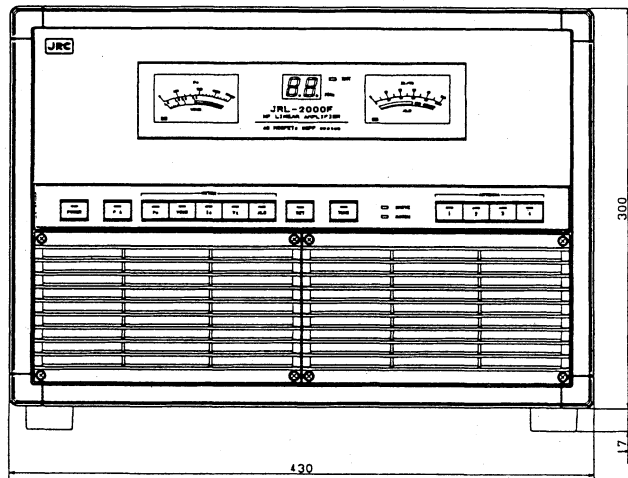

Side Panel

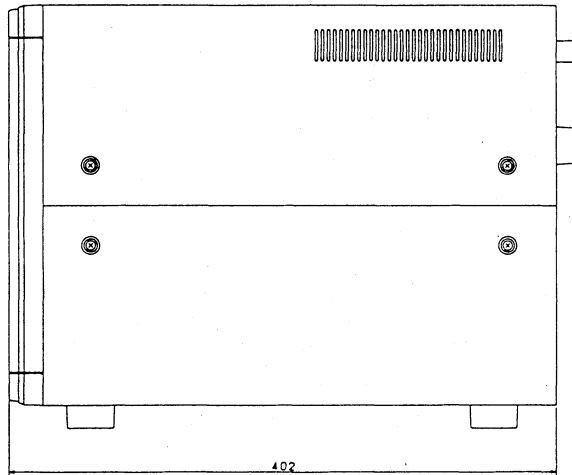

Rear Panel

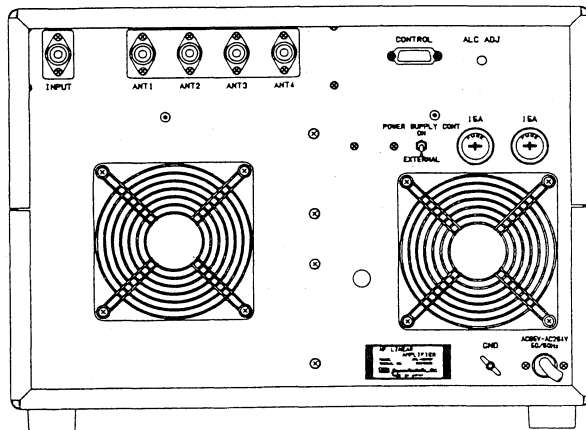

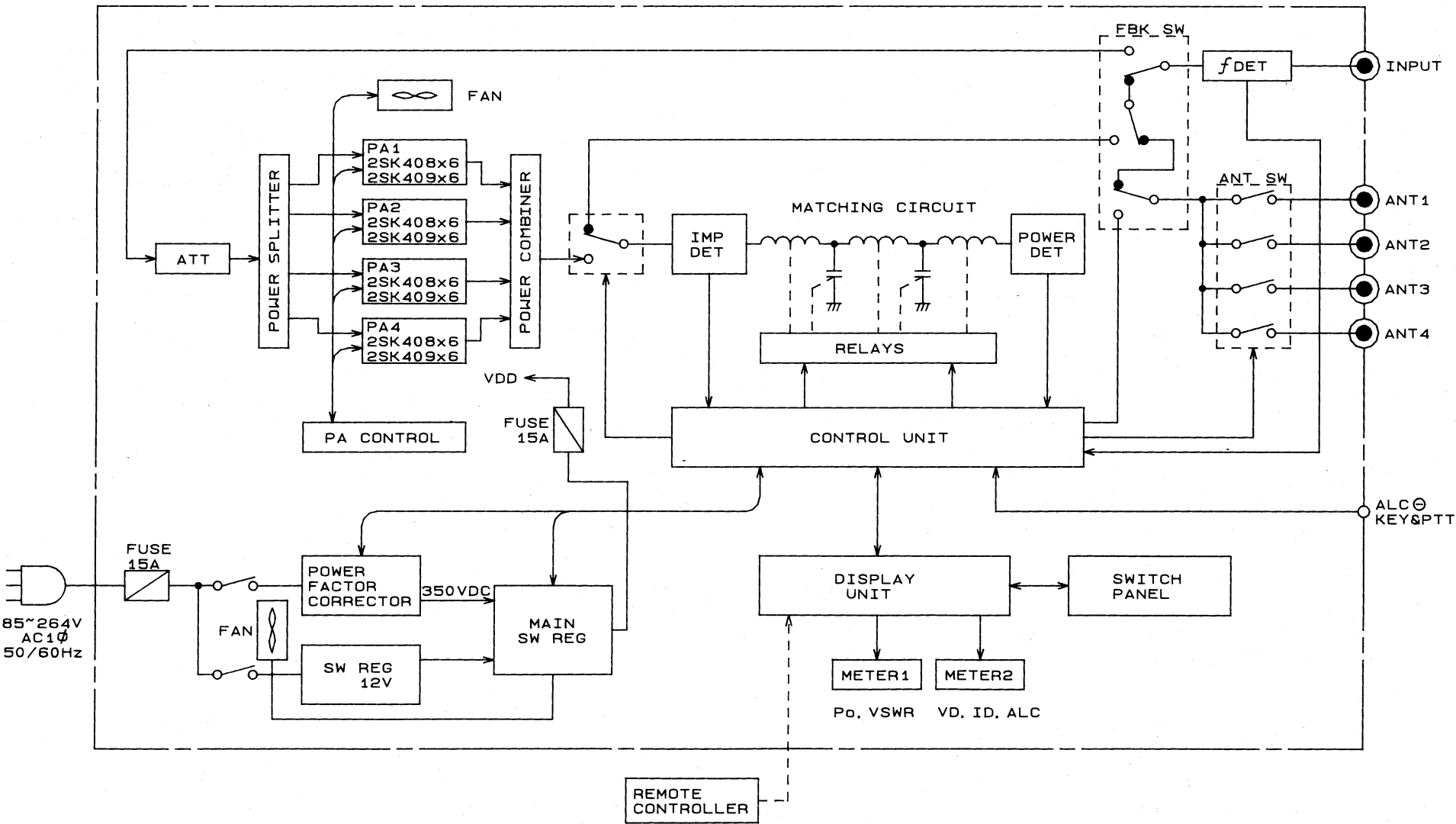

12-2 JRL-2000F HF LINEAR AMPLIFIER  
BLOCK DIAGRAM



12-3 JRL-2000F HF LINEAR AMPLIFIER  
INTERCONNECTION DIAGRAM

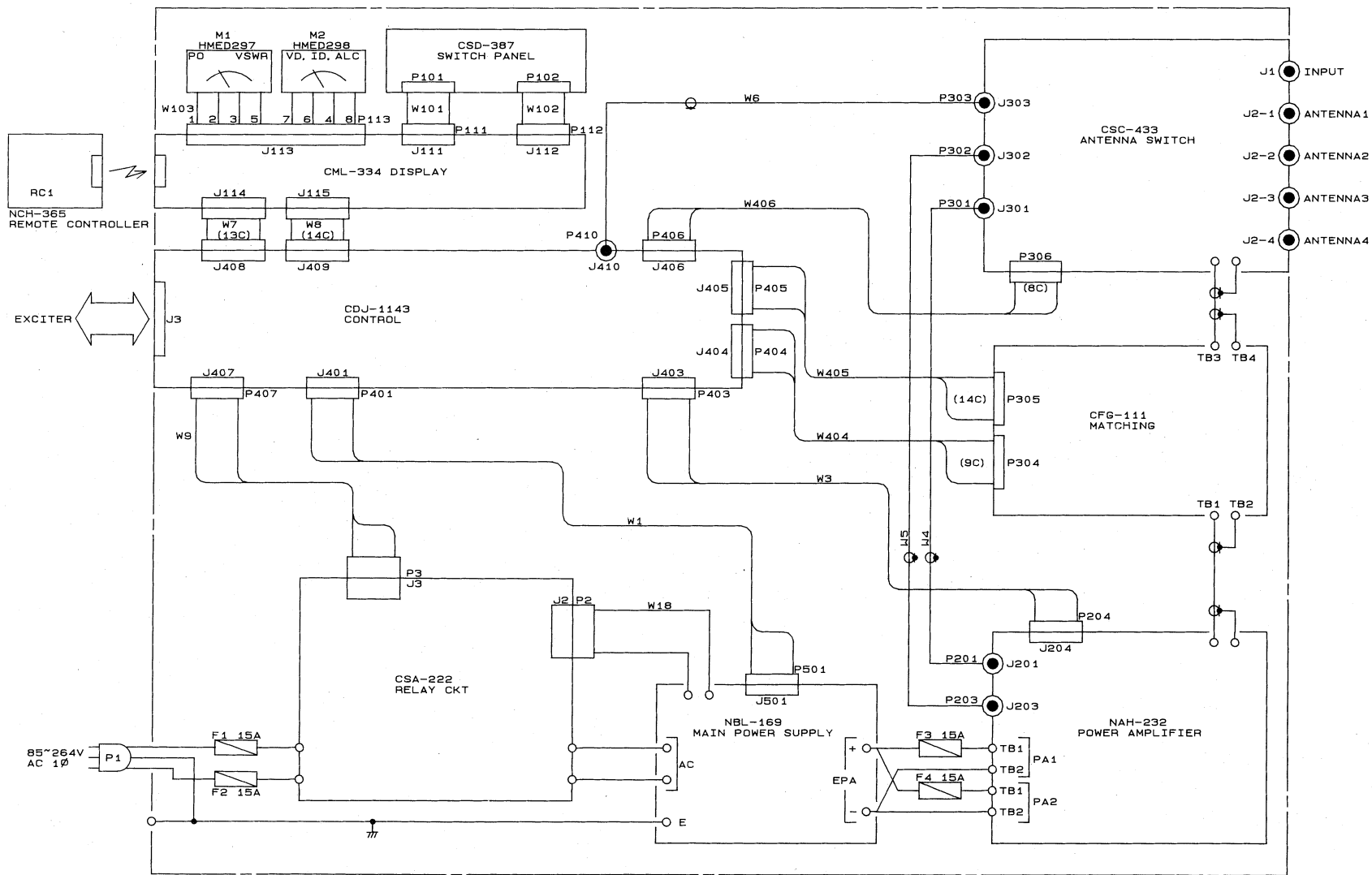

# 12-3 NAH-232 POWER AMPLIFIER

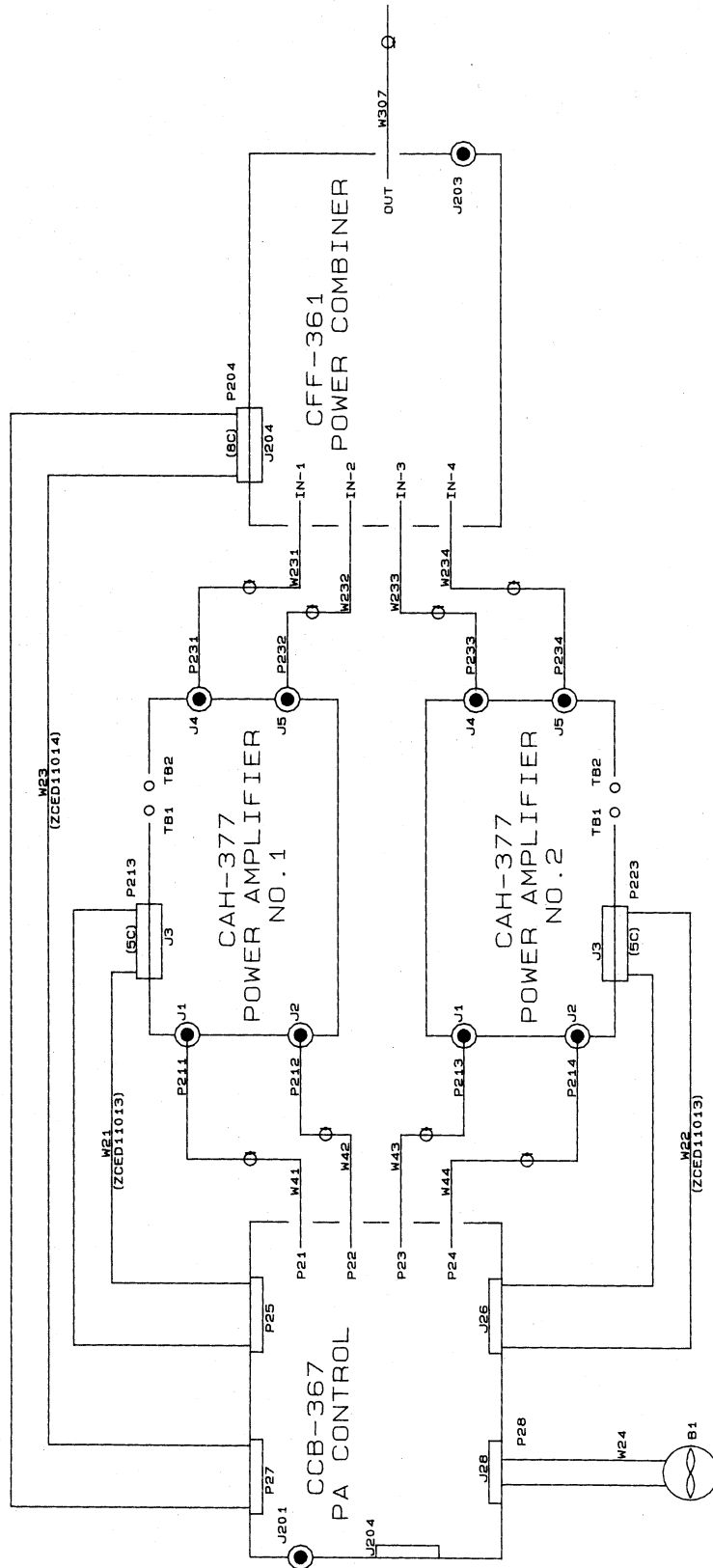

W41~W44 : 1. 5D-2V (ZCED310)  
 W231~W234 : 2. 5D-2V (ZCED311)  
 W307 : 5D-2V

12-3 CCB-367 PA CONTROL

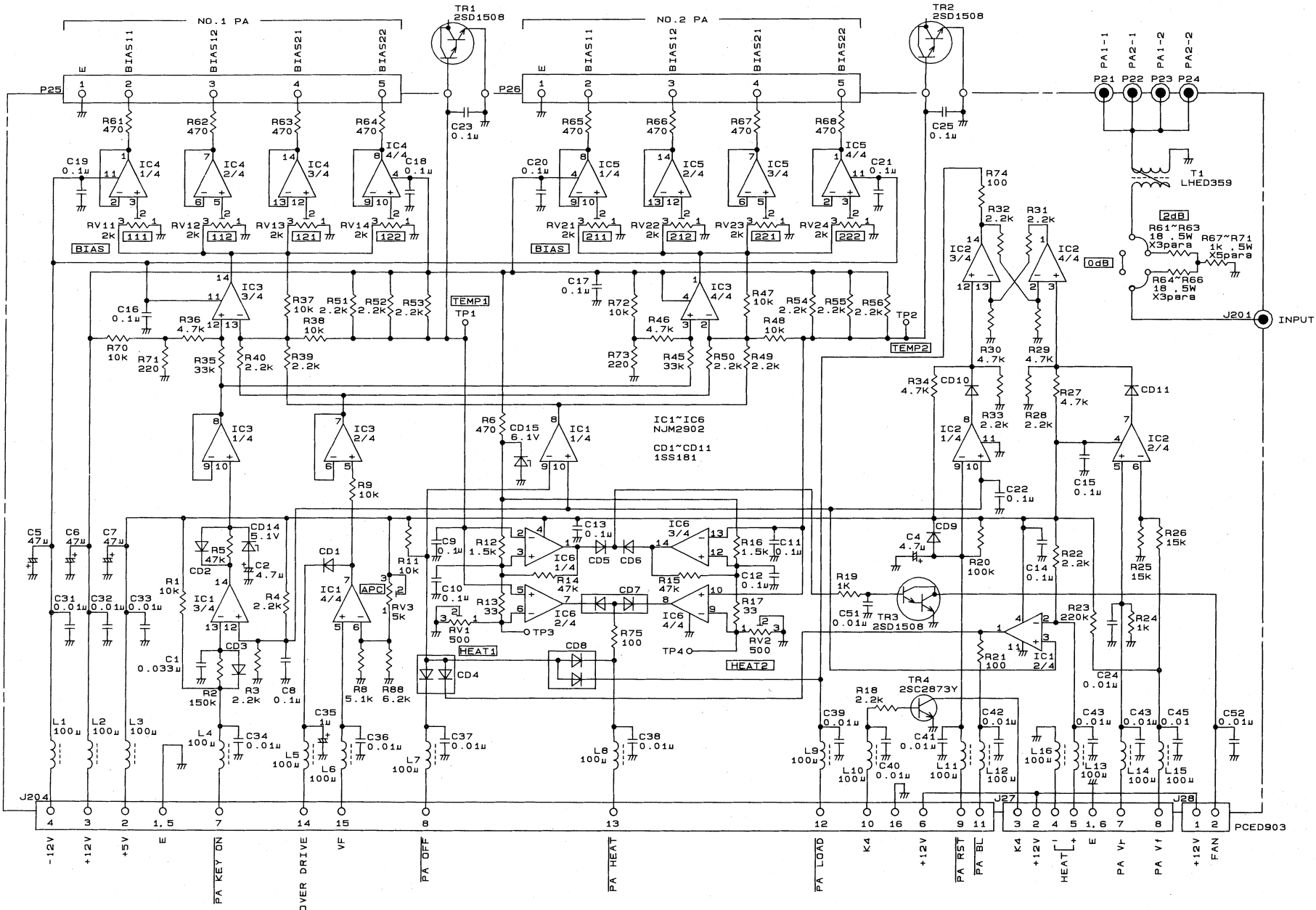

12-3 CAH-377 POWER AMPLIFIER

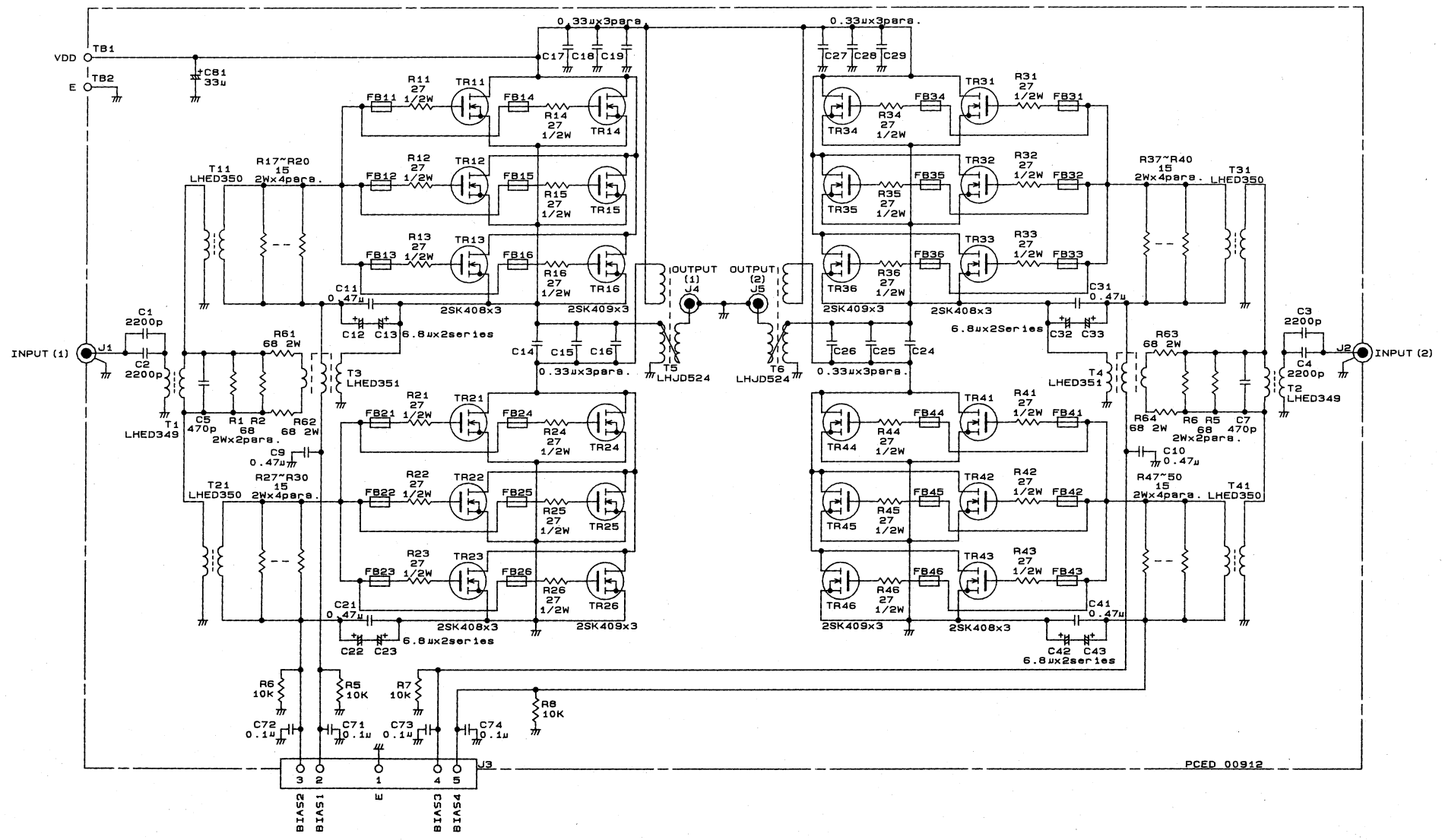

12-3 CFF-361 POWER COMBINER

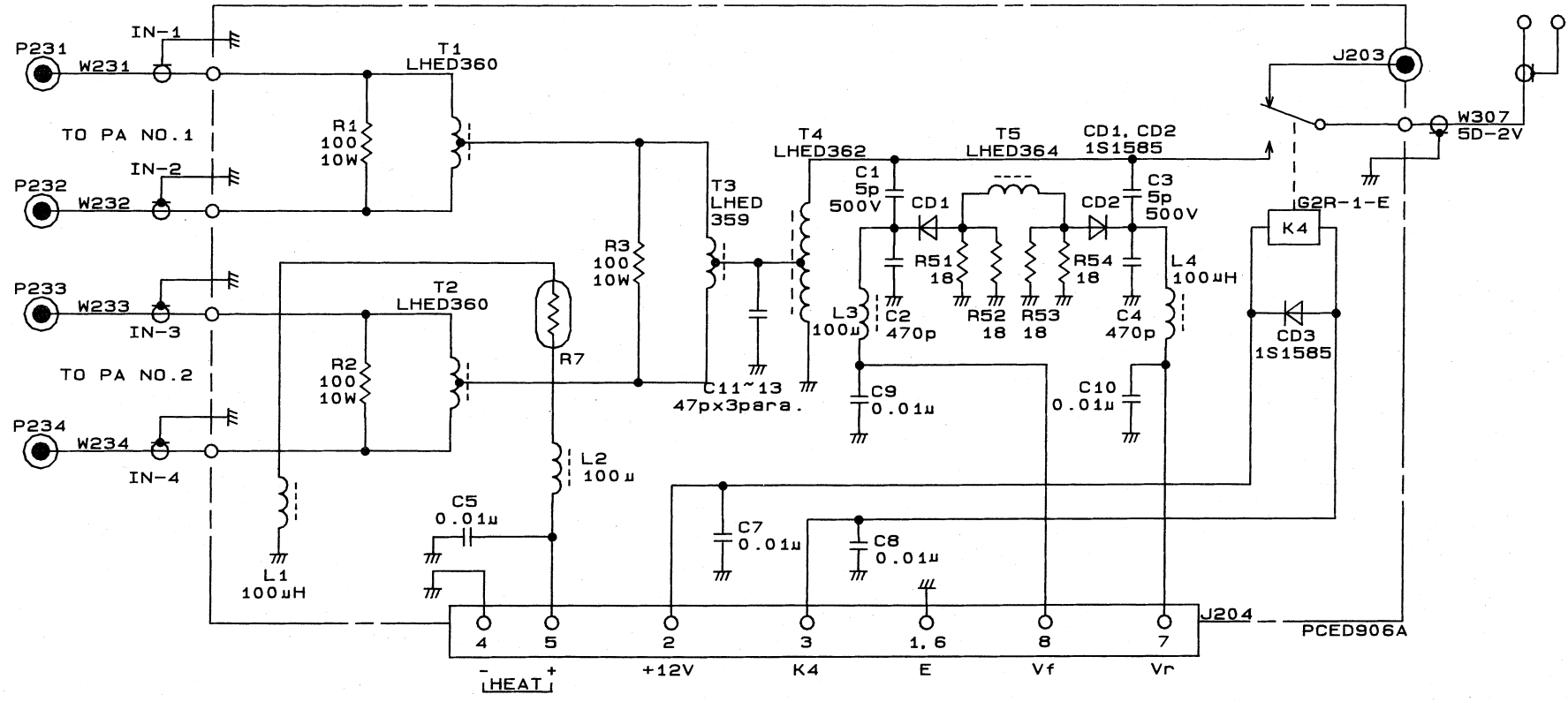

# 12-3 NBL-169 POWER SUPPLY UNIT

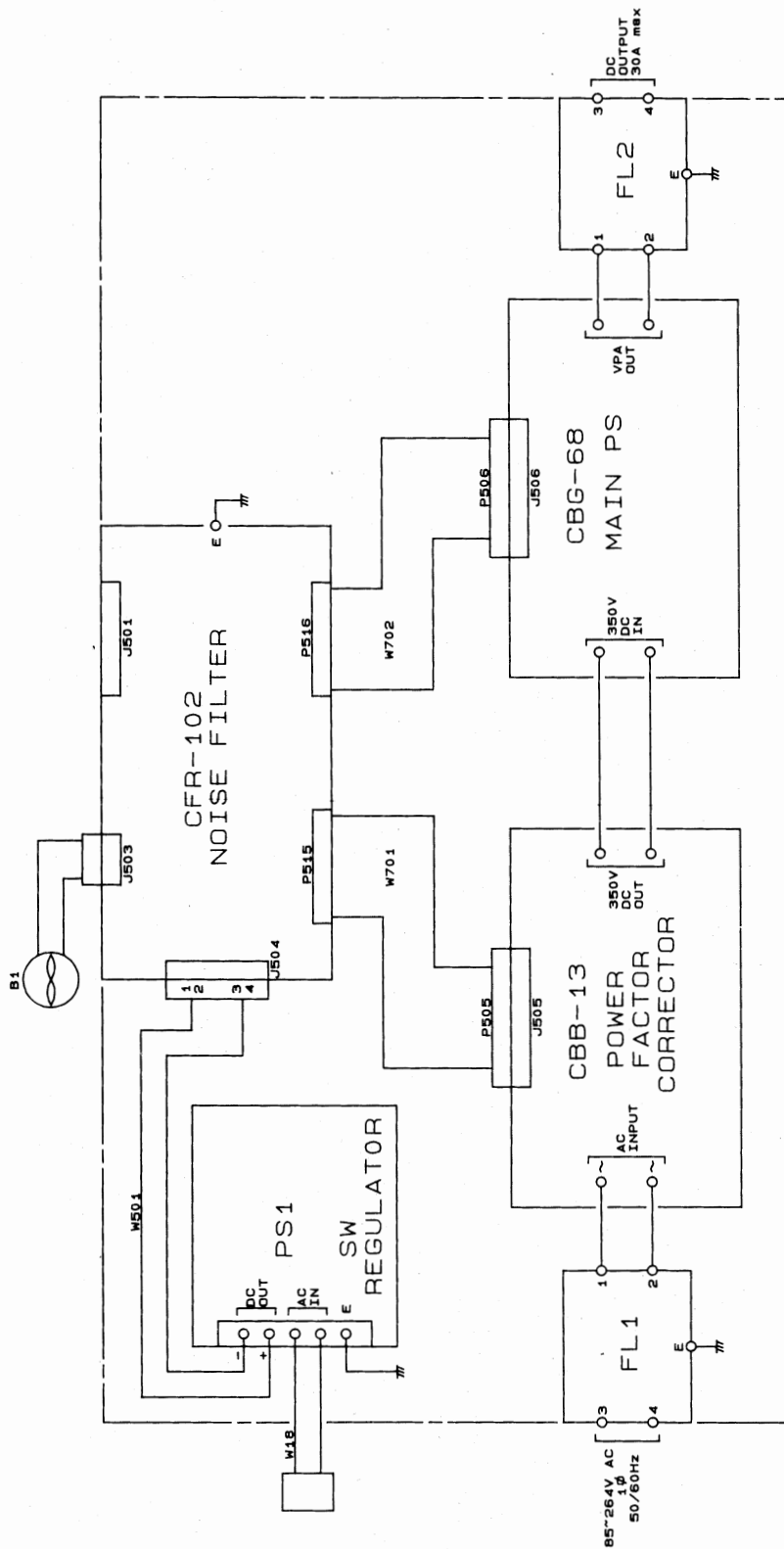

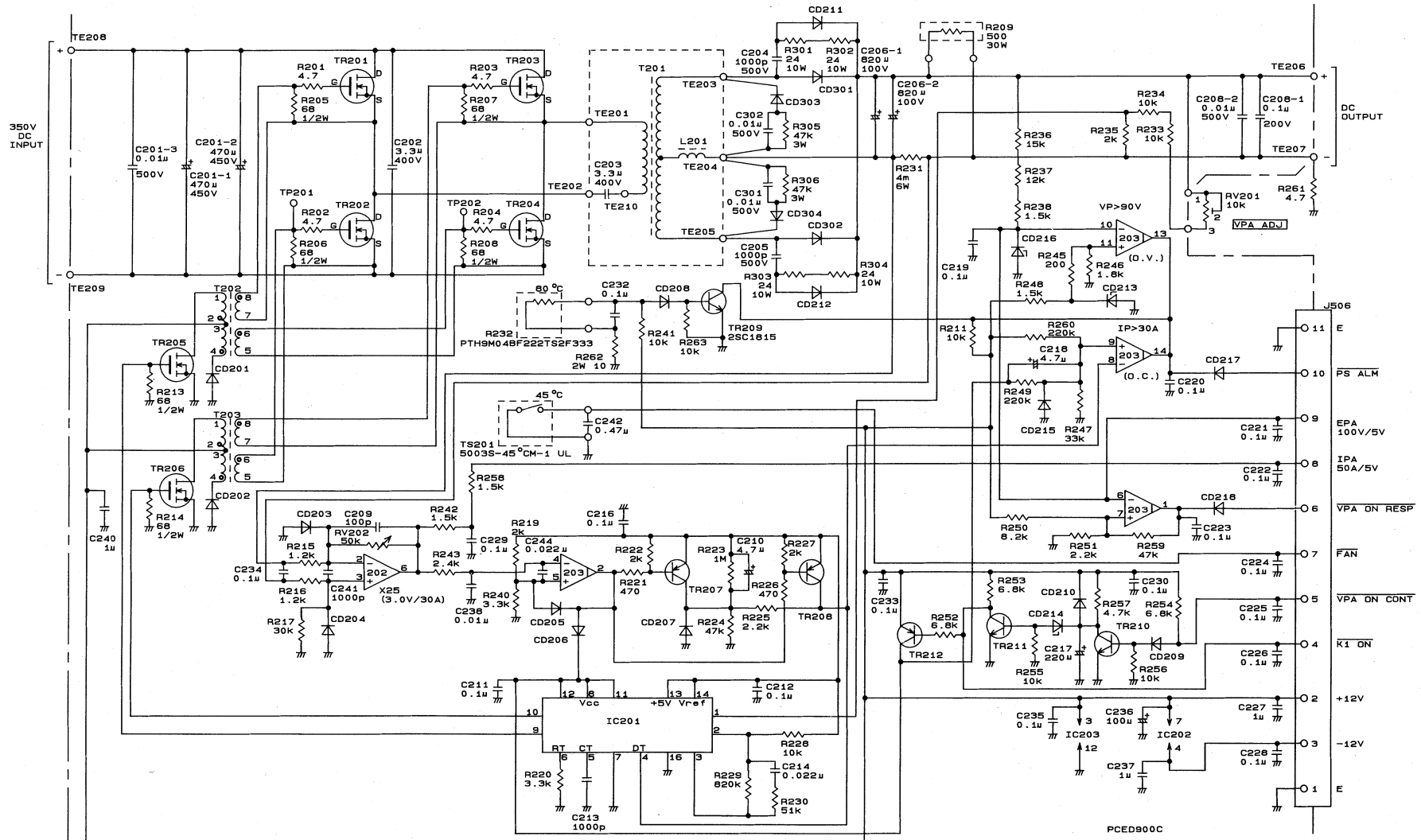

TR201~204	2SK1250	IC201	TL594CN	CD211, 212	R64C
TR205, 206	IRFU120	IC202	OP-07DP	CD213, 214, 216	HZ5C1
TR207, 208, 212	2SA1020	IC203	NUM2901N	CD301, 302	30KF50B
TR209, 210	2SC1815	CD201, 202	H114B	CD303, 304	R64C
TR211	2SC2655	CD203~210, 215, 217, 218	1S1588		

12.3 CBG-68 MAIN PS UNIT





# 12-3 CFR-102 NOISE FILTER

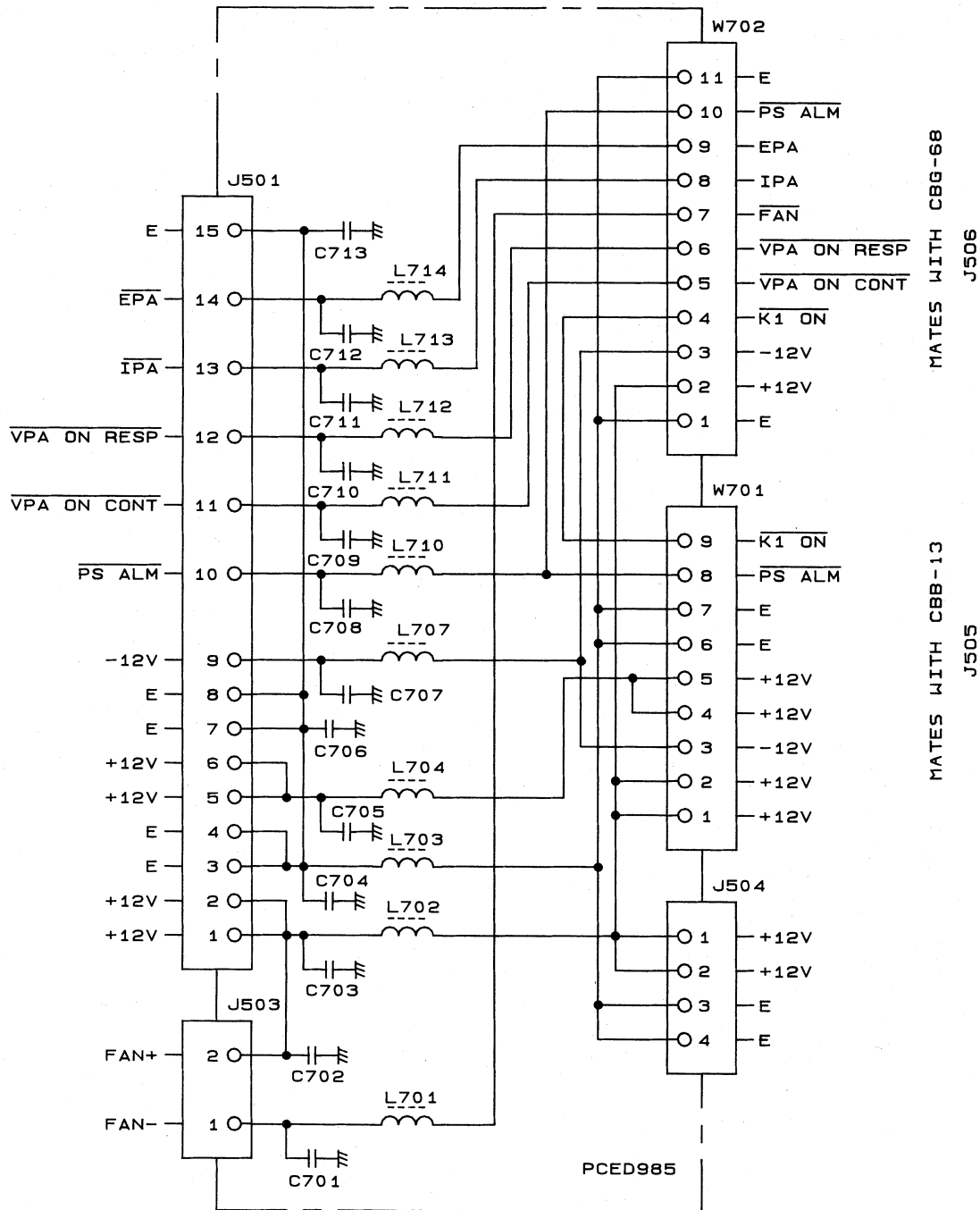

C701~714: 50V 0.1uF (RPE 132F104Z50)  
 L701~704: 72uH (SF-T8-50S)  
 L707~711: 100uH (LF85-101K)  
 L712~714: 100uH (LAL04NA101K)

MATES WITH CBG-68 J506  
 MATES WITH CBB-13 J505

12-3 CFG-111 MATCHING CKT (1/3)

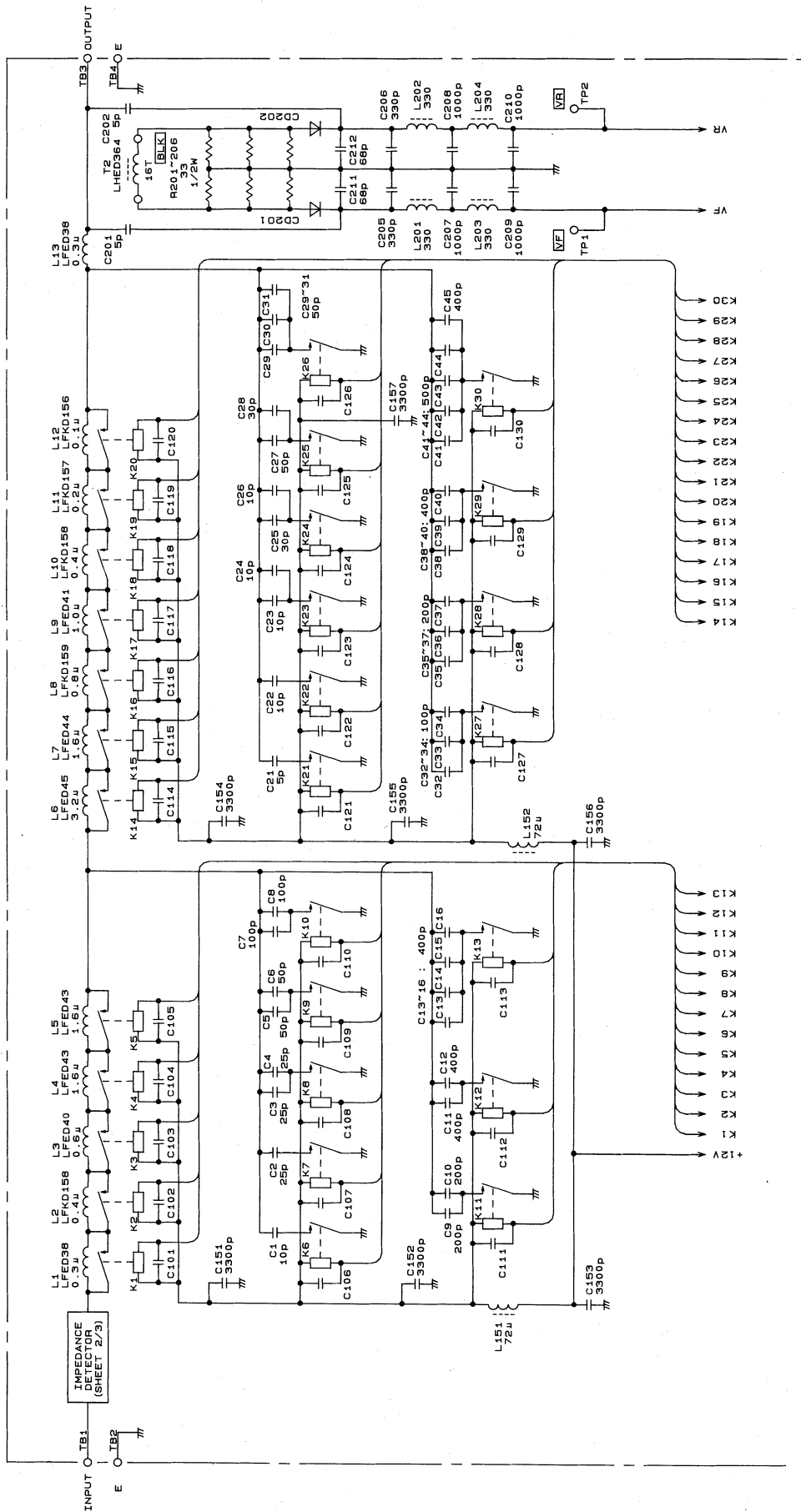

PCED854

# 12-3 CFG-111 MATCHING CKT (2/3)

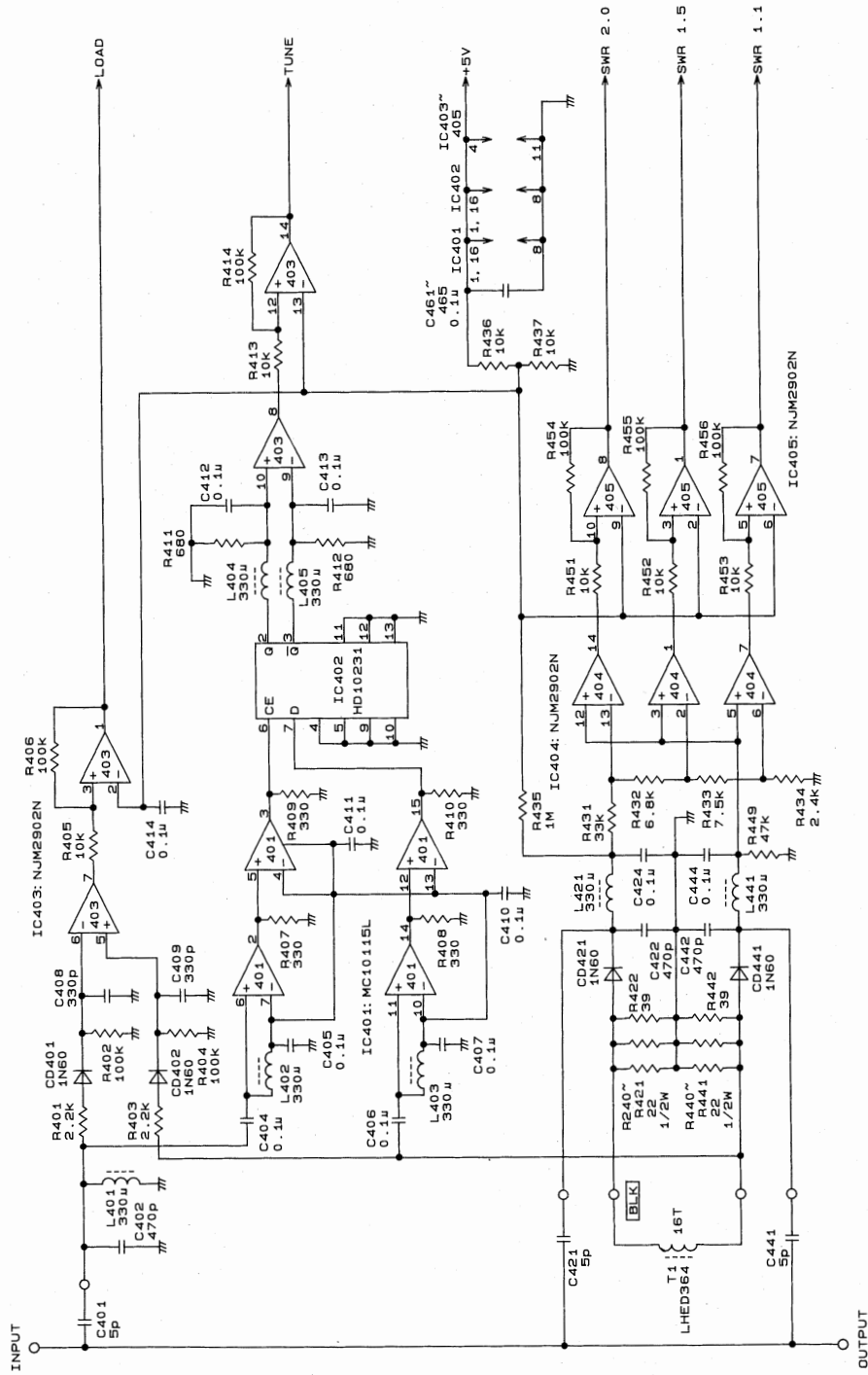

# 12-3 CFG-111 MATCHING CKT (3/3)

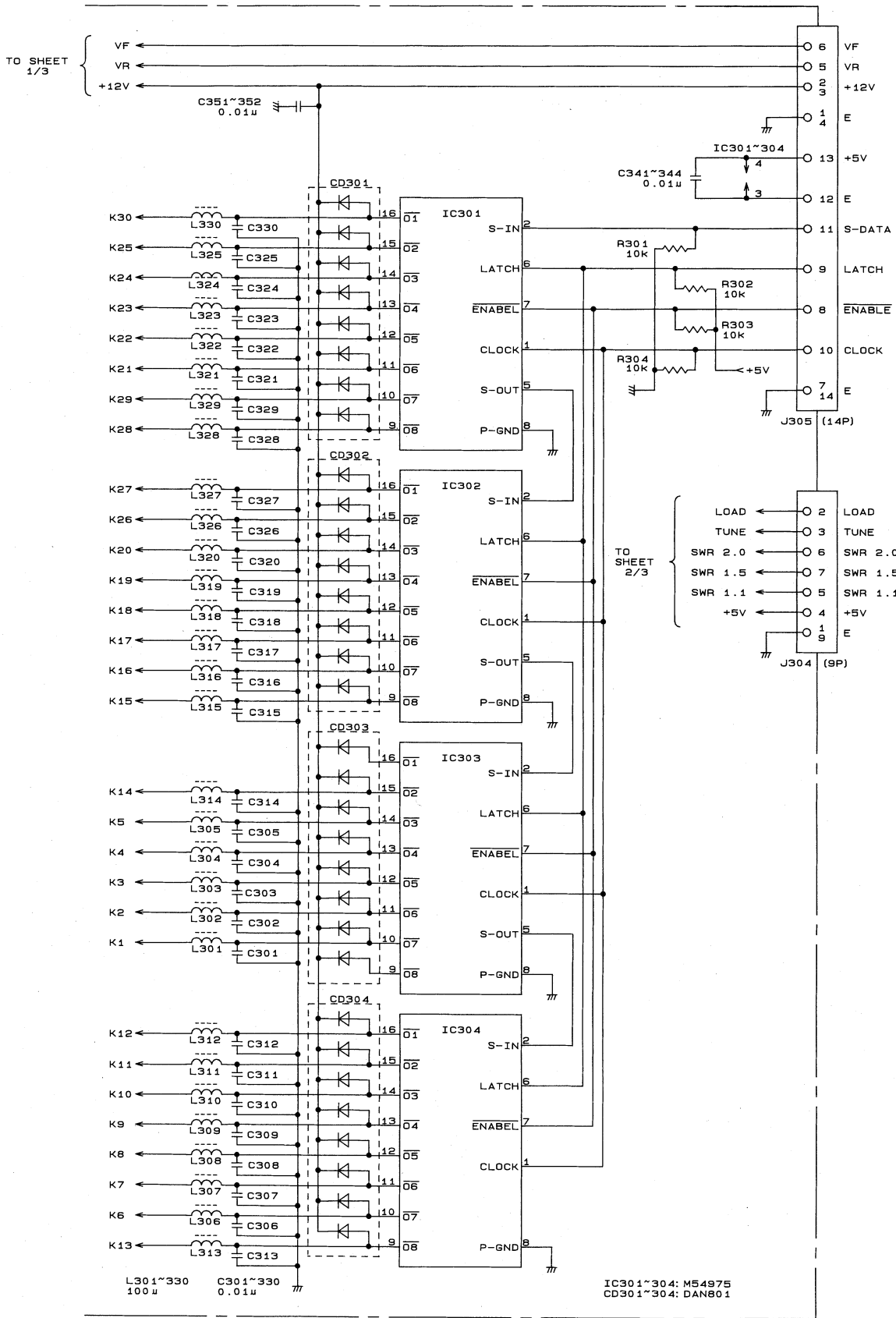

# 12-3 CSC-433 ANTENNA SWITCH

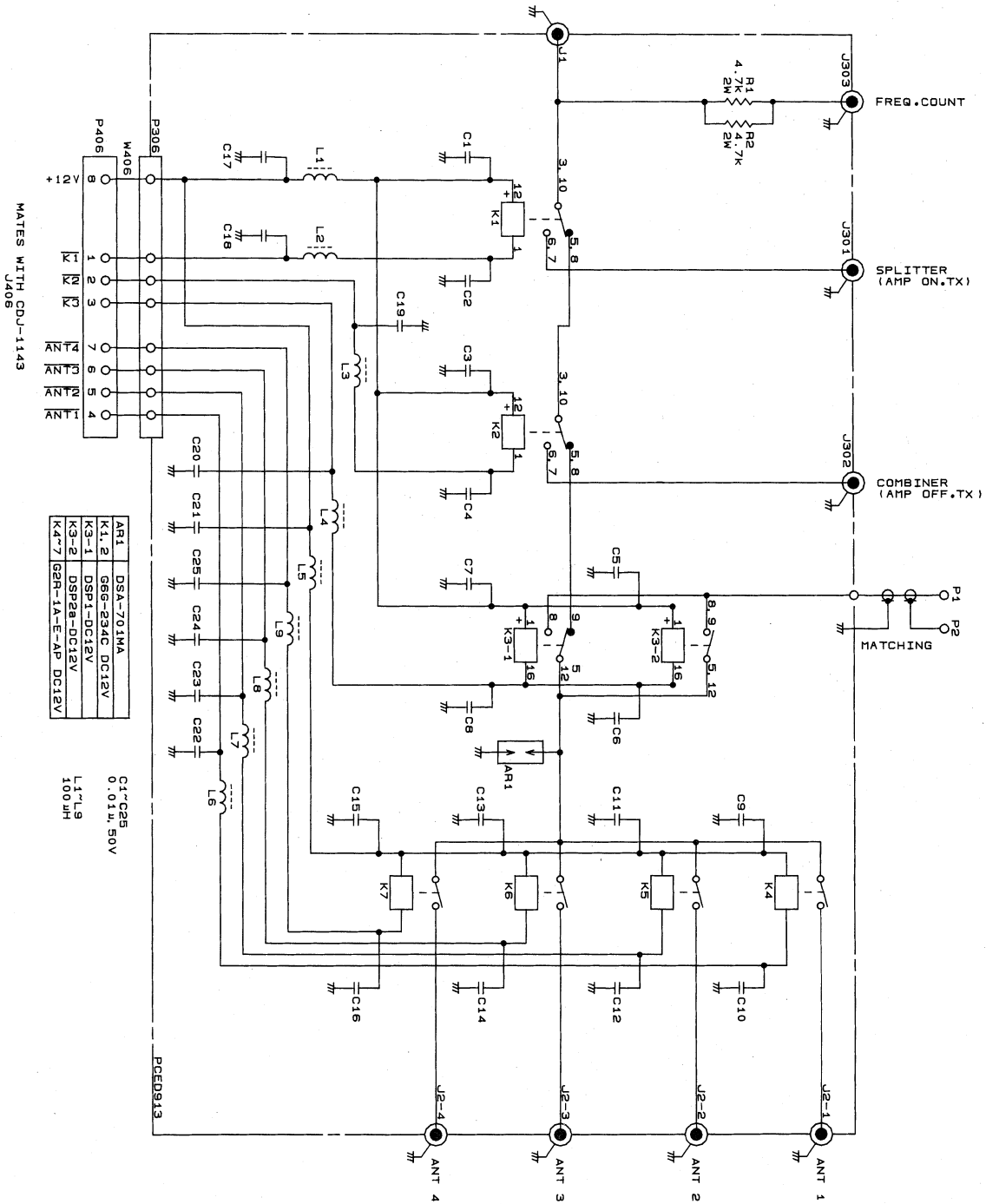

12-3 CDJ-1143 CONTROL (1/2)

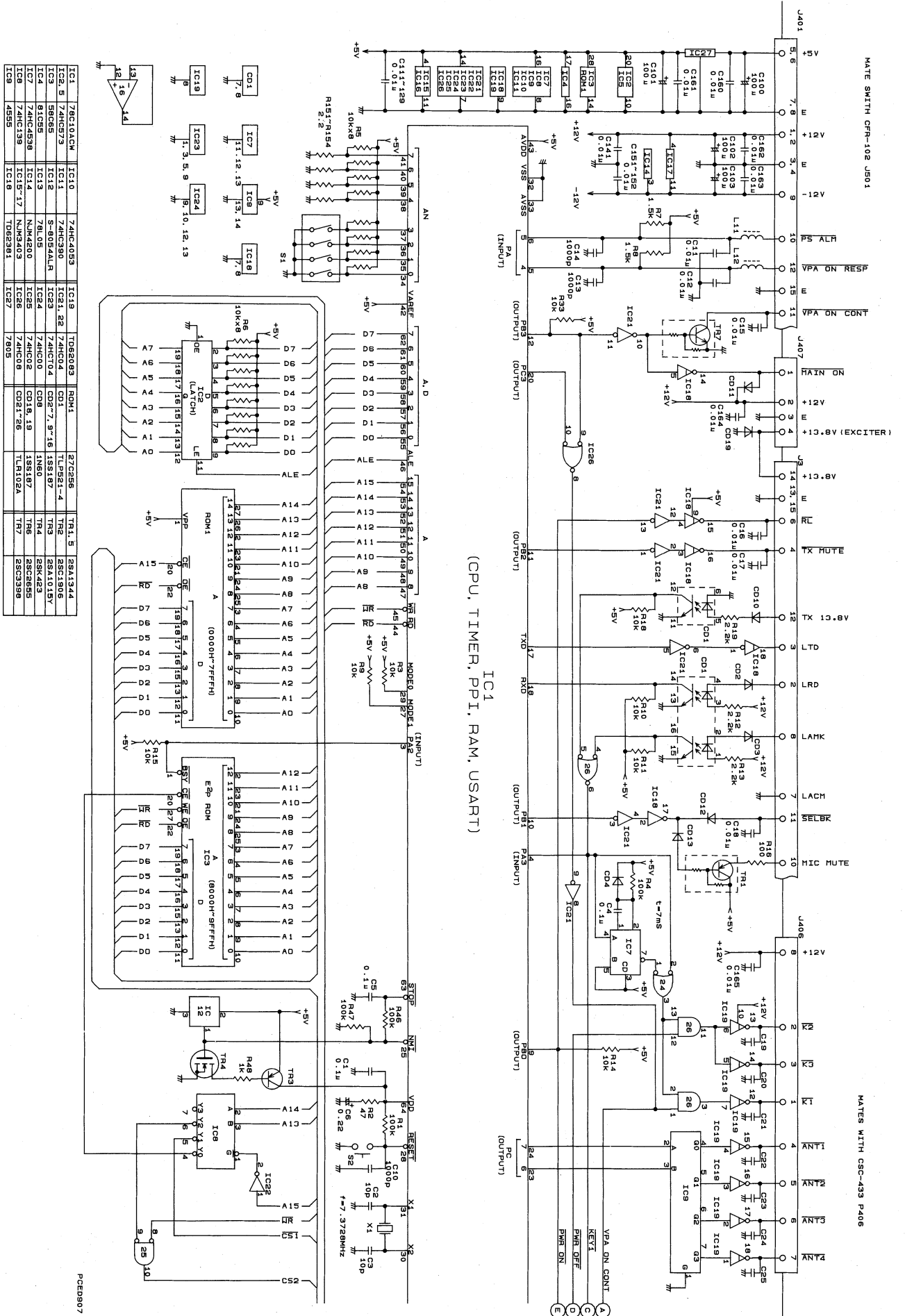

PCES907

# 12-3 CDJ-1143 CONTROL (2/2)

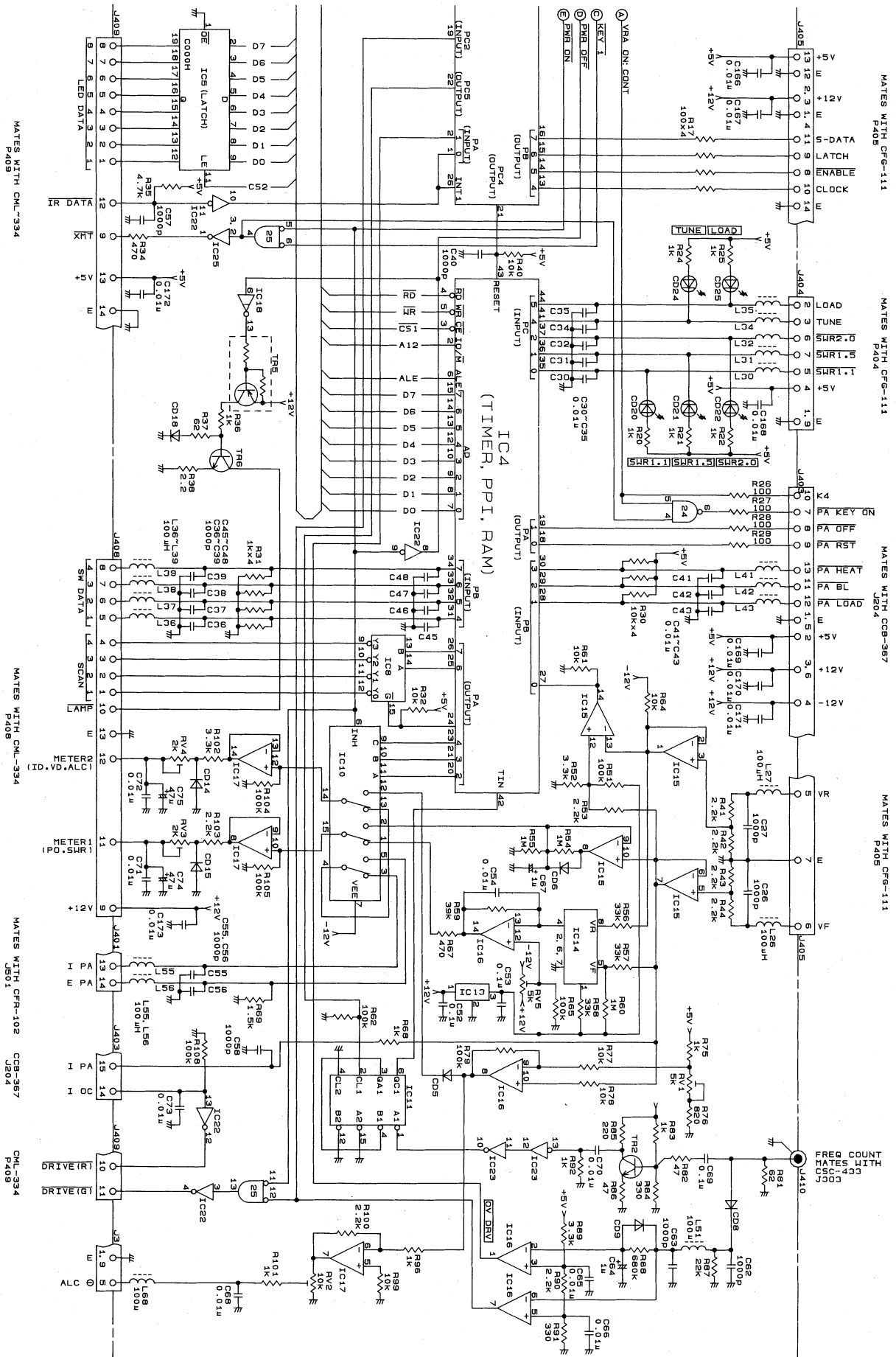

# 12-3 CML-334 DISPLAY

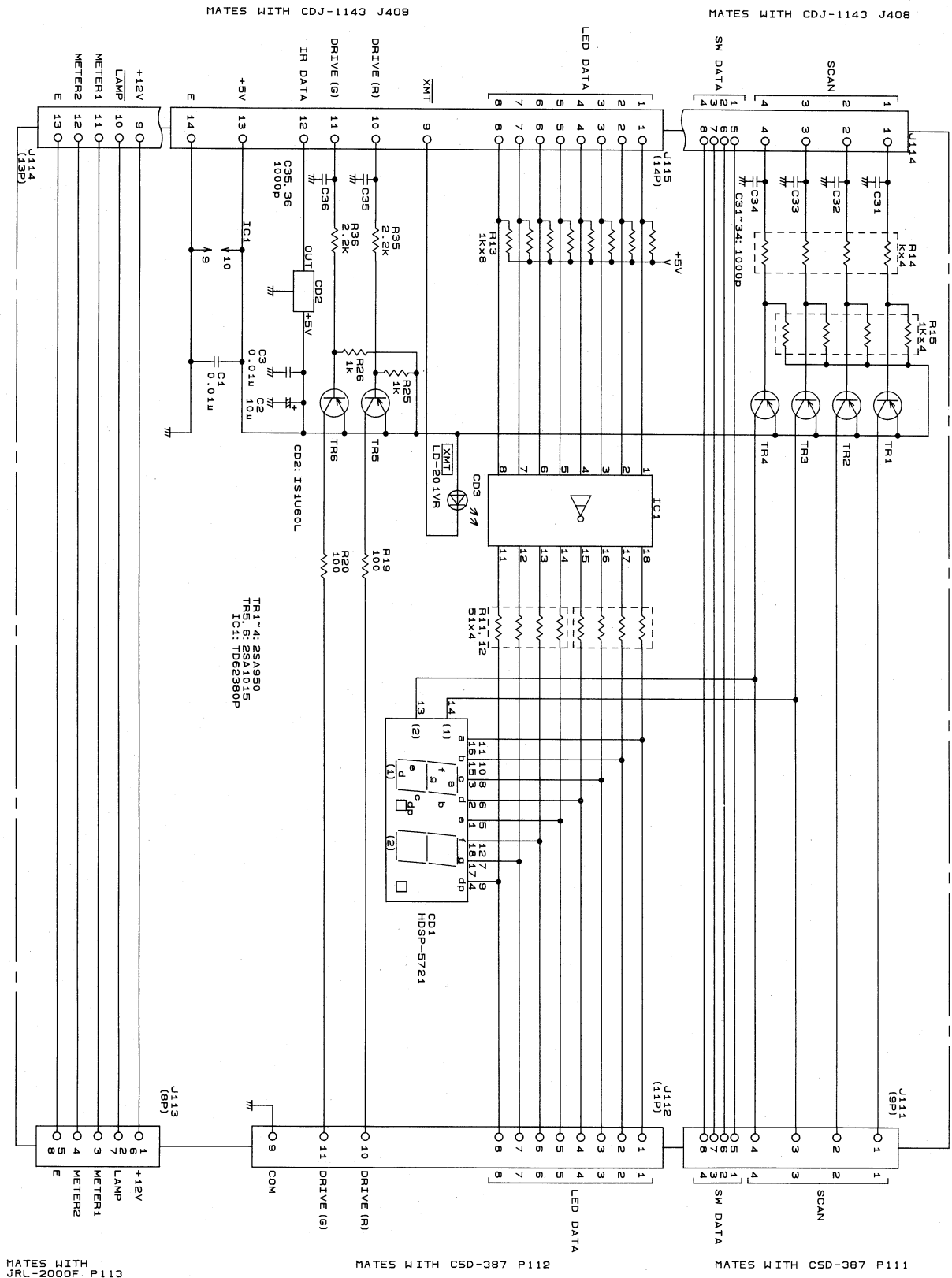

MATES WITH JRL-2000F P113

MATES WITH CSD-387 P112

MATES WITH CSD-387 P111



# 12-3 CSD-387 SWITCH PANEL

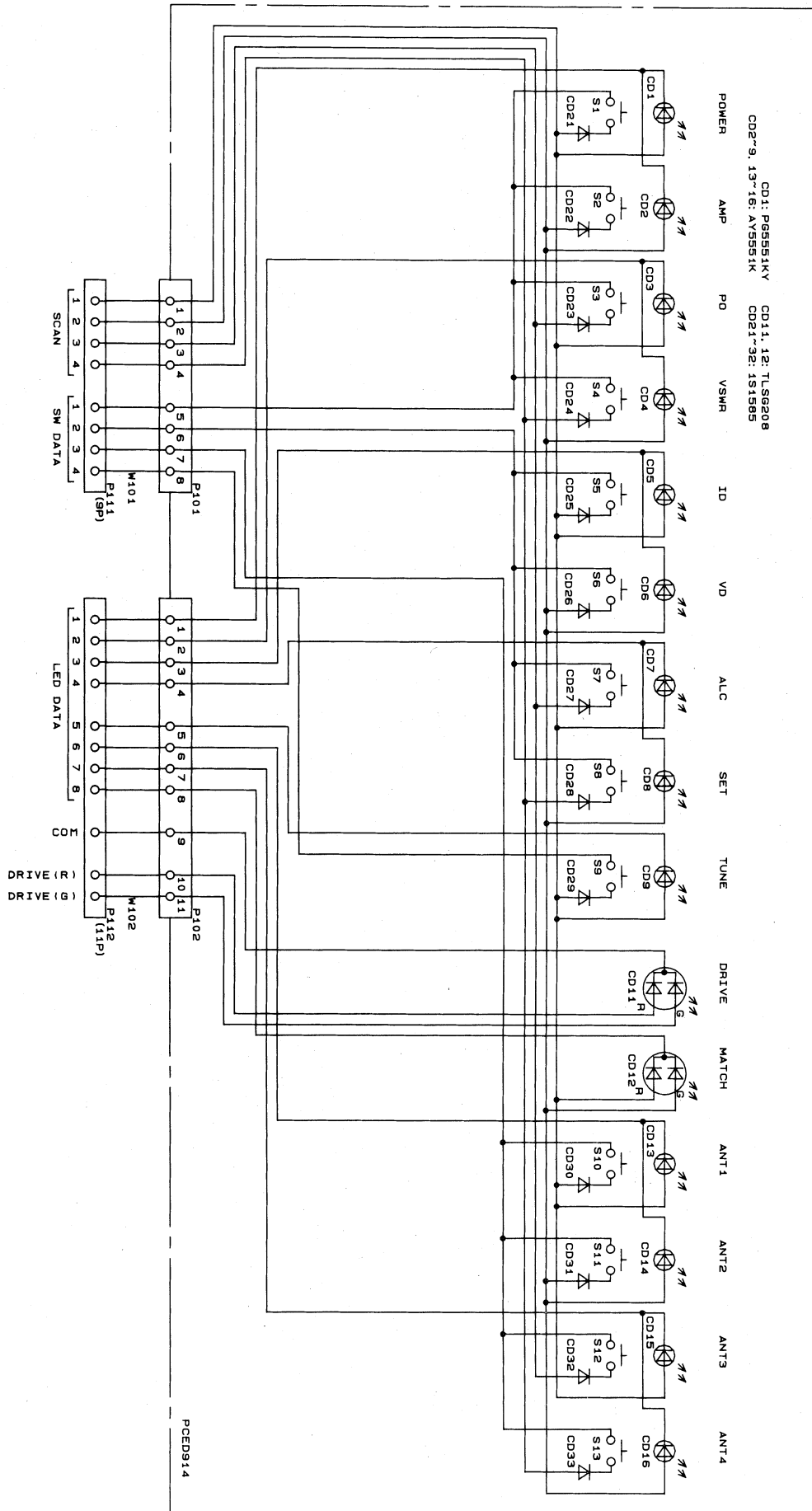

# 12-3 CSA-222 RELAY CIRCUIT

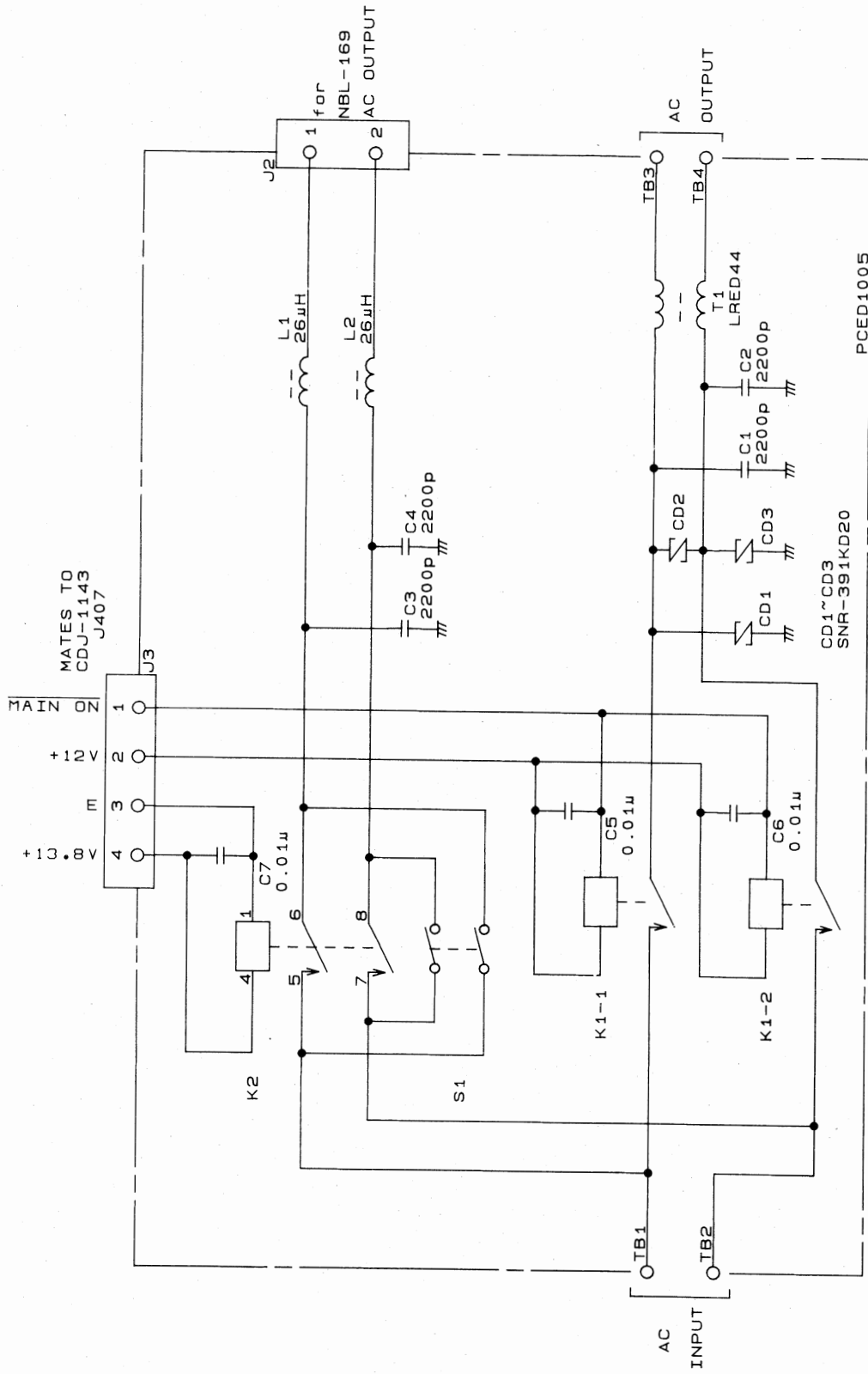

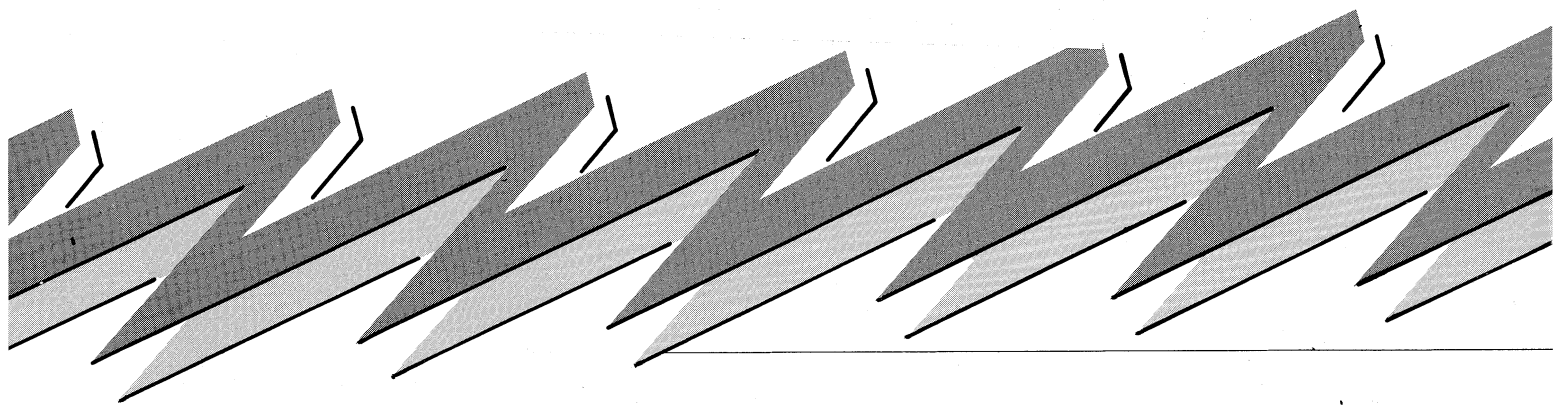

**JRC**

*Japan Radio Co., Ltd.*