

JRC

HF LINEAR AMPLIFIER

■ **JRL-2000F** ■

Service Manual



JRC

Japan Radio Co., Ltd.

Preface

This manual provides information required for maintenance and troubleshooting procedures of the JRL-2000F. Refer to the instructions manual for operation.

Contents

Preface	1
1. Specifications	3
2. Circuit Description	4
2.1 Configuration and Outline	4
2.2 NAH-232 Power Amplifier Unit	4
2.2.1 CAH-377 Power Amplifier	4
2.2.2 CCB-367 PA Control	6
2.2.3 CFF-361 Power Combiner	9
2.3 NBL-169 Power Supply Unit	9
2.3.1 CSA-222 Relay Circuit	10
2.3.2 CBB-13 Power Factor Corrector	10
2.3.3 CBG-68 Main PS Unit	11
2.3.4 CFR-102 Noise Filter	12
2.4 CFG-111 Matching Circuit	12
2.5 CSC-433 Antenna Switch	14
2.6 CDJ-1143 Control Circuit	15
2.7 Automatic Tuning	17
2.8 CML-334 Display	20
2.9 CSD-387 Switch Panel	20
3. Troubleshooting	21
4. Confirmation of Operation and Readjustment	26
4.1 Outline	26
4.2 Adjustment of 2 PA Units	26
4.2.1 Adjustment of Heat Sensor	26
4.2.2 Adjustment of Idling Current	27
4.3 Adjustment of Power Supply Unit	28
4.3.1 Adjustment of Output Voltage	28
4.4 Total Adjustment	28
4.4.1 Adjustment of Meter	28
4.4.2 Adjustment of APC Circuit	29
4.4.3 Adjustment of ALC Circuit	29
4.4.4 Adjustment of the VSWR Meter	29
5. External View	30
6. Block Diagram	34
7. Connection Diagram	37
8. Print Circuit Board Layout	55
9. Replacement Parts List	72

1. Specifications

Operating frequency bands	:1.8 MHz band 1.800 to 2.000 MHz 3.5 MHz band 3.500 to 4.000 MHz 7 MHz band 7.000 to 7.300 MHz 10 MHz band 10.100 to 10.150 MHz 14 MHz band 14.000 to 14.350 MHz 18 MHz band 18.068 to 18.168 MHz 21 MHz band 21.000 to 21.450 MHz 24 MHz band 24.890 to 24.990 MHz 28 MHz band 28.000 to 29.700 MHz
Rated output power	:SSB 1 kW PEP* 100% duty cycle; 24 hour. CW 1 kW* 100% duty cycle, 24 hour. FSK/SSTV 1 kW* 100% duty cycle, 1/4 hour.
Output impedance	:50 Ω unbalanced, VSWR 3.0 (16.7 to 150 Ω)
Harmonics	:-60 dB or less
Intermodulation distortion (IMD)	:-35 dB or less below PEP (at 1kW output)
Input impedance	:50 Ω unbalanced
Exciting power	:100W max.
Frequency switching time	: Less than 0.1 sec.
Power supply voltage	: 85 to 264 V AC, single-phase
Power consumption	:2.5 kVA or less (at 1 kW output)
Input power factor	:95% or more (at 1 kW output)
Temperature range	:-10°C to 40°C
Protection circuits	:PA excess current; PA overheat; PA abnormal load; AC power supply excess voltage; power supply overheat; PA failure; excessive antenna VSWR; exciting power excess; and antenna matching anomaly.
Dimensions	:430(W) X 300(h) X 402(D) mm
Weght	: Approx. 28Kg

* Note :Rated output on 200 to 240V AC. The rated output power on 100 to 120V AC is 750W PEP.

2. Circuit Description

2.1 Configuration and Outline

The cabinet of the JRL-2000F consists of a front panel, a top cover, a bottom cover, a rear panel and a main chassis.

The equipment of the cabinet consists of the following five units:

Unit Name	Installation Position
Power amplifier	At the bottom of the main chassis on the righted side
Power supply unit	At the bottom of the main chassis on the left-hand side
Matching circuit	Upper part of the main chassis
Antenna switch	Upper part of the rear panel
Control	Upper part of the main chassis
Switch panel	Front panel
Display	

The operation of each unit will be described below. Refer to the External View (page 30) for the general configuration and Print Circuit Board Layout (page 55) for the parts layout of the unit, respectively.

2.2 NAH-232 Power Amplifier Unit

This unit is attached to the lower part of the main chassis on the righthand side. It amplifies the drive input power sent from the exciter up to the rated output power by the wide-band linear power amplifiers.

This unit consists of two CAH-377 power amplifiers attached to each heat sink respectively, a CCB-367 PA control circuit attached to the upper side of the heat sink, a CFF-361 power combiner circuit attached to the bottom side of the heat sink, and a cooling fan.

2.2.1 CAH-377 Power Amplifier

CAH-377 power amplifier consists of two identical wide-band linear amplifiers which operate independently of each other on the printed circuit board. Each wide-band amplifier has 12 RF power MOSFETs and amplifies a 20 W PEP input power to 250W PEP.

The RF power MOSFET is new generation's power device which has excellent resistance to thermal stress and reflected power, a high linearity and a low high-order intermodulation distortion(IMD), as compared with the conventional bipolar transistor. As the two wide-band linear amplifiers have the same circuit, the circuit operation will be described for the left part of the connection diagram on page 39.

The input power signal from J1 is sent to the input transformer T1, and divided into two signals with 180° phase difference.

C1, C2, C5, R1 and R2 compose of a circuit which matches an input impedance. T11 and T21 are transformers which insulate the excitation signal from ground level. The two excitation signals are consumed by R17 to R20 and R27 to R30 which are the gate terminating resistors of the RF power MOSFET.

As a RF has the insulated gate, it can be assumed that only the equivalent input capacitance exists between gate and source.

The gate terminating resistor shunts this input capacitance.

The RF power MOSFET TR11 to TR16 are connected parallel. They are excited by the signal voltage at both ends of the gate terminating resistor and they amplify the output current in a half cycle. On the other hand, TR21 to TR26 amplify the output current in another half cycle. These output currents of half-cycles are fed to the primary winding of the output transformer T5 and the current waveform of full-cycle is composed. These output currents flow to the load circuit via output terminal J4.

As a result, the upper part of the output voltage waveform is amplified by TR11 to TR16, and the lower part by TR21 to TR26.

The SEPP circuit, in contrast to the transformer-coupled push-pull circuit, seldom generates a phase difference when composing output waveforms. Therefore, a waveform with less distortion can be obtained.

The transformer T3 provides a gate-bias voltage to the RF power MOSFET for the operation in class AB.

A DC bias voltage of approx. 2.5 V is provided through T3 to each RF power MOSFET from CCB-367 PA control circuit. The resistors R61 and R62, connected between the third winding of T3 and the second winding of the input transformer T1, work as a negative feedback.

(Note): The chips with same characteristics are packaged to the RF power MOSFET 2SK408 and 2SK409. However, the lead layout differs.

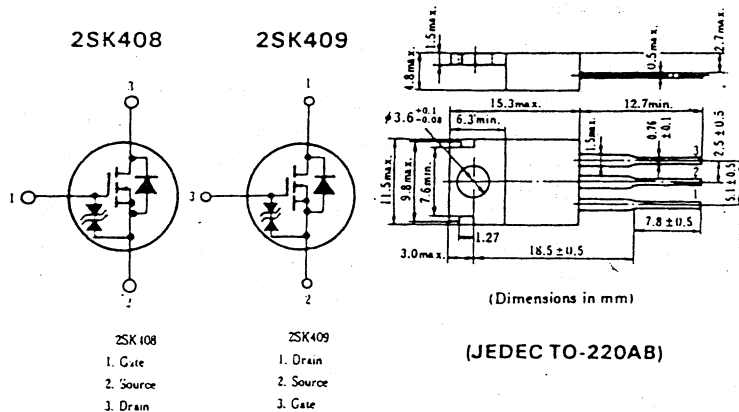

Fig.1

2.2.2 CCB-367 PA Control

CCB-367 PA control is attached to the upper side of the power amplifier unit and is equipped with a bias voltage control circuit for the two power amplifiers, a cooling fan control circuit, protection circuits and an input power splitter.

1) Power Amplifier Bias Voltage Control Circuit

As the RF power MOSFET of CAH-377 power amplifier operates in class AB, the DC bias voltage which determines the operating point current (idling current) is essential. The gain of the power amplifier can be changed by changing the DC bias voltage. The normal bias voltage is about 2.5V DC. However, the bias voltage varies according to the KEY signal state or the temperature change of the heat sink to get the optimum gain of the power amplifier.

IC4(1/4 to 4/4) and IC5(1/4 to 4/4) are DC amplifiers which send out a bias voltage to the RF power MOSFET block of each SEPP circuit. This bias voltage can be adjusted with variable resistors RV11 to RV14 and RV21 to RV24. The reference voltage for this bias voltage is obtained from the developed voltage between the base and the emitter of TR1 and TR2. TR1 and TR2 are attached to the side part of the heat sink of CAH-377 power amplifier. As the base-emitter is driven by a constant current, the base-emitter voltage depends on the temperature of the heat sink.

The base-emitter voltage is amplified by the DC amplifier IC3 (4/4) and sent to each power amplifier block as a bias voltage.

As the RF power MOSFET, employed in the JRL-2000F, has a negative thermal coefficient, the gain decreases when the temperature of the heat sink rises. To compensate this, TR1 and TR2 check the temperature of the heat sink and operate to keep the gain constant, regardless of the temperature change, by controlling the bias voltage.

The comparator IC3 (3/4) controls the bias voltage by referencing the KEY signal.

Fig.2 shows each waveform of the signal voltage.

KEY & PTT signal (A) from outside, passes the time-constant circuit composed of C1 and R2, and is switched by the comparator. The comparator output (B), sent out from No.14 pin of IC1, passes the time-constant circuit composed of R5, CD14 and C2, and the DC amplifier IC3 (4/4) and then is formed to a signal voltage waveform (C).

The signal voltage waveform (C) is applied to the DC amplifiers IC3 (3/4) and IC (4/4), and controls the bias voltage of each power amplifier block. The bias voltage (D) varies according to the KEY & PTT signal.

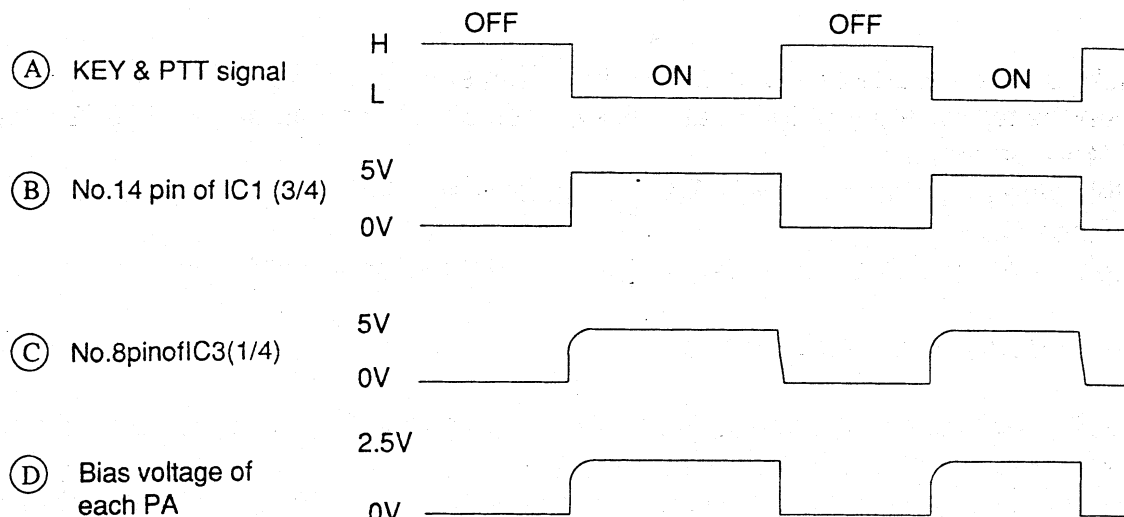

Fig.2

2) APC (Automatic Power Control) Circuit

The APC circuit prevents excessive output by controlling the bias voltage of the power amplifier when the output of the linear amplifier exceeds the rated value.

The output power signal V_f , detected by the CFG-111 matching circuit, is fed to the comparator IC1 (4/4) and compared with the reference voltage adjusted by the variable resistor RV3.

When the V_f signal exceeds the rated value, the comparator is turned on and the comparator output voltage controls IC3 (3/4) and IC3 (4/4) (DC amplifier to control the bias voltage). As a result, the bias voltage drops and the output power is controlled to be constant in case of excessive output.

When the comparator is on, the OVER DRIVE signal is sent to the switch panel via diode CD1, and lights up the DRIVE LED in red.

3) Temperature Detector Circuit.

The base-emitter voltage of the temperature detector transistor TR1 and TR2 attached to each of the two heat sinks is compared by the comparators IC6 (1/4) and IC6 (2/4), and IC6 (3/4) and IC6 (4/4), respectively.

As TR1 and TR2 have a negative temperature coefficient of about $-4.5 \text{ mV}/^\circ\text{C}$ (degree centigrade) the base-emitter voltage drops when the temperature of the heat sink rises.

Variable resistors RV1 and RV2 set the reference voltage of the comparators IC6 (2/4) and IC6 (4/4) to the base-emitter voltage which corresponds to the temperature of 80°C of the heat sink.

At this time, the reference voltage of the comparators IC6 (1/4) and IC6 (3/4) is the same as that which corresponds to the voltage when the temperature of the heat sink is 50°C . Therefore, when the temperature of the heat sink exceeds 50°C , the comparator IC6 (1/4) or IC6 (3/4) is turned on, and "High" level voltage is applied.

to turn on the transistor TR3 and the cooling fan starts to rotate.

When the temperature of the heat sink exceeds 80 °C, the comparator IC6 (2/4) or IC6(4/4) turns on.

At this time a Low level $\overline{\text{PA HEAT}}$ alarm signal is sent to the CDJ-1143 control circuit via diode CD7.

When the PA HEAT alarm is issued, the JRL-2000F displays "A3".

4) PA UNBL Alarm Detector Circuit

The CFF-361 power combiner is equipped with a sensor R7 which detects unbalanced power when the power is combined.

This sensor detects the unbalanced power and when the terminal voltage of the sensor increases, the comparator IC1 (2/4) turns on, and the $\overline{\text{PA BL}}$ alarm signal is generated.

When the $\overline{\text{PA BL}}$ alarm is issued, the JRL-2000F displays "A4".

5) PA LOAD Alarm Detector Circuit.

The CFF-361 power combiner is equipped with a circuit which detects V_f and V_r of the PA output terminal.

V_f and V_r are compared by the comparator IC2 (2/4).

When the VSWR value exceeds 3.0 at the PA output terminal because of a poor matching situation with the matching circuit, the ratio V_r/V_f exceeds 0.5 and the comparator IC2 (2/4) changes from Low level to High level.

This comparator output signal triggers the flip-flop circuit composed of IC2 (3/4) and IC2 (4/4), and turns over the output voltage to issue the $\overline{\text{PA LOAD}}$ alarm signal.

When the PA LOAD alarm is issued, the JRL-2000F displays "A9".

IC2 (1/4) and the peripheral devices compose of a circuit which resets the flip-flop.

6) PA OFF Circuit

When one of the three alarm signals of the PA control becomes Low level, or when $\overline{\text{PA OFF}}$ signal which forcedly turns off the power amplifier becomes Low level because of the operation of the other protection circuit, a Low level signal is sent to the input terminal of the comparator IC1 (4/4) via CD4 or CD6 diode OR circuit and the output of IC1 (1/4) turns from Low level to High level.

This signal is applied to the DC amplifier which controls the bias voltage of the power amplifiers IC3 (3/4) and IC3 (4/4), and the bias voltage of the power amplifiers is set to -9V.

If the bias voltage becomes -9V, the RF power MOSFET of the power amplifier is cut off and the output power becomes 0 W, regardless of the existence of the excitation power.

7) Power Splitter Circuit

The excitation power supplied to J201 terminal from the exciter is applied to the RF transformer T1 via -2dB attenuator circuit.

T1 is an impedance convert transformer (50 ohms : 12.5 ohms).

The excitation power is distributed to each terminal P21 to P24.

2.2.3 CFF-361 Power Combiner

The CFF-361 power combiner is attached to the bottom of the power amplifier unit. This circuit generates a 1kW PEP by combining the output power from the power amplifier of the four SEPP circuits.

These power amplifier output currents are combined by the RF transformers T1 and T2, and finally combined by T3.

As the output impedance of T3 is 12.5 ohms, the step-up transformer T4 is converted to 50 ohms.

Resistors R1, R2 and R3 absorb the unbalanced power generated at both ends of each combining transformer.

R3 is equipped with a sensor R7 which detects temperature.

When a large unbalancing power is generated among these four power amplifier, R3 produces heat to increase the resistance of R7 and the PA BL alarm circuit is activated.

The circuit, consisting of a current transformer T5, diodes CD1 and CD1, capacitors C1 to C4 and resistors R51 to R54, detects V_f and V_r of the power combiner output terminal.

V_f and V_r issue the PA LOAD alarm when the VSWR of the power combiner output terminal is 3.0 or more. Relay K4 is turned on when the PA switch is on, and the combined power is sent to the matching circuit through this relay.

2.3 NBL-169 Power Supply Unit

The NBL-169 power supply unit is a regulated switching power supply whose power output of DC 80 V is generated using AC 100 V to 240 V. Because the pulse-shaped current flows to capacitors in a smoothing circuit in a power supply unit with a capacitor-input type smoothing circuit, the power factor of AC input is, in general, about 0.5 to 0.6.

The JRL-2000F has employed a power factor corrector circuit in the former stage of the switching regulator circuit to obtain a power factor of approx. 1.

The CBB-13 power factor corrector is attached to one side of the heat sink which is in the center of the unit, and the CBG-68 main PS unit is attached to the other side. The unit also incorporates a switching power supply unit which generates a DC +12 V (4A) power supply for the control circuit.

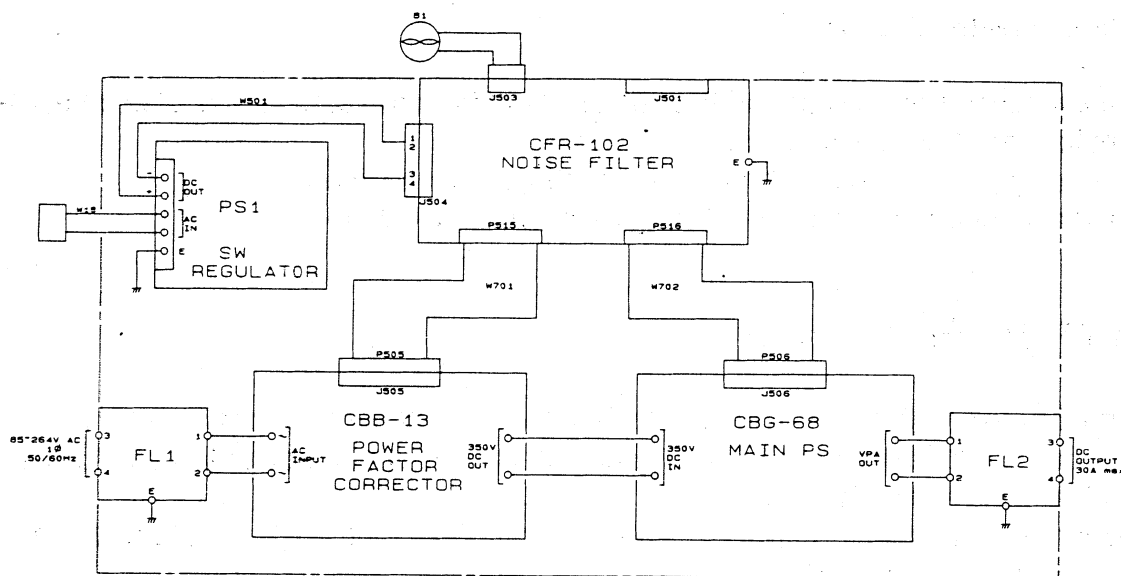

Fig.3 Block Diagram of NBL-169 Power Supply Unit

2.3.1 CSA-222 Relay Circuit

The CSA-222 relay circuit consists of a relay which turns on/off the AC power supply and a noise filter circuit.

The AC input voltage is applied to the terminal boards TB1 and TB2 and sent to the NBL-169 power supply unit via K1-1 and K1-2 relays.

As the relay K2 is activated by the DC 13.8 V provided from the exciter, the JRL-2000F can be turned on/off by the exciter main switch.

2.3.2 CBB-13 Power Factor Corrector

The CBB-13 power factor corrector converts AC100 to 240V to DC 350 V by a DC-DC converter inserted in the smoothing circuit.

In this DC-DC converter, a PFC exclusive control IC of IC1 corrects the line current waveform to a sine-curved waveform.

Resistor R1 absorbs the rash current generated at the relay K1 when the AC power is turned on.

The MOSFETs TR1 to TR3 controlled by IC1, switch the current which flows through choke coils L1 and L2 with a frequency of about 90 kHz.

The switched MOSFET drain voltage charges the capacitors C1 to C3 via diode CD2. As a result, a DC350 V voltage develops at the output terminal of TE3.

The current transformer T1 measures the MOSFET switching current value and detects the excessive current by the feedback of the value to IC1.

The circuit composed of R11 to R13 detects an AC voltage waveform and sends it to IC1. The IC1 controls the current waveform based on this waveform.

Resistors R25 to R27 feed back the output voltage to IC1.

The comparator IC5 detects an excessive output voltage and sends out the PS ALM signal via CD4 photocoupler.

R30 is a sensor which detects a MOSFET overheat. When the temperature of the FET case exceeds 80 °C, the terminal voltage of R30 increases and the transistor TR8 is turned on.

The circuit composed of IC2, TR6, TR7, T2 and IC4 is a switching regulator which generates a DC-12 V voltage.

2.3.3 CBG-68 Main PS Unit

The CBG-68 main PS unit is a regulator which generates a regulated output of DC 80 V(30A) based on the CBB-13 power factor corrector output of DC 350 V.

IC201 is a control IC and it sends out pulses for the 150 kHz switching control circuit. MOSFETs TR205 and TR206 and transformers T202 and T203 compose a MOSFET drive circuit for a main switching circuit and amplify two phase switching pulses from IC201.

TR201 to TR204 are power MOSFETs for a main switching circuit and compose of a full-bridge switching circuit with an output transformer T201.

The output pulse from the secondary winding of T201 is rectified to DC by diodes CD301 and CD302, and smoothed by capacitor C206.

R232 is a sensor which detects a power MOSFET overheat of the main switching circuit. When the temperature of the MOSFET case exceeds 80 °C, the terminal voltage of R232 increases and transistor TR 209 turns on.

TS201 is a thermostat which detects overheat of the heat sink. It turns on at 45 °C and drives the cooling fan.

R231 is a resistor which detects a DC output current. The voltage detected by this resistor is amplified by IC202 amplifier and it moves the pointer of the ammeter (ID) on the front panel and at the same time detects an excessive current of the comparator IC203. When the output current exceeds 30A, IC203 is turned on and it triggers the control IC201 via the time constant circuit made up of TR207 and TR208 to terminate switching oscillation.

At this time, the output of the transistor TR208 is applied to No.8 pin of IC203 which then issues an over current alarm.

The output voltage is divided by the variable resistor RV201 and resistors R233 to R235 and the constant-voltage control by IC201 is achieved by the feedback of the divided voltage to IC201.

The output voltage can be changed between DC 50V to 80V by adjusting RV201. Resistors R236 to R238 divide the output voltage and the divided voltage moves the pointer of the voltmeter (VD) on the front panel and activates the excessive voltage detector circuit after entering No.10 pin of IC203.

When the output voltage exceeds 90 V, No.13 pin of IC203 becomes Low level and an alarm signal for an excessive voltage is issued. At the same time, the divided voltage is also applied to No.6 pin of IC203 which then sends out the VPA ON RESP signal indicating that the comparator output voltage is turned on.

The start circuit of the JRL-2000F consists of transistors TR210 to TR212 and peripheral parts.

When the PA switch on the front panel is turned on, the $\overline{\text{VPA ON CONT}}$ signal changes from High to Low level and the collector voltage of TR210 increases.

This voltage turns on TR211 via the time-constant circuit and also turns on the relay K1 of the CBB-13 power factor corrector. TR211 also turns on TR212 and activates IC201 by providing it with a DC power supply.

2.3.4 CFR-102 Noise Filter

The CFR-102 noise filter is attached inside of the power supply unit.

The noise filter circuit is composed of an L-C circuit and it prevents the switching noise component generated inside of the power supply unit from leaking out.

2.4 CFG-111 Matching Circuit

The CFG-111 matching circuit is attached to the upper part of the main chassis. It attenuates the unwanted harmonics components contained in the output of the power amplifier and matches the antenna impedance to 50 ohms.

The matching circuit consists of an RF matching circuit, an impedance detector circuit, a relay drive circuit and an output power detector circuit.

The block diagram is shown in Fig.4.

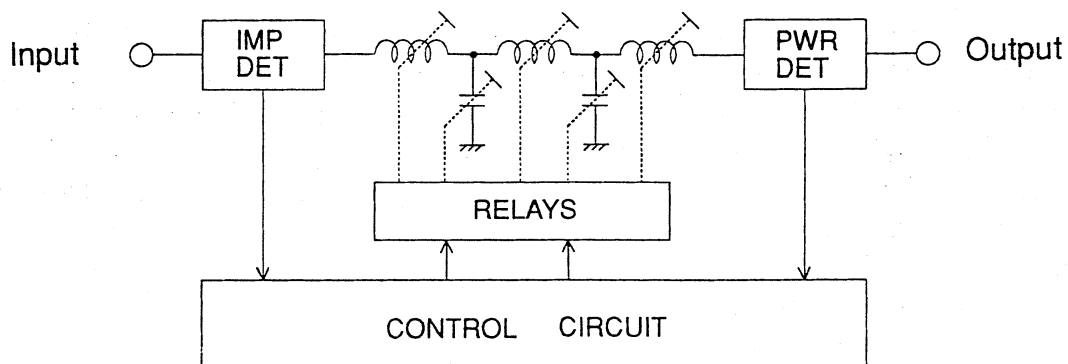

Fig.4 Block Diagram CFG-111 Matching Circuit

(1) RF Matching Circuit

This circuit consists of inductors and capacitors which are binary-combined by relay contacts, forming an L- π -L low pass filter as shown in Fig.5.

Each relay is controlled by the control program and activated by CPU instructions.

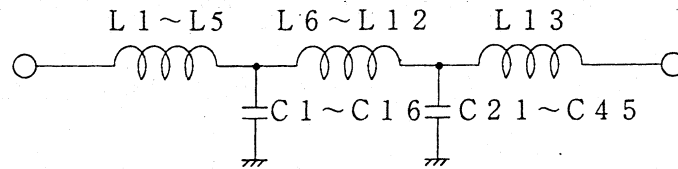

Fig.5 L- π -L Low Pass Filter.

(2) Impedance Detector Circuit

The impedance detector circuit detects the impedance of the matching circuit input terminal and the output signals are sent to the CDJ-1143 control CPU.

The circuit made up of diodes CD401 and CD402, IC403 and peripheral parts measures impedance.

The voltage at the input terminal is detected by capacitors C401 and C402 and diode CD401. On the other hand, the current at the input terminal is detected by the current transformer T1 and diode CD402.

The detected voltage and current are compared by IC403 comparator.

The LOAD signal changes to Low level when the impedance at the input terminal is over 50 ohms, and the signal changes to High level when it is below 50 ohms.

The circuit made up of IC401, IC402 and IC403 and peripheral parts detects the phase of the impedance.

After the voltage and current at the input terminal are wave-shaped by IC401, they are applied to IC402 where the D-type flip-flop detects the phase of the voltage and current.

When the phase of the current is advanced to that of the voltage, the TUNE signal is High level, and it changes to Low level when the phase is behind the voltage phase.

The circuit made up of diodes CD421, CD441, IC404, IC405 and peripheral circuit parts detects the VSWR value of the input terminal.

Diode CD421 detects the forward voltage (V_f) and diode CD441 detects reflected voltage (V_r). V_f and V_r are compared by IC404 comparator and three output signals, SWR1.1, SWR1.5 and SWR2.0 are obtained. The Low level of SWR1.1 signal means that the VSWR value of the input terminal is below 1.1.

(3) Relay Drive Circuit

The circuit made up of IC301 to IC304 drives relays.

Each IC receives serial input data and sends out an 8-bit latched parallel signal. The CDJ-1143 control CPU sends 32-bit relay data to the ICs in serial signals.

(4) Output Power Detector Circuit

The output power detector circuit detects V_f and V_r of the matching circuit output terminal.

Capacitors C201 and C202 detect the voltage of the output terminal and transformer T2 detects current.

Diodes CD201 and CD202 detect the forward voltage (V_f) and the reflected voltage (V_r).

V_f and V_r are sent to the CDJ-1143 control circuit where the VSWR value is calculated, and then they are displayed in the voltmeter on the front panel.

2.5 CSC-433 Antenna Switch

The CSC-433 antenna switch is a relay circuit which switches RF signals and is controlled by the CDJ-1143 control CPU. Connector J1 is an input terminal of the RF power which is sent from the exciter. J2-1 to J2-4 are the output terminals to which four antennas can be connected.

Resistors R1 and R2 detect the exciter output power and send it to the CDJ-1143 via J303.

The contact of the relay K8 becomes open state during receiving state.

Depending on the mode used, each relay operates as follows.

(1) In the Antenna Switch Mode

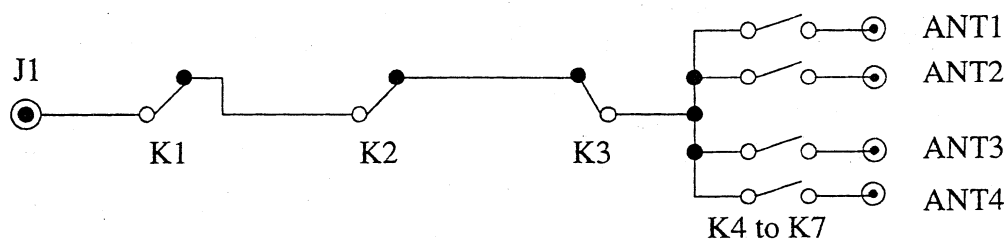

Fig.6

(2) In the Antenna Tuner Mode

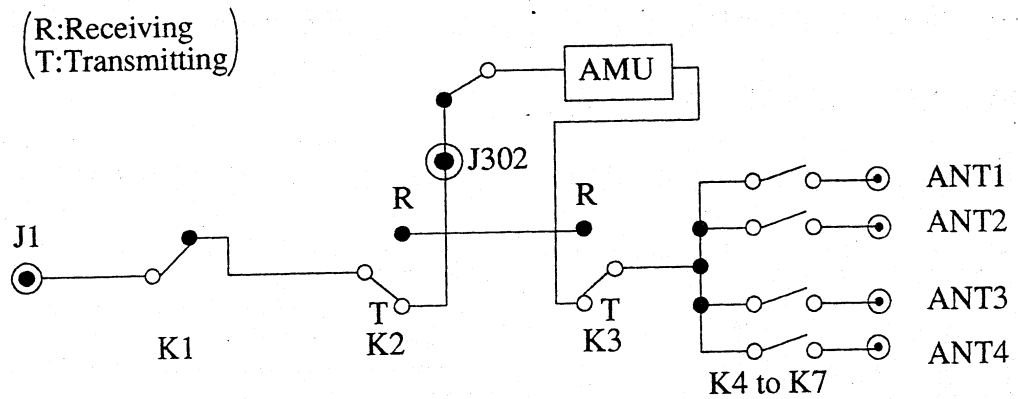

Fig.7

(3) In the Linear Amplifier Mode

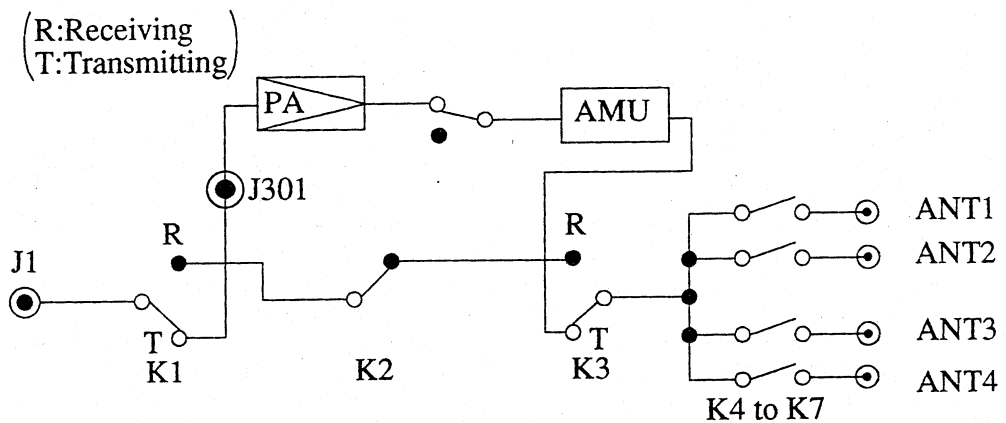

Fig.8

2.6 CDJ-1143 Control Circuit

The CDJ-1143 control circuit is on the printed circuit board attached to the upper part of the JRL-2000F. It incorporates an 8-bit microprocessor and controls the JRL-2000F and monitors its operation.

(1) Microprocessor Circuit

IC1 is an 8-bit single-chip CPU and equipped with I/D ports, a timer, random access memories and serial communication terminals. Control programs are stored in ROM1.

IC3 is a memory IC which supports electrical write/erase, and the tuning date of each band is stored in it. Switch S1 provides initial conditions to the CPU of the JRL-2000F. IC2, TR3, TR4, S2 and peripheral parts compose of a CPU reset circuit, and IC2 detects the drop of the CPU operating voltage DC 5V.

(2)Description of I/O Signals

Refer to the instructions manual for the connecting signals with the exciter.

Signal name	I/O	Description
$\overline{\text{PS ALM}}$	Input	Alarm from NBL-169
$\overline{\text{VPA ON RESP}}$	Input	Response of PA power supply voltage
$\overline{\text{VPA ON CONT}}$	Output	Truns on CBG-68
$\overline{\text{MAIN ON}}$	Output	Truns on the relay which provides NBL-169 with AC power supply
$\overline{\text{K1}}$	Output	Truns on K1 of CSC-433
$\overline{\text{K2}}$	Output	Truns on K2 of CSC-433
$\overline{\text{K3}}$	Output	Truns on K3 of CSC-433
$\overline{\text{ANT1}}$	Output	Truns on ANT1 of CSC-433
$\overline{\text{ANT2}}$	Output	Truns on ANT2 of CSC-433
$\overline{\text{ANT3}}$	Output	Truns on ANT3 of CSC-433
$\overline{\text{ANT4}}$	Output	Truns on ANT4 of CSC-433
S-DATA	Output	Sends data to the relay IC of CFG-111
LATCH	Output	Latches S-DATA signal in the IC memory
$\overline{\text{ENABLE}}$	Output	Enable output of the relay drive IC of CFG-111
$\overline{\text{K4}}$	Output	Truns on relays in CFF-361
$\overline{\text{PA KEY ON}}$	Output	Truns on PA bias circuit
$\overline{\text{PA OFF}}$	Output	Truns PA bias voltage to minus voltage
$\overline{\text{PA HEAT}}$	Input	Alarm for overheat of PA heat sink
$\overline{\text{PA BL}}$	Input	Alarm for PA unbalanced
$\overline{\text{PA LOAD}}$	Input	Alarm for PA abnormal load impedance

(3)SWR Detector Circuit

Vf and Vr detected by the output power detector circuit of CFG-111 are compared by comparator IC15.

When the VSWR value which is a ratio of Vf to Vr, exceeds 3.5, No.4 pin of IC15 becomes Low level to inform CPU of the SWR alarm (A8).

On the other hand, Vf and Vr are applied to the SWR operating circuit made up of IC14, IC17 and peripheral parts. The calculated SWR is indicated in the voltmeter on the front panel.

The circuit made up of IC15, CD6, R54, R55 and C67 holds the peak of Vf.

Data selector IC of IC10 selects signals which are connected to the front panel meter. Comparator IC16 which has an output terminal (No.8 pin) compares Vf with the reference voltage adjusted by the variable resistor RV1. If Vf exceeds the reference voltage, an ALC voltage is generated.

The ALC voltage moves the pointer of the voltmeter via diode CD5 and it is inversely amplified to a negative voltage by IC17 operational amplifier and then sent to the exciter.

(4)Frequency Measurement Circuit

The RF signal from the exciter, which is detected by the CSC-433 antenna switch circuit, is applied to J410, and is then amplified by transistor TR2.

The signal is wave-shaped to the rectangular wave by the IC23 two-stage buffer amplifier.

After the divider of IC11 divides this signal ten times, it is applied to the timer IC of IC4.

IC4 is controlled by CPU and measures frequency of the exciter output signal by counting this signal.

2.7 Automatic Tuning

The CDJ-1143 control CPU of the JRL-2000F automatically tunes the antenna by controlling relays of the CFG-111 matching circuit according to the program written to ROM1.

SET and TUNE operations will be described here.

(1)SET

When the SET switch is pressed, No.11 pin (SELBK) of the CDJ-1143 control J3 changes to Low level and requires power from the exciter.

The exciter enters transmit state and the LED of XMT on the front panel lights up for as long as the signal line of No.11 pin (SELBK) of J3 is correctly connected to the exciter. The power from the exciter is divided by R1 and R2 of the CSC-433 antenna switch circuit and R61 of the CDJ-1143 control circuit, and the frequency of the signal is measured.

Refer to "2.6 CDJ-1143 control (4)" for the frequency measurement.

IC16 of CDJ-1143 control circuit checks the divided signal level and if the input power is too small (below about 20 W), No.7 pin of IC16 changes to High level. If it is too large (over about 150 W), No.1 pin of IC16 changes to Low level. CPU checks the state of the signal at times and displays Po with the seven-segment LED on the front panel when the input is too small, and A6 when it is too large. After frequency measurement is completed, the data of EEPROM is checked in relation with the obtained frequency. In EEPROM, the data is memorized in a matrix as shown in Fig.9. For example, assume that the frequency is 14.020MHz. As the related data exists in the No.2 antenna column, the antenna circuit is switched to No.2 antenna and relays of the CFG-111 matching circuit are preset according to the data. The frequency display is also switched. In addition, the antenna number last used is stored in RAM incorporated in CPU and it will be selected if two or more data exist for one frequency.

The data capacity of 30-bit is required for one cell because there are 30 relays in CFG-111 matching circuit and one more bit is added to indicate that there is data or not. The bit is set to "no data" for all cells on shipping. When the automatic tuning is completed, the bit changes to "data exists" state. As the 8-bit/1 word EEPROM is used here, four words will be assigned to a matrix.

Frequency	Antenna number			
	1	2	3	4
1.600~1.610MHz	FFFFFFFF	FFFFFFFF	FFFFFFFF	FFFFFFFF
14.000~14.080MHz	FFFFFFFF	0543F2D6	FFFFFFFF	FFFFFFFF
29.900~30.000MHz	FFFFFFFF	FFFFFFFF	FFFFFFFF	FFFFFFFF

All the data is set to FFFFFFFF on shipping.

Fig. 9 Memory Map

(2)TUNE

When the TUNE switch is pressed, the LED of the TUNE switch lights up. If an exciter other than JST-135 is used, proceed to the step of "Operation of frequency measurement". The state of relays is preset according to the measured frequency without the steps of read-out of the memory and selection of the antenna. When the JST-135D exciter is used, the procedures described above are omitted. Then the JRL-2000F returns to receive state and K1 of the antenna switch unit is switched. The JRL-2000F returns again to transmit state and changes SELBK signal to Low level. The LOAD signal of the impedance detected by the impedance detector of the CFG-111 matching circuit is checked and the relay state is changed by one bit. Then TUNE signal of the impedance phase is checked and the relay state is changed again by one bit. Again the LOAD signal is checked and the relay state is changed by one bit. The state where the LOAD and TUNE signals are reversed is searched for by repeating these procedures. If the SWR value of the impedance detector circuit is less than 1.1, the automatic tuning is thought to be completed. During automatic tuning, the 7-segment LED is shown as in Fig.10 and the sound of when relays are switching is heard. Also during automatic tuning, the divided signal level is checked at times and "Po" is displayed when the input power is too small and "A6" when it is too large, as is the same in the SET operation, and automatic tuning is stopped temporarily. When the automatic tuning is completed, the data is written to EEPROM. The 7-segment LED on the front panel is shown as in Fig.11 for an instant, and then the frequency is displayed. If the automatic tuning has failed, "A7" is displayed.

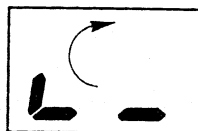

Fig.10



Fig.11

2.8 CML-334 Display

The CML-334 display is attached to the back of the front panel and is equipped with 2-digit 7-segment LED which displays the frequency, a LED which indicate transmit state, photosensor for the infrared remote control signal and other peripheral circuits. The LED DATA and SCAN signals light CD1 dynamically. The LED DATA and SCAN signals are also sent to the CSD-387 switch panel. TR1 to TR4 are drivers which provide 5 V to light LED.

R11 and R12 are resistors which limit the current of the LED DATA signal.

IC1 is a driver with open-collector output.

CD2 is a photosensor for the infrared remote control signal and the output is TTL level. The output signal is processed by the CDJ-1143 control CPU.

TR5 and TR6 are drivers which provide 5 V to light LED on the CSD-387 switch panel.

2.9 CSD-387 Switch Panel

The CSD-387 switch panel is attached to the back of the front panel and consists of 13 switches and 15 LEDs.

The LED DATA and SCAN signals light CD1 to CD9 and CD12 to CD16 dynamically. CD11 lights up statically.

The states of S1 to S13 are read by SCAN and SW DATA signals. The signals read are processed by the CDJ-1143 control CPU.

3. Troubleshooting

One of A1 to A9 (alphanumeric) is displayed on the front panel when the JRL-2000F issues an alarm. These displays are helpful when troubleshooting. The trouble can be caused by exciter, antenna or wraparound, etc. even if the JRL-2000F issues an alarm. Troubleshooting procedures, based on alarm information, will be described in this chapter.

- ◆ Troubleshooting procedures based on alarm information
 - ▶ When A1 or A2 (power supply failure) is displayed:

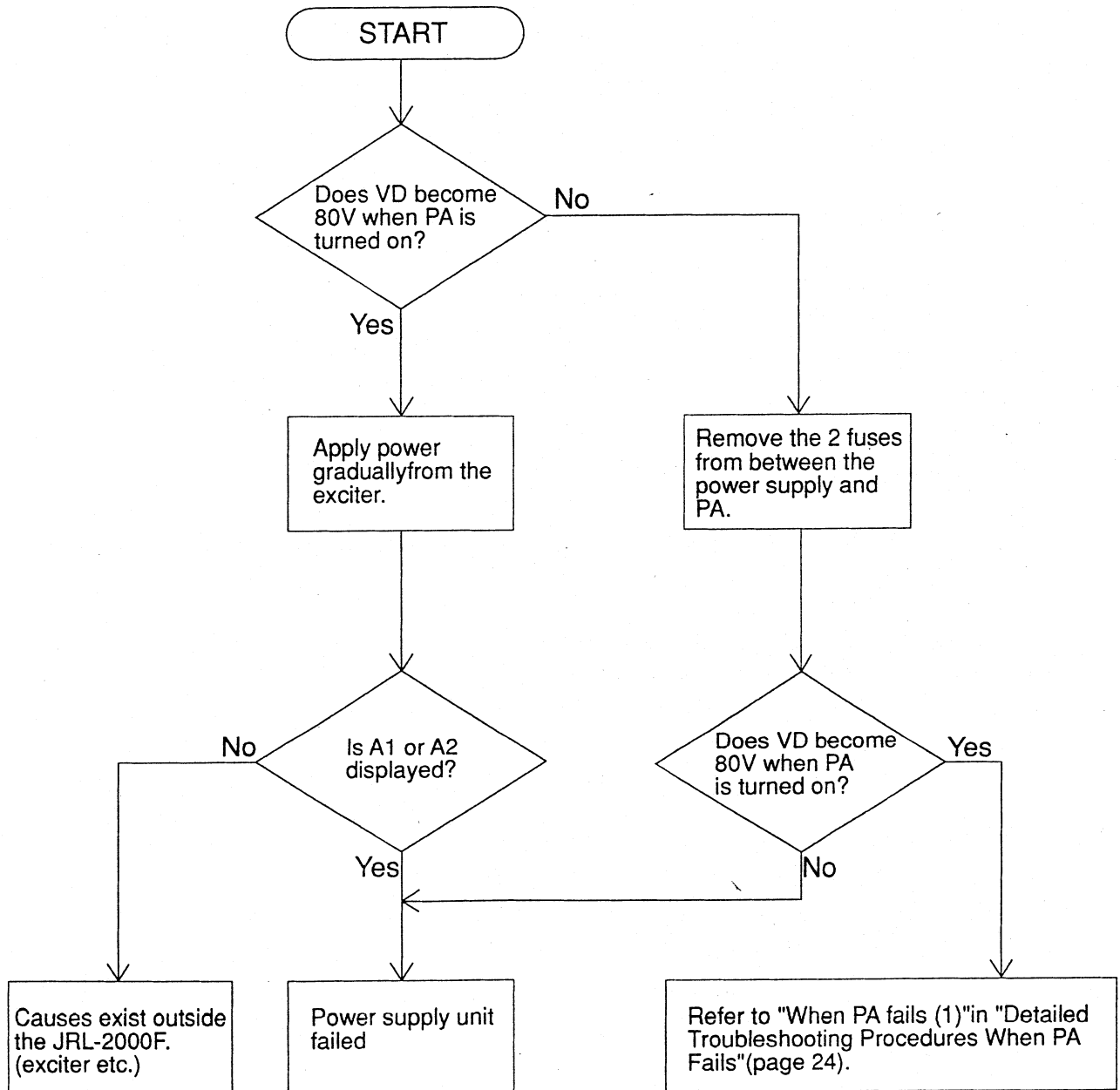

► When A3 (PA overheat) is displayed:

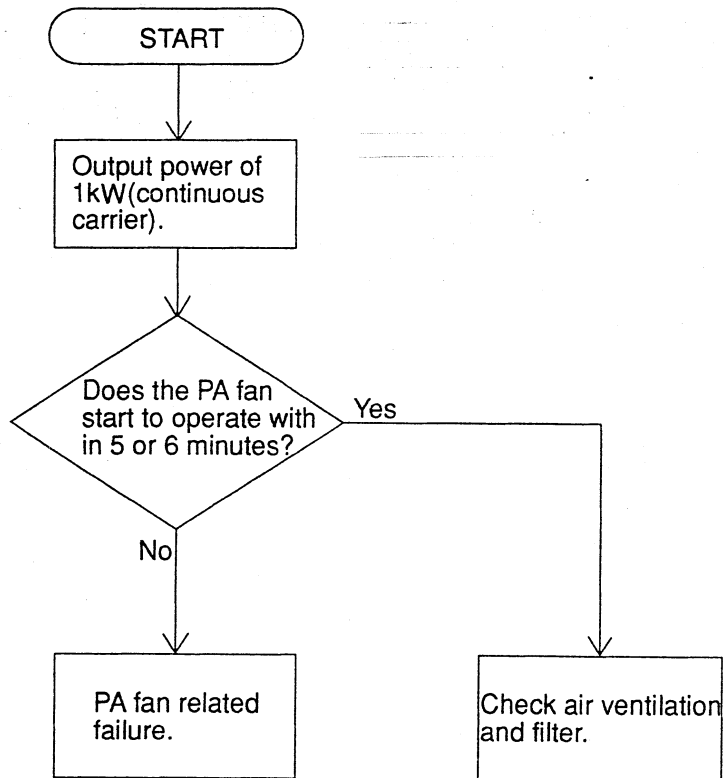

► When A4 (PA unbalanced) is displayed:
PA may be out of order.

Refer to "When PA fails (2)" in "Detailed Troubleshooting Procedures When PA Fails" (page 25)

► When A8 (antenna SWR) is displayed:

(1) When trouble is caused by detector circuit failure,
one of the following units may be out of order:

- a) CFG-111 matching circuit
- b) CDJ-1143 control

(2) When the actual reflected power is large,
one of the following units may be out of order:

- a) CSC-433 antenna switch
- b) CFG-111 matching circuit

► When A9 (load alarm) is displayed:

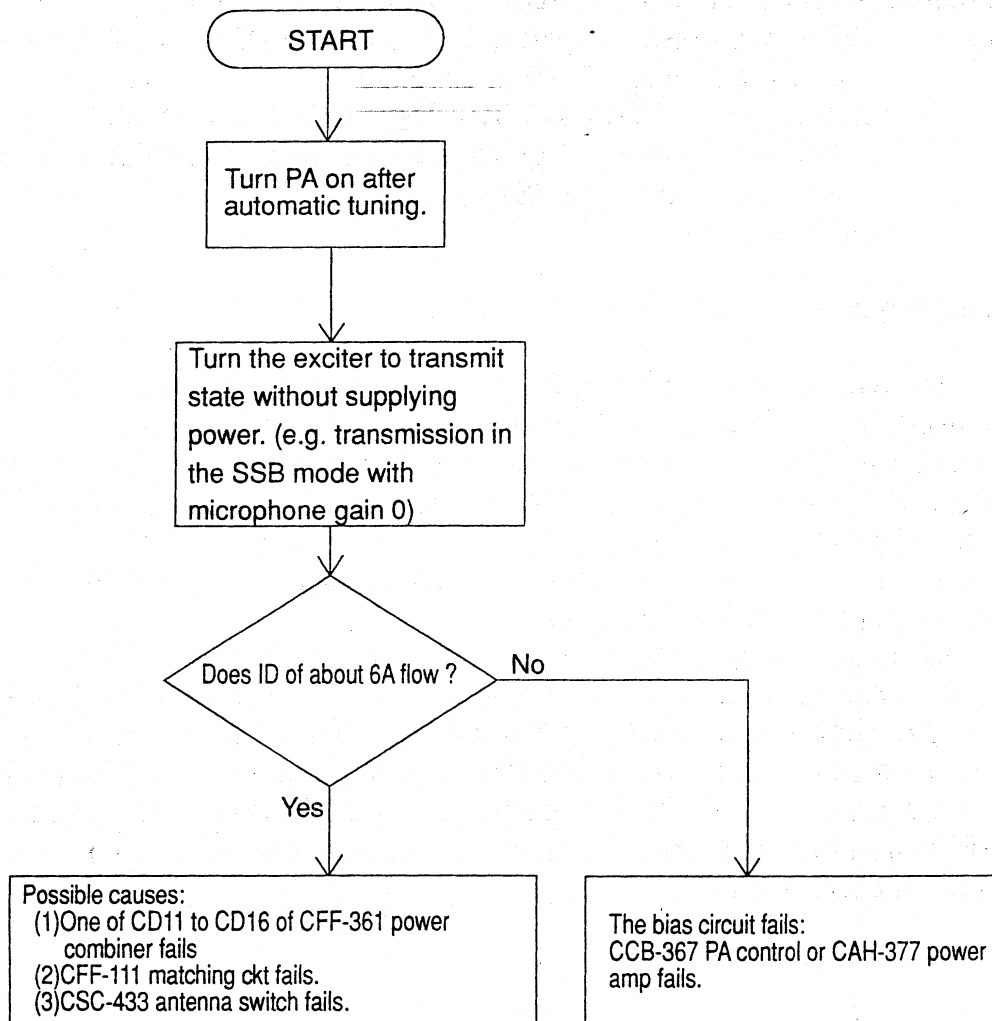

A9 alarm may be displayed when the congenial interface is poor with the exciter. Particularly be careful if it is displayed when the JRL-2000F is turned to transmission. (For details, refer to "Supplement" in the instructions manual.)

◆ Detailed Troubleshooting Procedures When PA Fails:

▶ When PA fails (1)

Phenomena: Short circuit between VDD of PA and the ground.

Causes : (1) One of bypass capacitors C14 to C19 or C24 to C29 of CAH-377 power amplifier has short-circuited.

(2) One of FETs TR11 to TR16, TR21 to TR26, TR31 to TR36 or TR41 to TR46 of CAH-377 power amplifier has short-circuited between drain (D) and source (S).

(3) Others

< Troubleshooting procedures >

- (1) Remove the two fuses (15 A each) from between the PA unit and power supply unit.
- (2) Check two CAH-377 power amplifiers for the electric conductivity between VDD and the ground with a tester to find which one is out of order. In the normal state, the electric conductivity between VDD and the ground shows diode characteristics (cathode: VDD, anode: ground).
- (3) Check the external appearance of the bypass capacitors or FETs of the failed CAH-377 power amplifier for damage, etc.
- (4) In the case of a short circuit between drain (D) and source (S) of FET, check the resistance value between gate (G) and source (S) to locate the failed FET because in most cases between gate (G) and source (S) has short-circuited. As shown in Fig. 12, in the case of a short-circuit between gate (G) and source (S), the resistance value between gate (G) and source (S) of each TR12 to TR16 is about 54Ω . If all FETs are normal, the resistance value between gate (G) and source (S) of each FET is about $10 \text{ k}\Omega$.

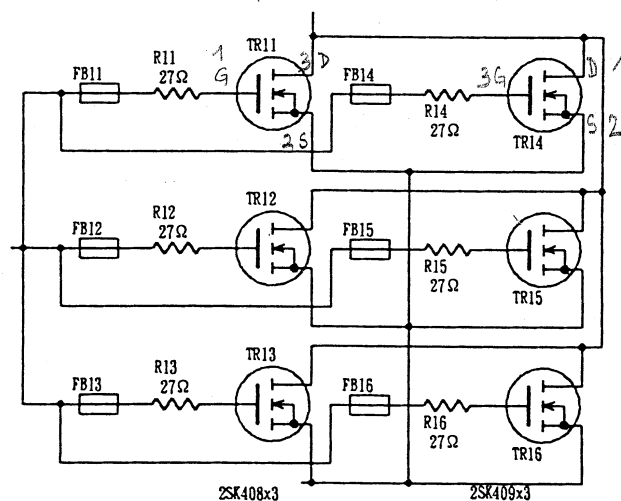

Fig.12

▶ When PA fails (2):

Phenomena: The input side of PA is grounded for high frequencies.

Causes : (1) One of FETs of CAH-377 has short-circuited.

(2) One of input transformers of CAH-377 has short-circuited or been broken.

(3) Others

< Troubleshooting procedures >

- (1) Make PA generate power by itself if possible, and check for the heat generated by the resistors of the combiner to find which PA unit is out of order.
- (2) Check the external appearance of FETs of CAH-377 power amplifier for damage, etc.
- (3) As shown in Fig. 12, in the case of a short-circuit between gate (G) and source (S), the resistance value between gate (G) and source (S) of each TR12 to TR16 is about 54Ω : If all FETs are normal, the resistance value between gate (G) and source (S) of each FET is about $10 \text{ k}\Omega$.
- (4) If all FETs are normal, check for a short circuit or breakage in the transformers. To compensate the external observation, turn the power on and compare the waveforms of each part.

4. Confirmation of Operation and Readjustment

4.1 Outline

When an FET is replaced in the PA unit, "4.2.2 Adjustment of Idling Current" is required.

When the PA unit is replaced, "4.4.2 Adjustment of APC Circuit" and "4.4.3 Adjustment of ALC Circuit" is required.

When the power supply unit is replaced, "4.3.1 Adjustment of Output Voltage" and "4.4.1 Adjustment of Meters" is required.

4.2 Adjustment of 2 PA Units

All adjustable parts of the PA unit are in the CCB-367 PA control circuits.

4.2.1 Adjustment of Heat Sensor

[Required instruments]

- (1) Digital tester
- (2) Thermometer

< Adjustment procedures >

(1) Measure TP1 voltage with a digital tester.

TP1 voltage: E_{TP1} 1400–1500mV

(2) Measure the room temperature (T_a).

(3) Calculate TP3 voltage to be adjusted with the following formula:

$$E_{TP3} = E_{TP1} - (75^\circ\text{C} - T_a) \times 4.5$$

[Example] Where $E_{TP1} = 1450$ mV and $T_a = 25^\circ\text{C}$,

$$E_{TP3} = 1450 - (75 - 25) \times 4.5 = 1450 - 220 = 1230 \text{ mV}$$

(4) Adjust RV1 to the calculated voltage while measuring TP3.

(5) Obtain E_{TP2} by measuring TP2 voltage.

Using the same formula in step (2),(3)

$$E_{TP4} = E_{TP2} - (75^\circ\text{C} - T_a) \times 4.5$$

Adjust RV2 to the calculated voltage while measuring TP4.

(6) Confirm that the fan does not operate in this state.

4.2.2 Adjustment of Idling Current

[Required instruments]

(1)DC ammeter (10 A)

< Adjustment procedures >

- (1) Check + and – terminal of PA with a tester.
- (2) Arrange a DC ammeter between the power supply unit and PA unit as shown in Fig.13.(Set the range of ammeter to 10 A.)
- (3) Turn all the volume switches, RV11 to RV14 and RV21 to RV24 of CCB-367 PA control bias, anticlockwise until they stop.
- (4) Turn on PA and apply an 80 V voltage. Confirm that the current is 0 A.
- (5) Turn the transceiver to transmit state without supplying power.(e.g. transmission in the SSB mode with microphone gain 0)Confirm that the current is 0 A.
- (6) Turn RV11 clockwise to adjust the DC ammeter to 0.8 A.
- (7) Turn RV12 clockwise to adjust the DC ammeter to 1.6 A.
- (8) Turn RV13 clockwise to adjust the DC ammeter to 2.4 A.
- (9) Turn RV14 clockwise to adjust the DC ammeter to 3.2 A.
- (10)Turn RV21 clockwise to adjust the DC ammeter to 4.0 A.
- (11)Turn RV22 clockwise to adjust the DC ammeter to 4.8 A.
- (12)Turn RV23 clockwise to adjust the DC ammeter to 5.6 A.
- (13)Turn RV24 clockwise to adjust the DC ammeter to 6.4 A.

(The adjusting order does not have to be consecutive from (6) to (13) as above. Adjust to flow a current of 0.8 A for a volume switch. The volume switch points in the direction of about one o'clock. If it does not point in that direction, a failure may exist.)

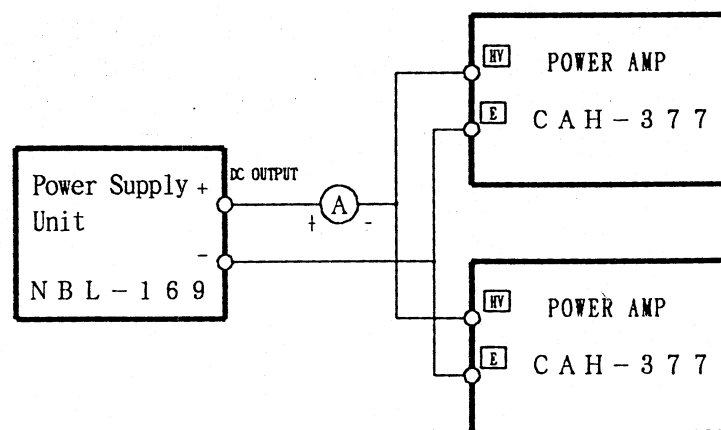

Fig.13.

4.3 Adjustment of Power Supply Unit

4.3.1 Adjustment of Output Voltage

[Required measuring instrument]

(1) Tester

< Adjustment procedures >

- (1) Install the power supply unit to the JRL-2000F and turn the power and PA on.
- (2) Remove the rubber cap from the rear panel of the JRL-2000F. Insert a minus screw driver until it hits the volume switch (RV201 of CBG-68 main PS unit). Turn the volume switch to adjust it to DC + 80 V while checking the voltage of the output terminal of PA with a tester.

4.4 Total Adjustment

Totally adjustable parts exist in CDJ-1143 control and CCB-367 PA control circuits.

4.4.1 Adjustment of Meter

[Required measuring instruments]

- (1) High frequency power meter (over 1 kW max.)
- (2) Dummy load (over 1 kW max.)

< Adjustment procedures >

- (1) Turn on the PA switch of the JRL-2000F. A yellow LED of PA lights up after approx. 0.6 second, and the pointer of the meter on the righthand side moves (VD range). Adjust RV4 of CDJ-1143 control circuit so that the meter indicates 80 V.
- (2) Output power from the exciter. Adjust so that the external power meter (not the meter on the righthand side of the JRL-2000F.) points to 1000 W and then adjust RV3 so that the meter (range is Po) on the lefthand side of the JRL-2000F points to 1000W.

4.4.2 Adjustment of APC Circuit

[Required measuring instruments]

- (1) High frequency power meter (over 1 kW max.)
- (2) Dummy load (over 1 kW max.)

< Adjustment procedures >

- (1) Turn RV3 of CCB-367 PA control anticlockwise until it stops.
- (2) Set the output power to 1050 W. Adjust RV3 APC to decrease the power a little.
- (3) Confirm that a drive LED lights up orange in color when the level of the output power of the transceiver is slightly increased.

4.4.3 Adjustment of ALC Circuit

[Required measuring instruments]

- (1) High frequency power meter (over 1 kW max.)
- (2) Dummy load (over 1 kW max.)

< Adjustment procedures >

- (1) Turn ALC volume switch on the back of the JRL-2000F anticlockwise, viewing from the front, until it stops.
- (2) Adjust the frequency to 21 MHz and power to 1000 W.
- (3) Switch the right meter range to ALC and adjust RV1 of CDJ-1143 control circuit. Turn RV1 until the needle of the meter suddenly moves. Adjust RV1 so that the needle of the meter exceeds a little further from the white zone.
- (4) Turn ALC volume switch on the back of the JRL-2000F anticlockwise, viewing from the front, so that the needle of the meter moves backward from the white zone. At this time, the output power becomes about 950 W.
- (5) Turn ALC volume switch on the back of the JRL-2000F anticlockwise, viewing from the front, until it stops.

4.4.4 Adjustment of the VSWR Meter

- (1) Switch the meter range to VSWR in receive state and adjust RV5 of CDJ-1143 control circuit so that the needle of the meter points to zero.

5. External View

5.1 Front Panel -----	31
5.2 Rear Panel -----	31
5.3 Side Panel -----	31
5.4 Bottom Panel -----	31
5.5 When the Upper Cover is Opened -----	32
5.6 When the Lower Cover is Opened -----	32

5.1 Front Panel

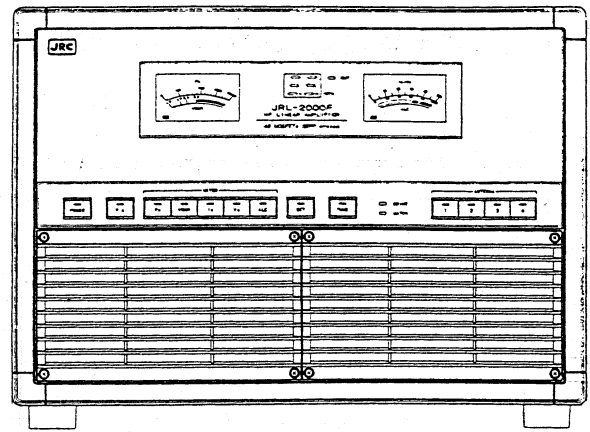

5.2 Rear Panel

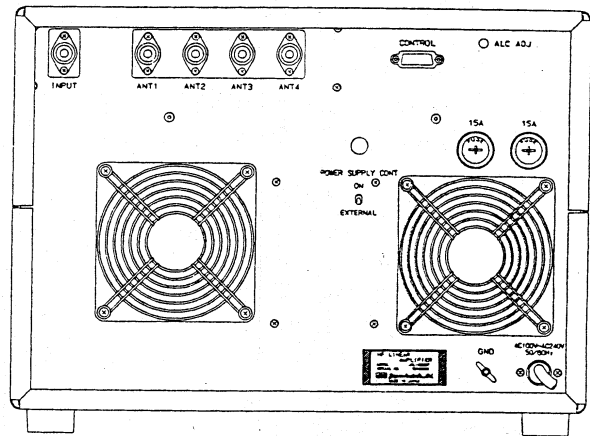

5.3 Side Panel

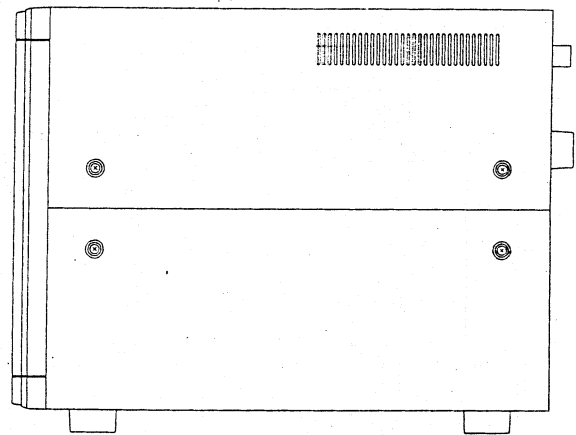

5.4 Bottom Panel

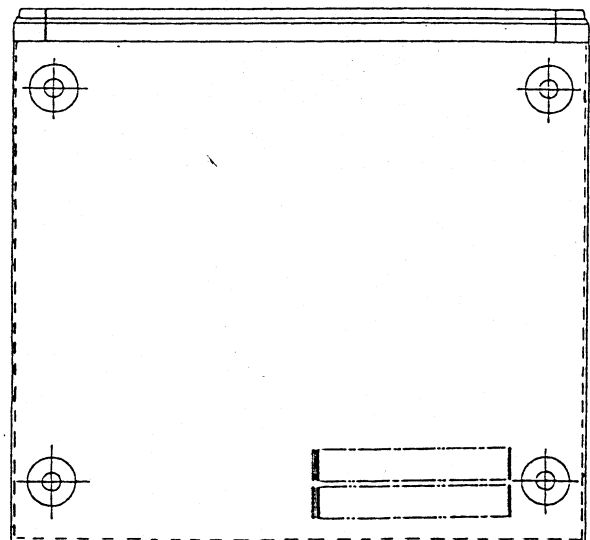

5.5 When the Upper Cover is Opened

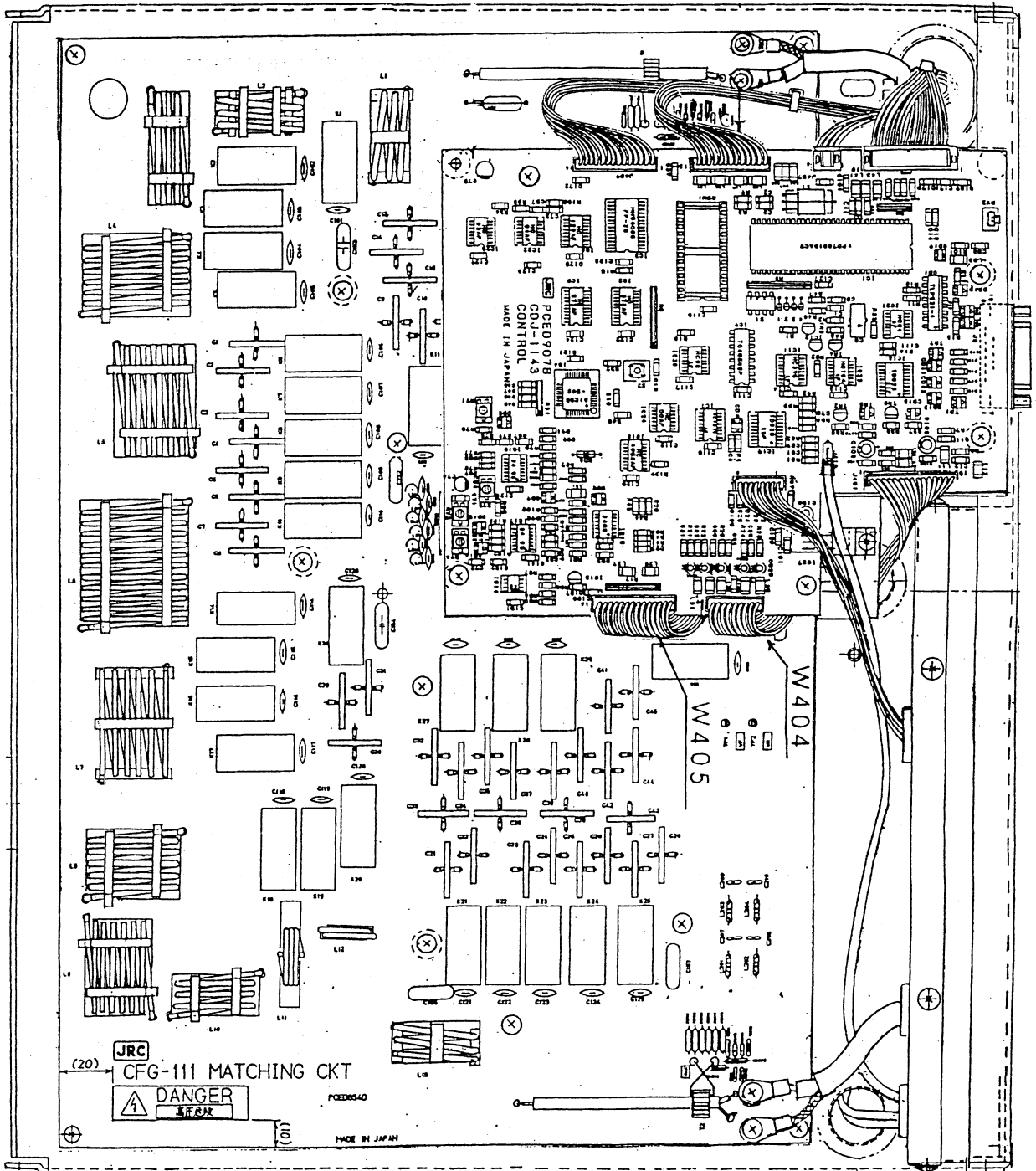

5.6 When the Lower Cover is Opened

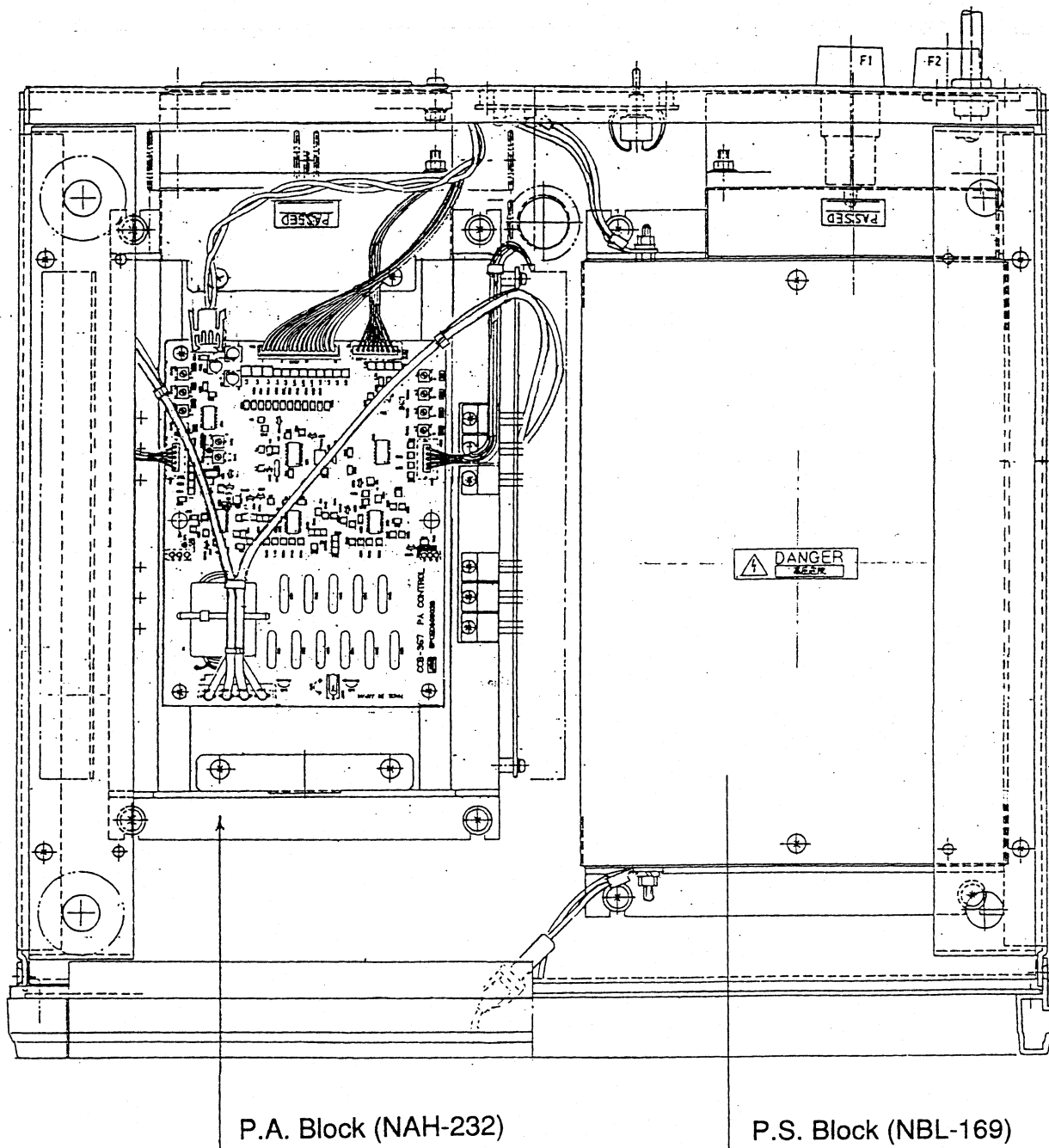

6. Block Diagram

6.1 Block Diagram -----35

6.2 Interconnection Diagram -----36

6.1 Block Diagram

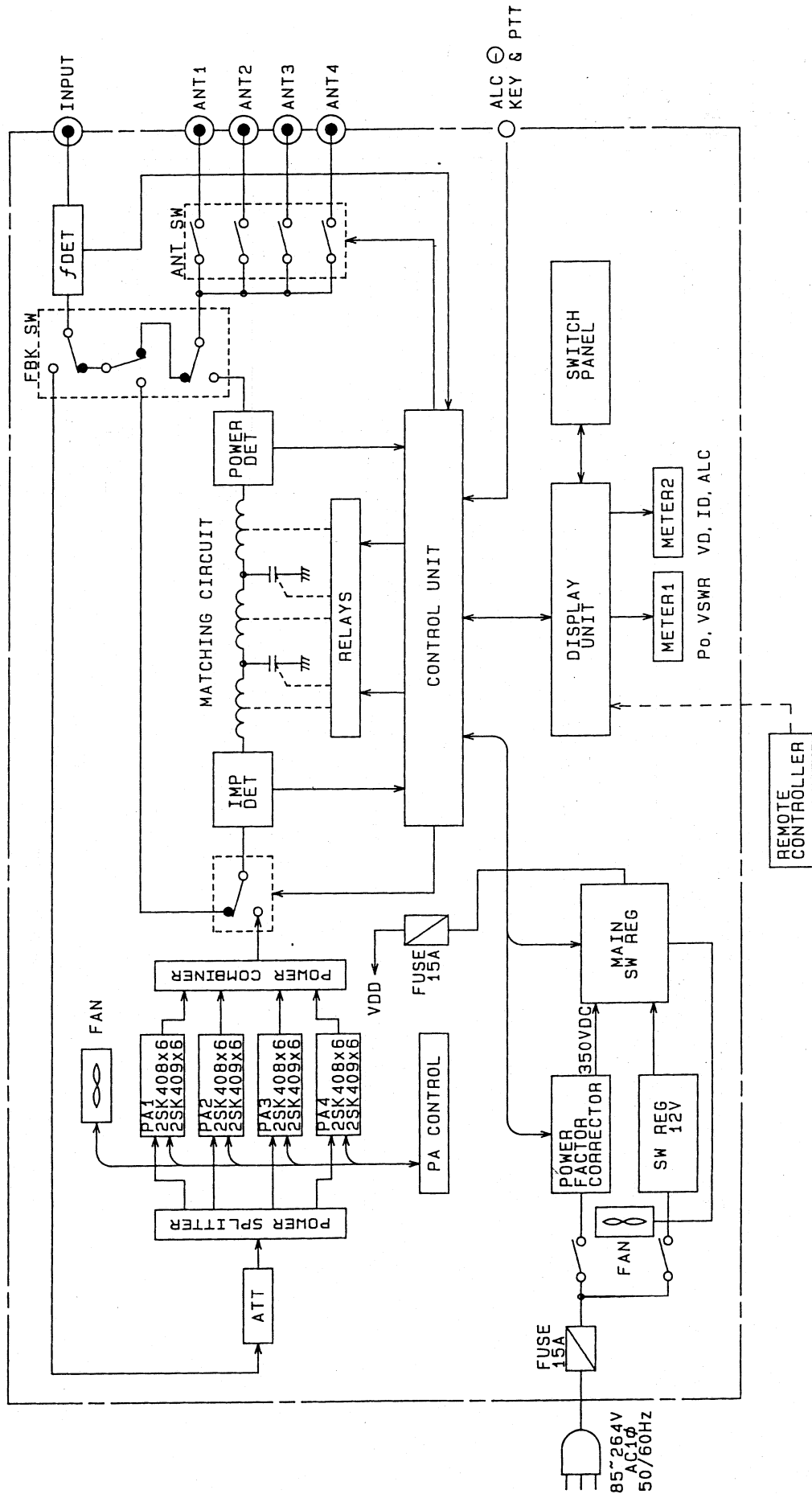

6.2 Interconnection Diagram

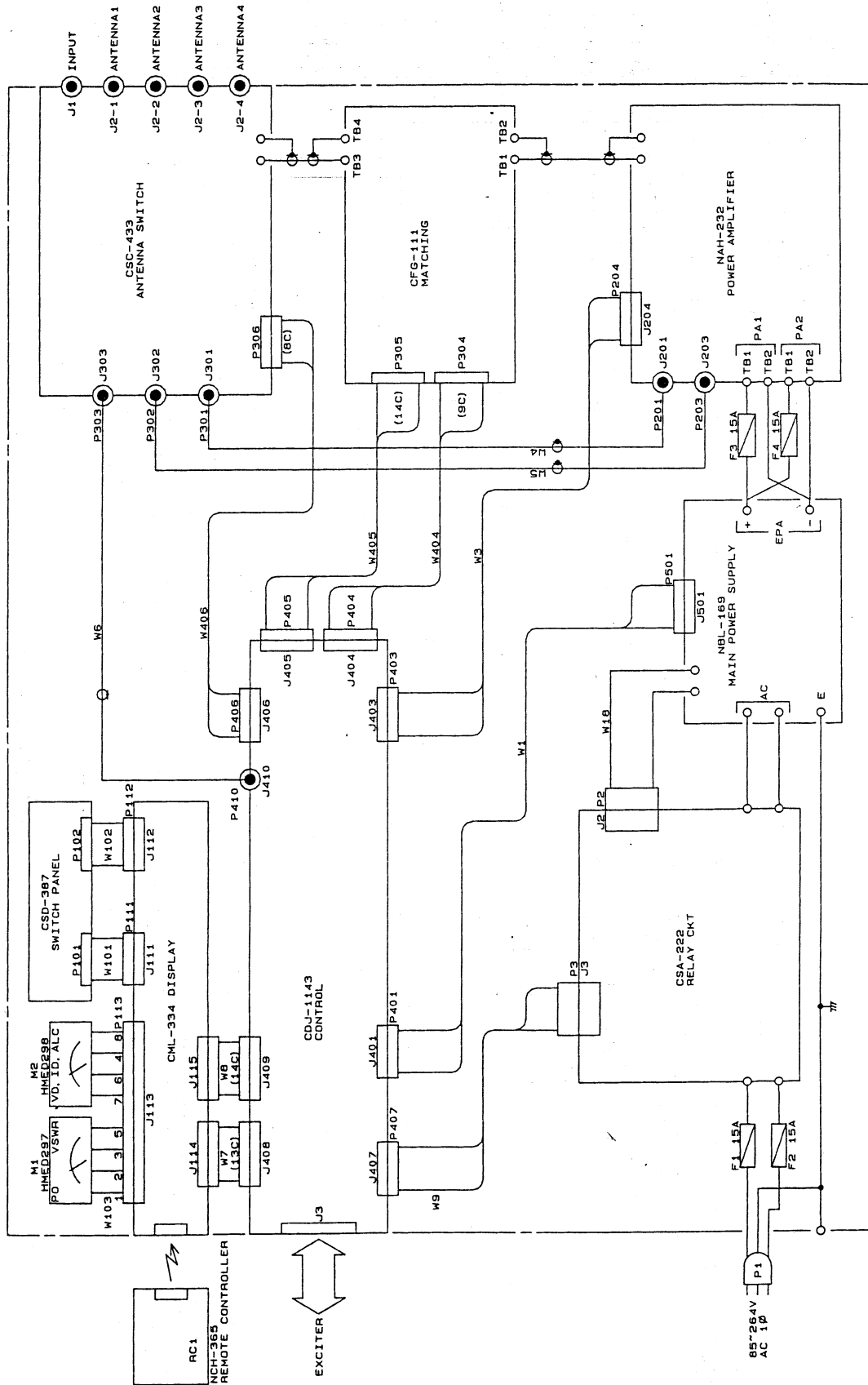

7. Connection Diagram

7.1 NAH-232 Power Amplifier Unit -----	38
7.1.1 CAH-377 Power Amplifier -----	39
7.1.2 CCB-367 PA Control -----	40
7.1.3 CFF-361 Power Combiner -----	41
7.2 NBL-169 Power Supply Unit -----	42
7.2.1 CSA-222 Relay Circuit -----	43
7.2.2 CBB-13 Power Factor Corrector -----	44
7.2.3 CBG-68 Main PS Unit -----	45
7.2.4 CFR-102 Noise Filter -----	46
7.3 CFG-111 Matching Circuit -----	47
7.4 CSC-433 Antenna Switch -----	50
7.5 CDJ-1143 Control -----	51
7.6 CML-334 Display -----	53
7.7 CSD-387 Switch Panel -----	54

7.1 NAH-232 Power Amplifier Unit

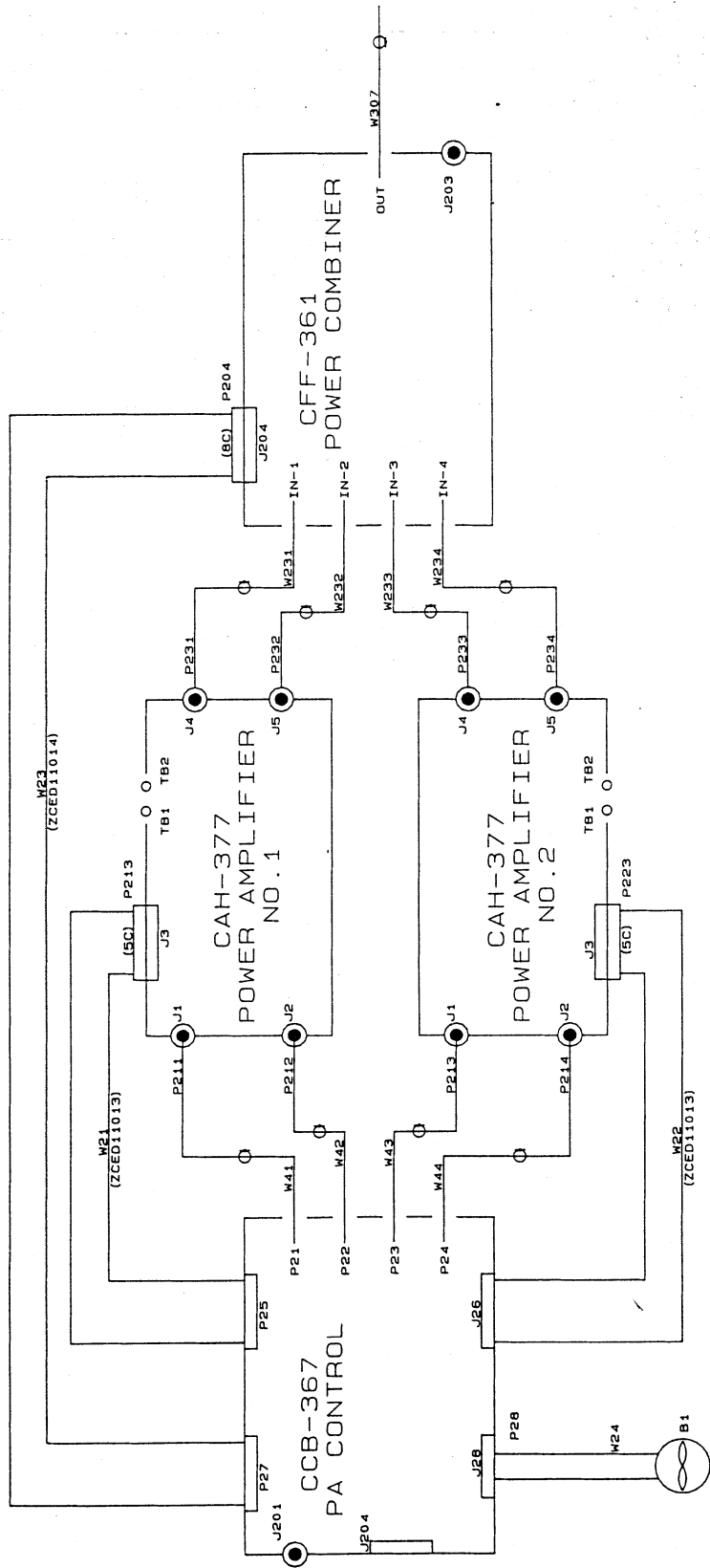

W41~W44 : 1.5D-2V (ZCED310)
W231~W234 : 2.5D-2V (ZCED311)
W307 : 5D-2V

7.1.1 CAH-377 Power Amplifier

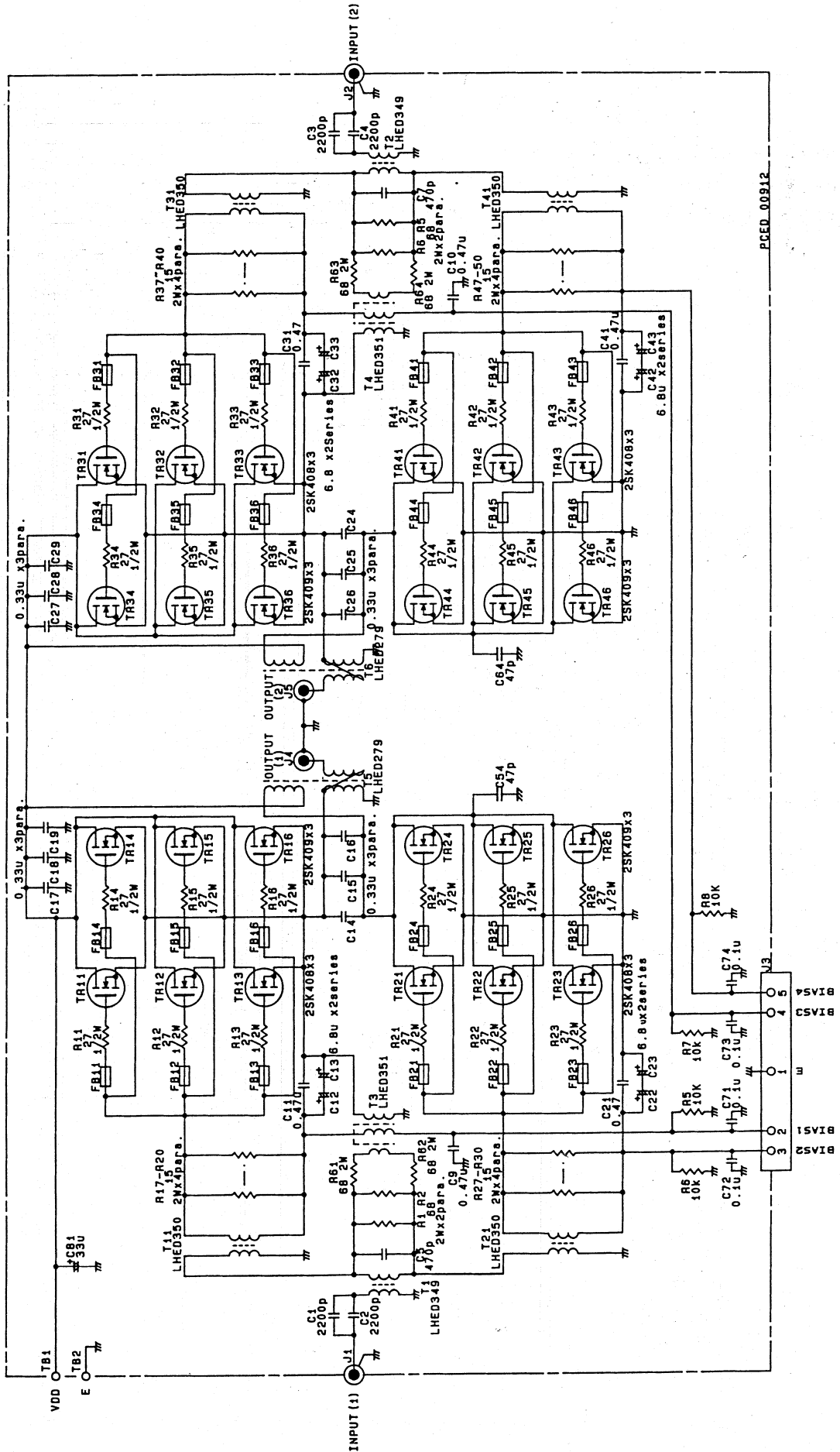

PCED_00912

7.1.2 CCB-367 PA Control

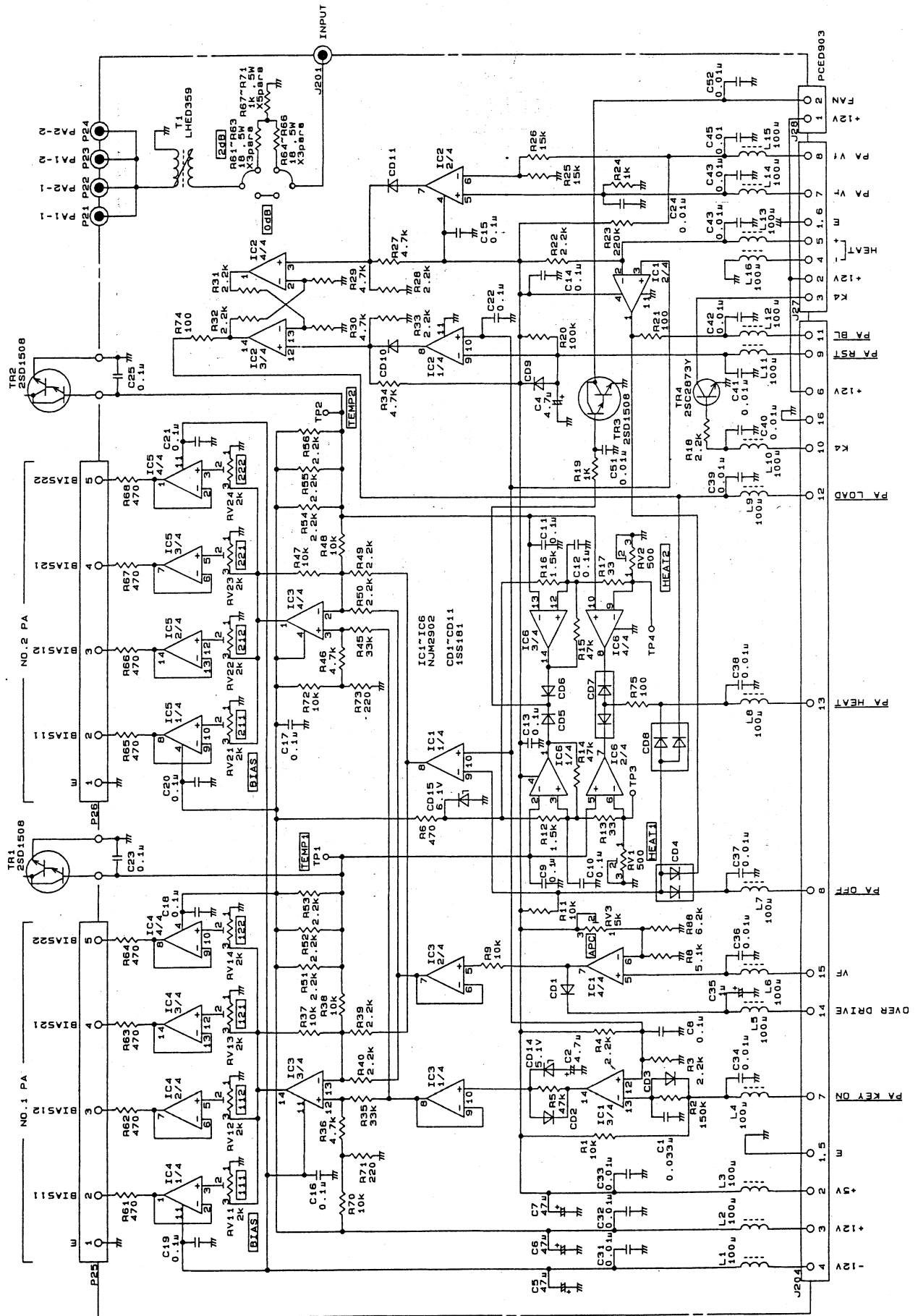

7.1.3 CFF-361 Power Combiner

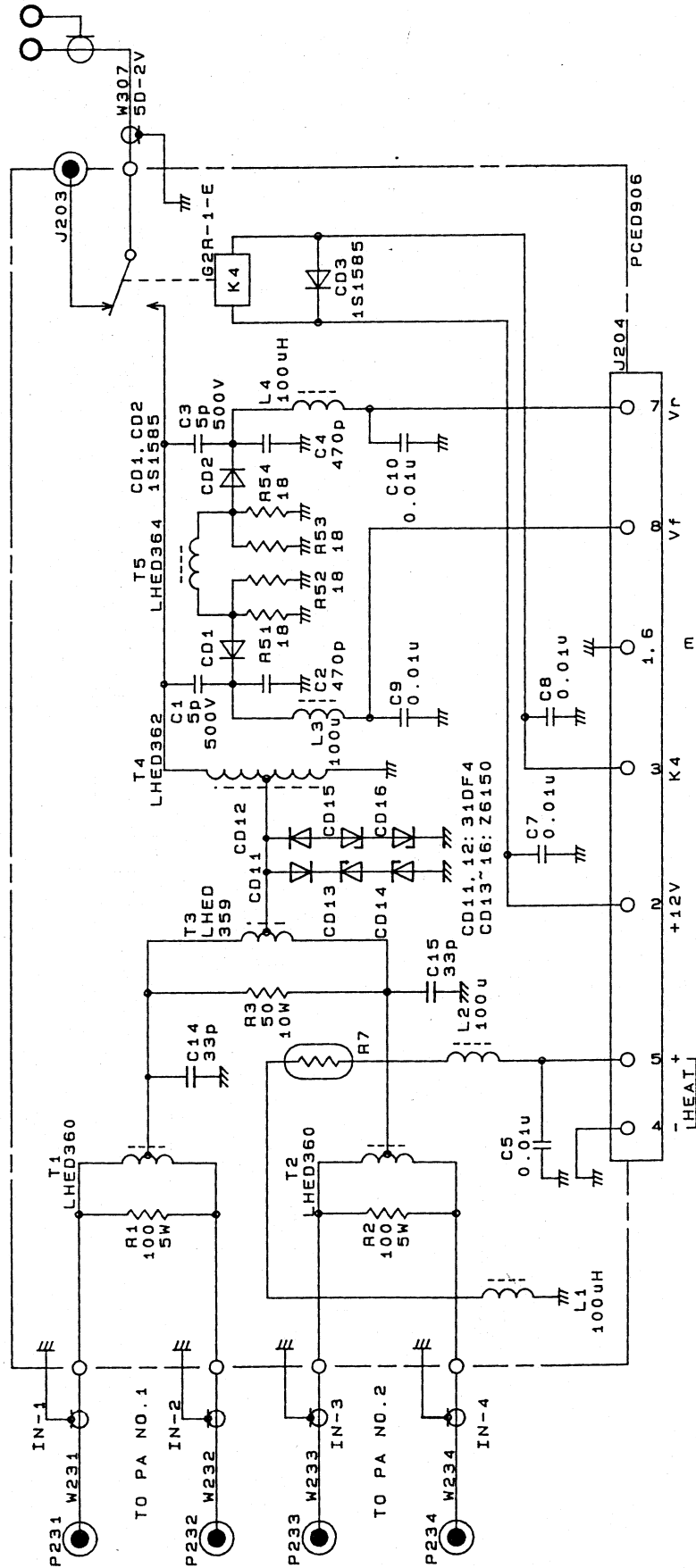

7.2 NBL-169 Power Supply Unit

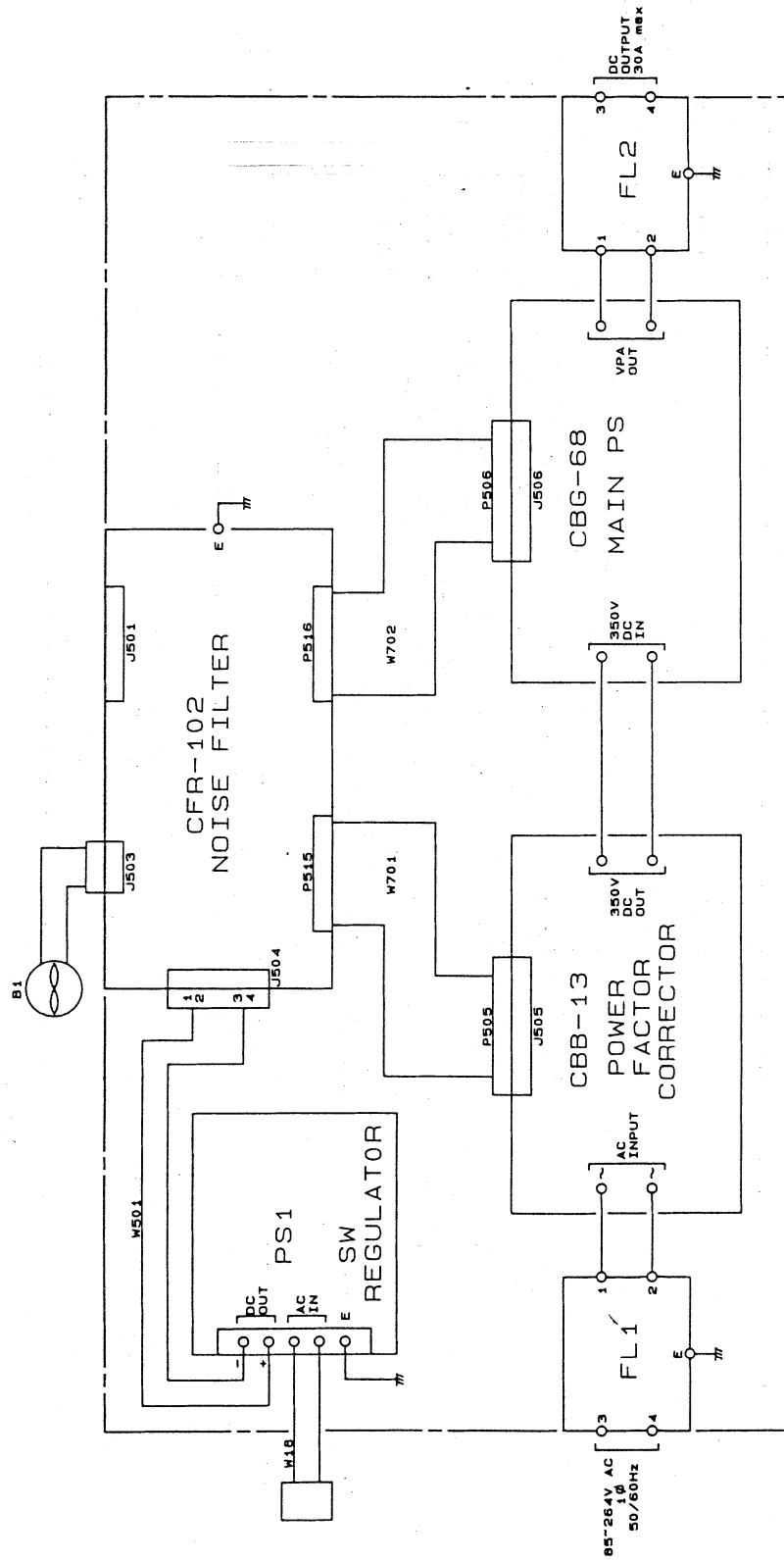

7.2.1 CSA-222 Relay Circuit

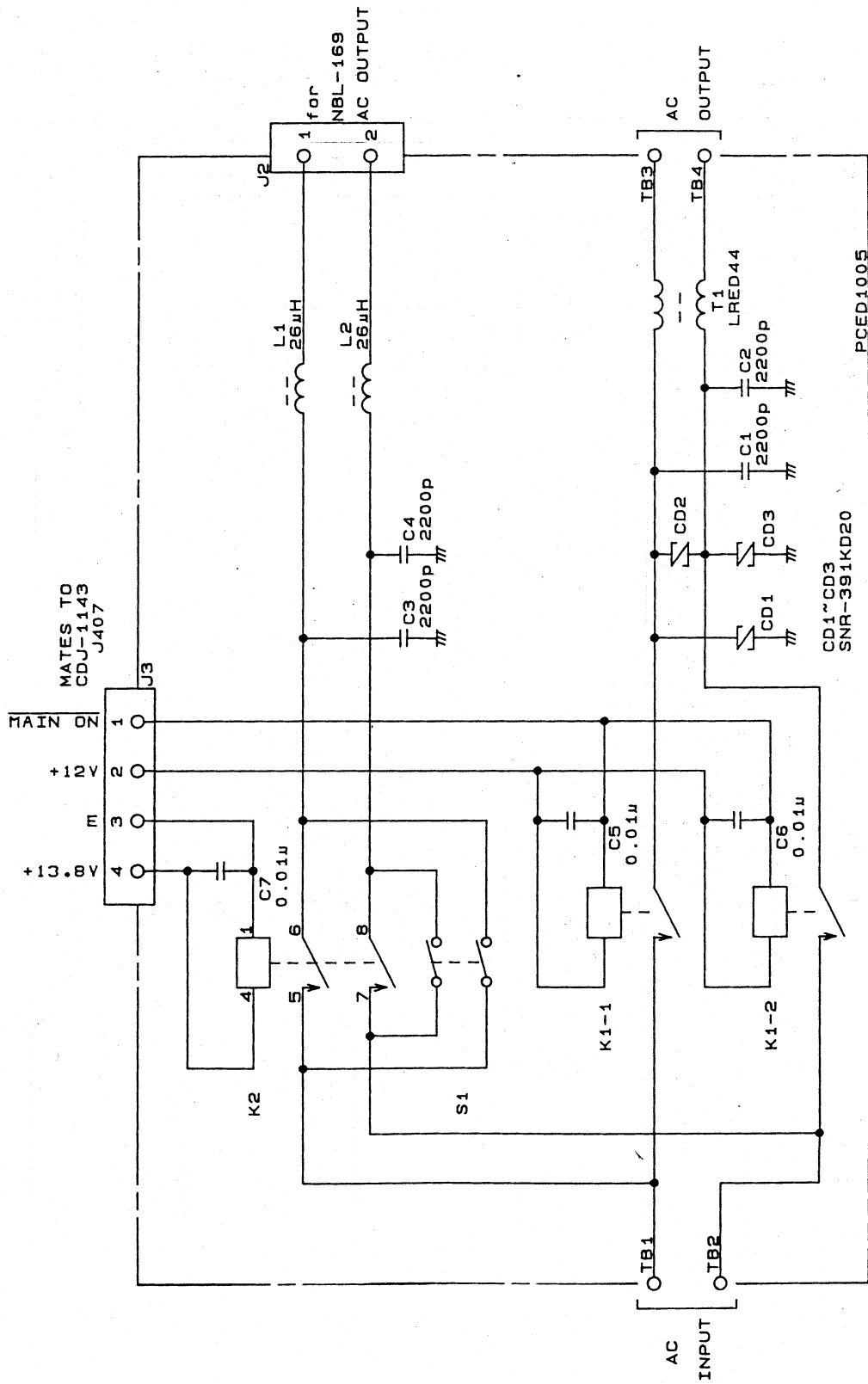

7.2.2 CBB-13 Power Factor Corrector

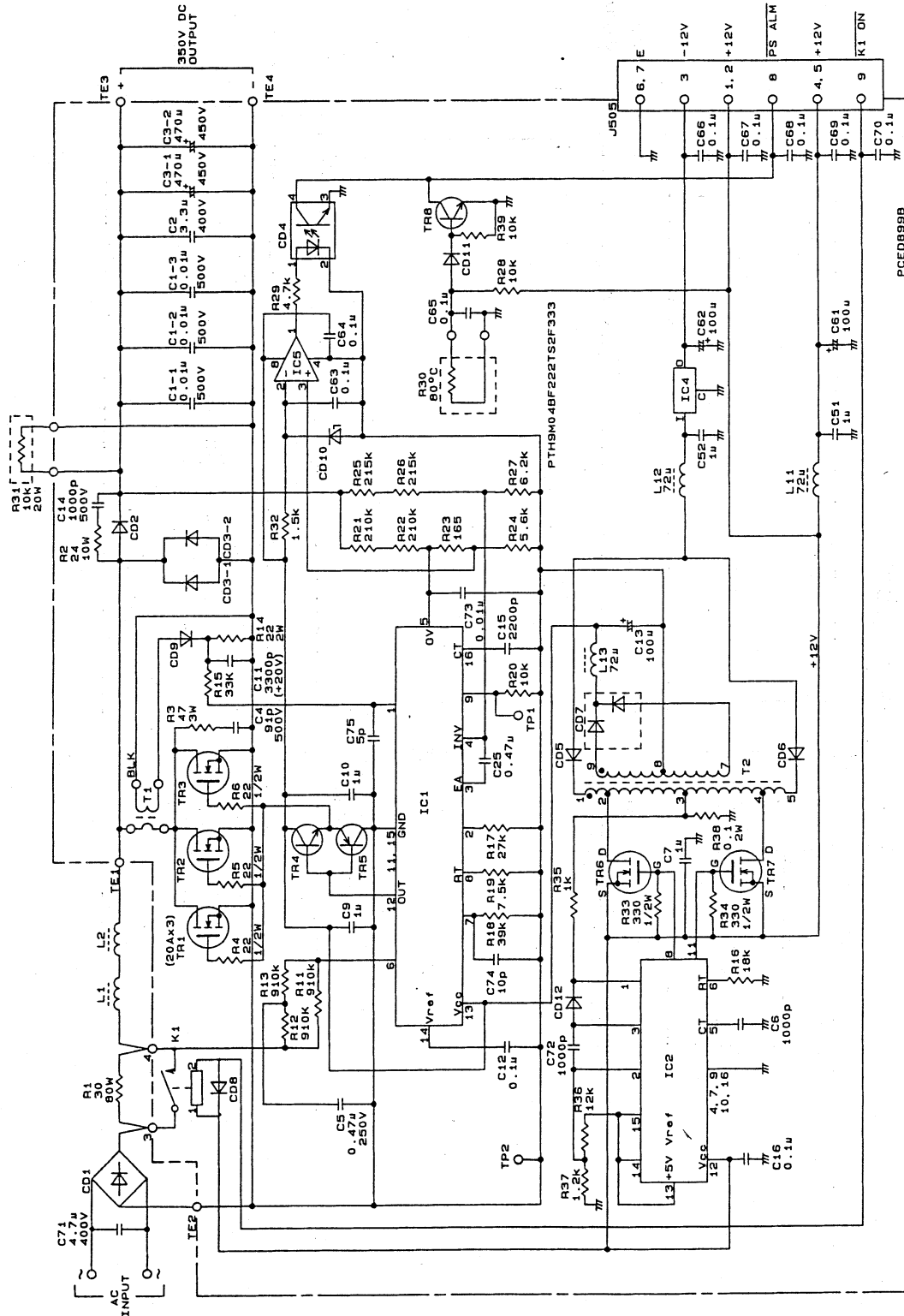

TR1-3	2SK1250	IC4	NJM7912FA	CD5, 6, 9	H114B
TR4, 6	2SC2655	IC5	NJM2904L	CD7	FMB26L
TR5	2SA1020	CD1	15G4B41	CD8, 11, 12	1S1588
TR6, 7	1RF9530	CD2	30KF508	CD10	HZ5C1
IC1	ML4812CP	CD3-1, 3-2	RG4C		
IC2	TL594CN	CD4	TLP521-1-A		

7.2.4 CFR-102 Noise Filter

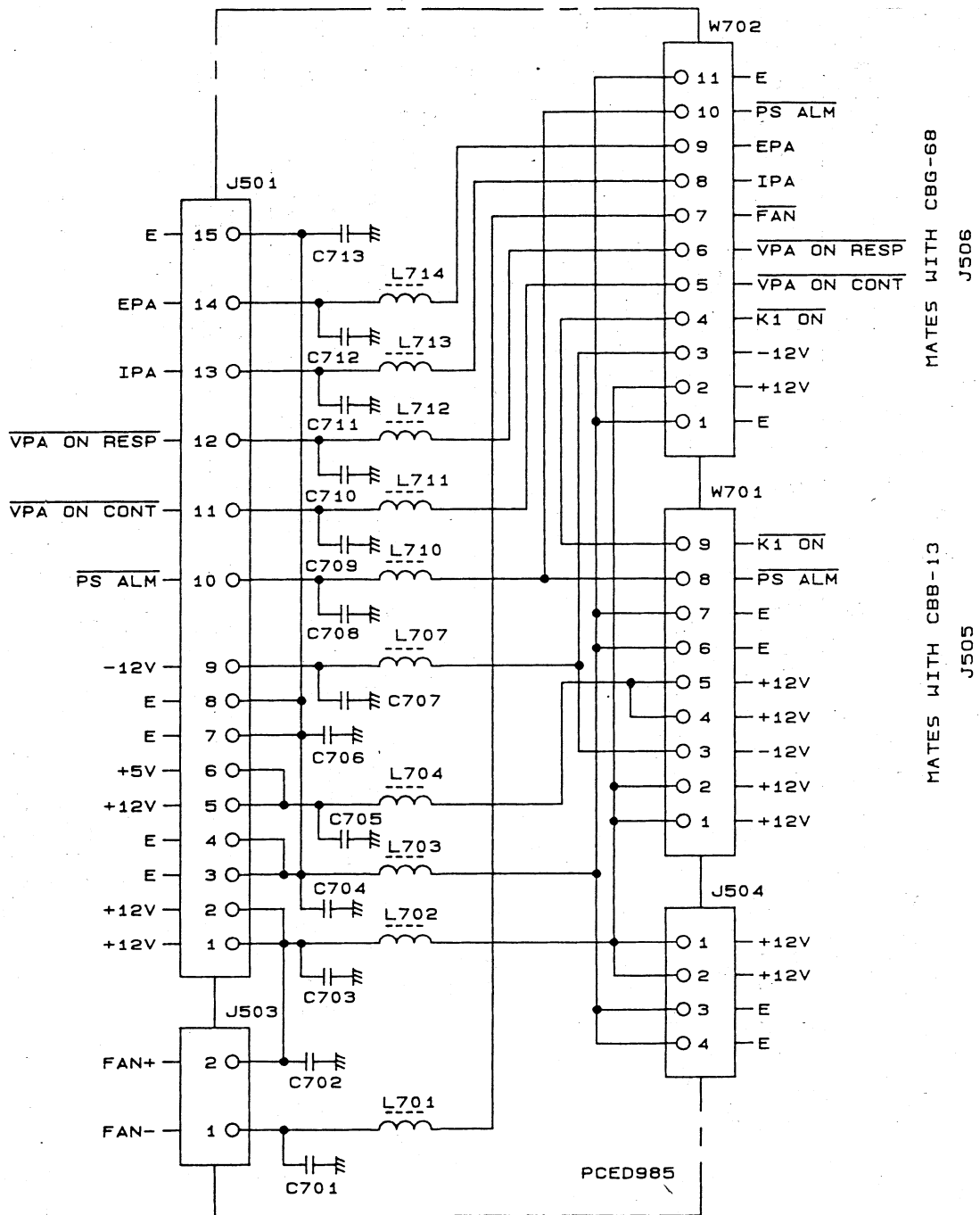

C701~714: 50V 0.1uF (RPE 132F104Z50)
 L701~704: 72uH (SF-T8-50S)
 L707~711: 100uH (LF85-101K)
 L712~714: 100uH (LAL04NA101K)

7.3 CFG-111 Matching Circuit

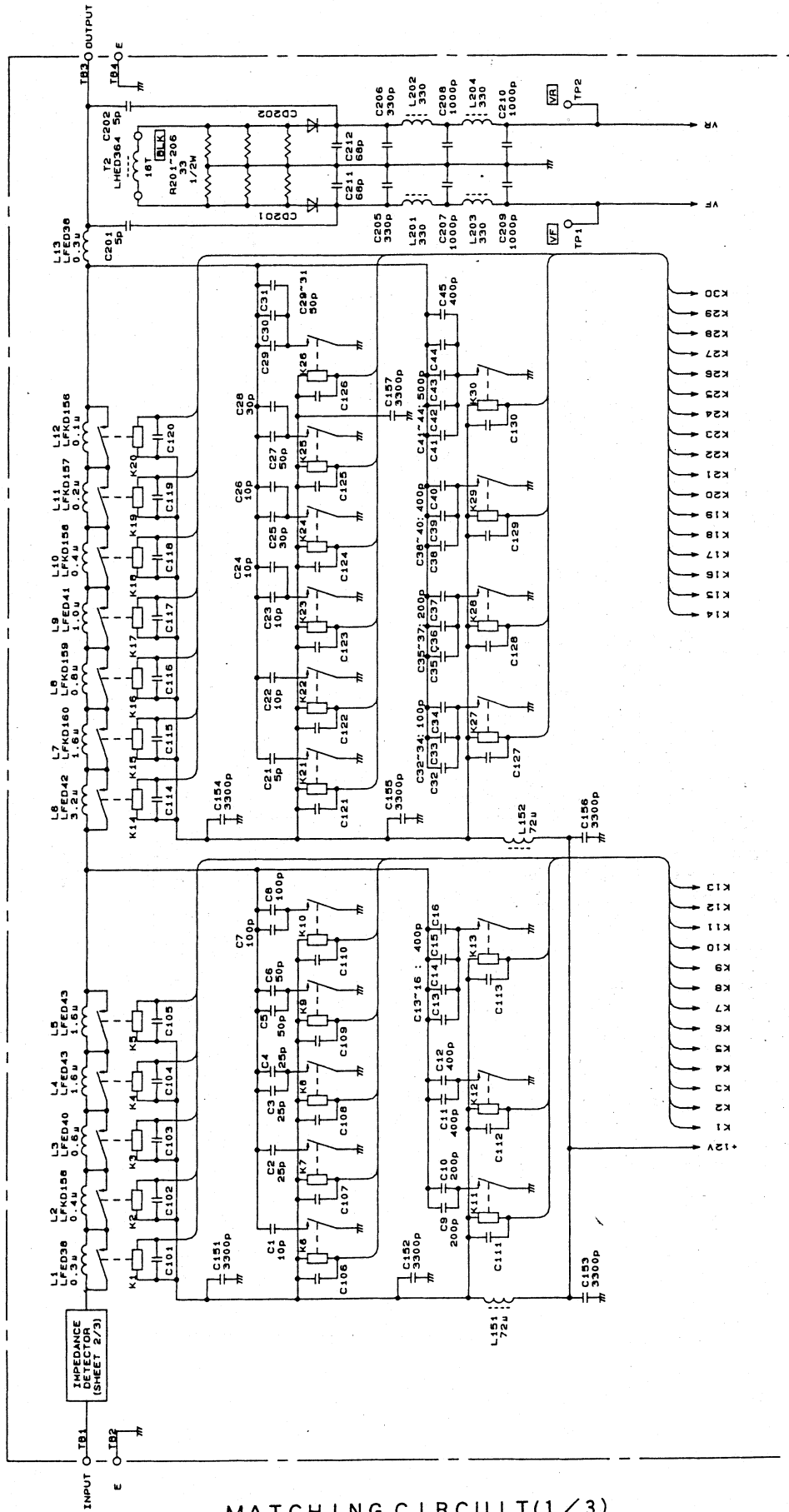

MATCHING CIRCUIT(1/3)

PCE054

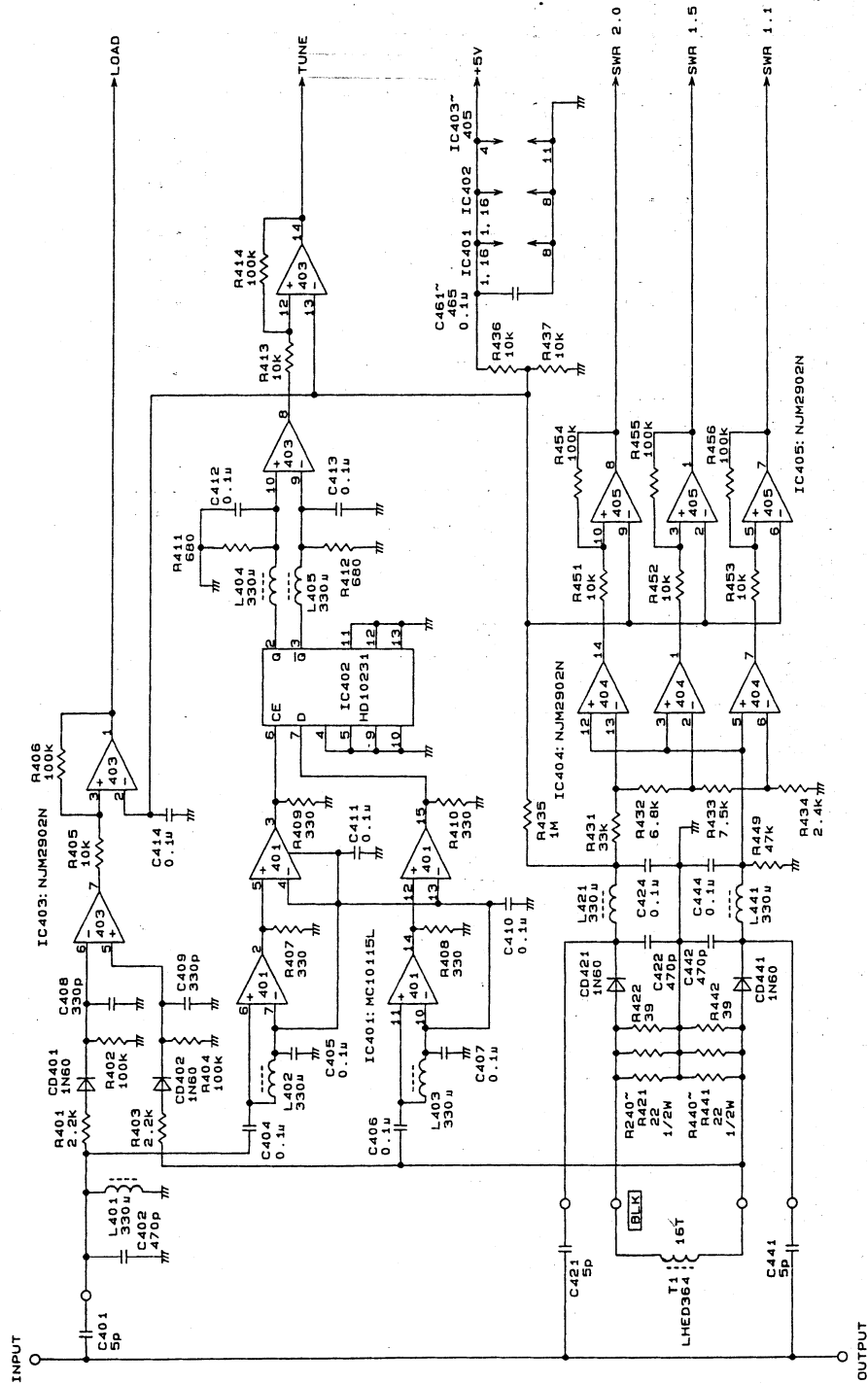

MATCHING CIRCUIT(2/3)

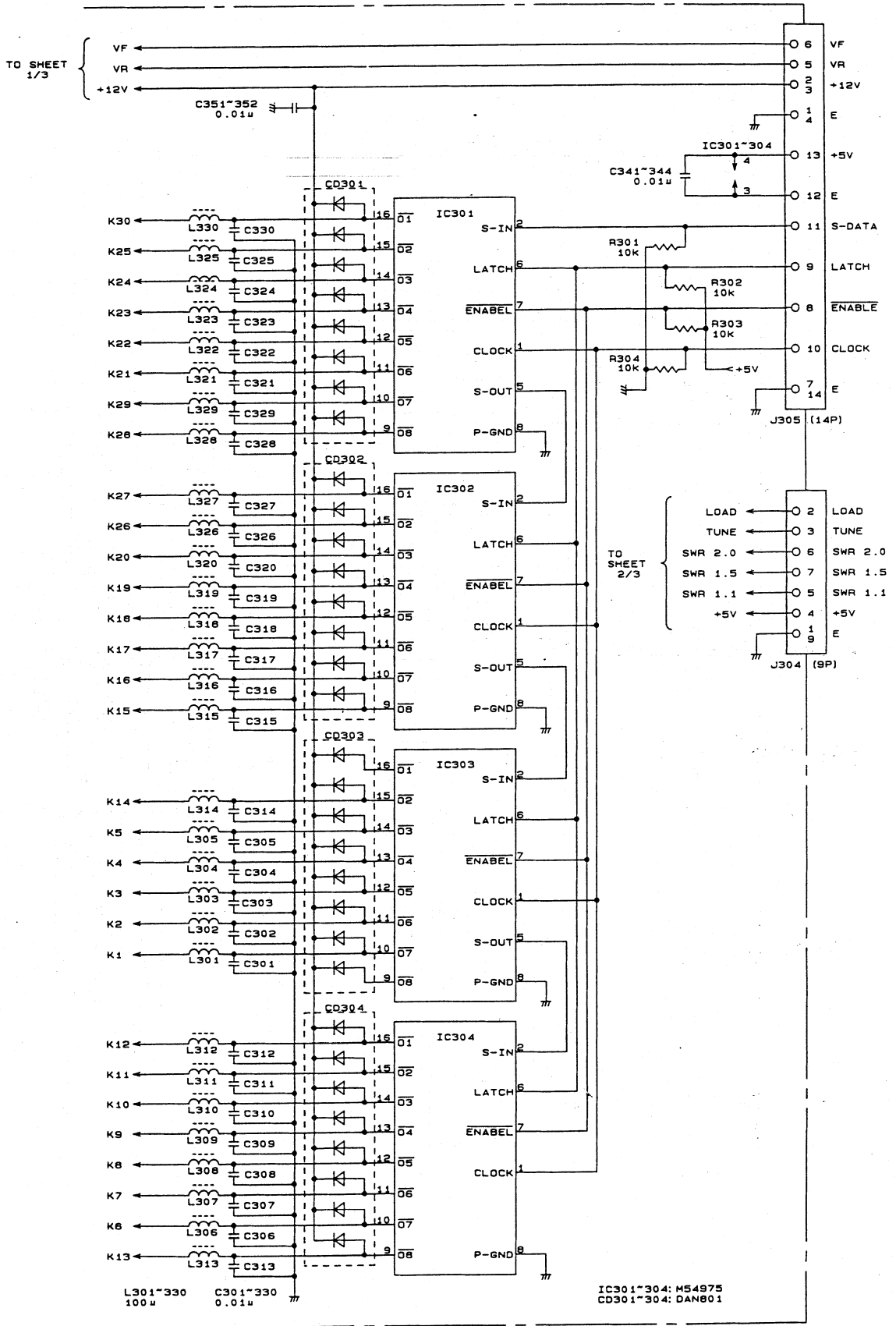

MATCHING CIRCUIT(3/3)

7.4 CSC-433 Antenna Switch

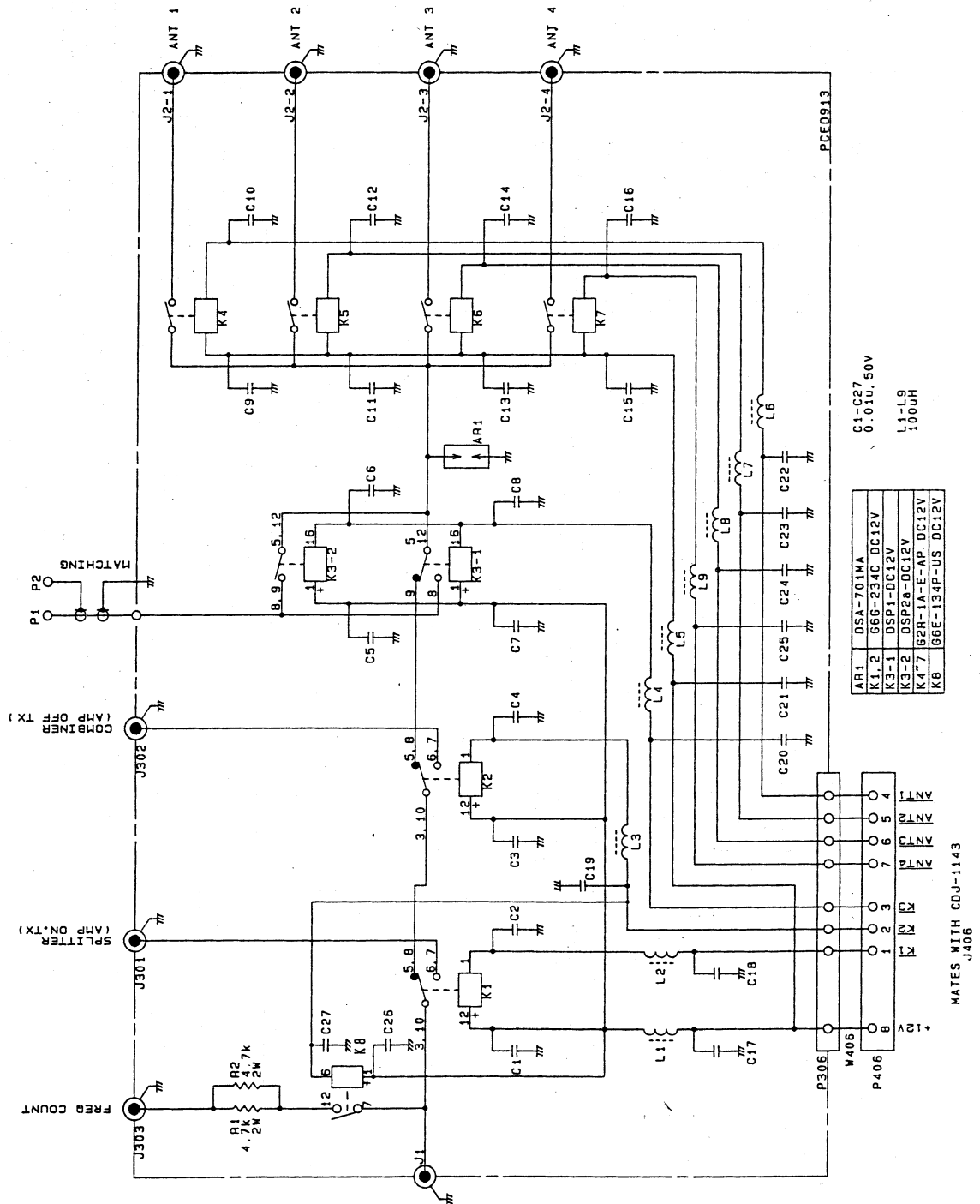

7.7 CSD-387 Switch Panel

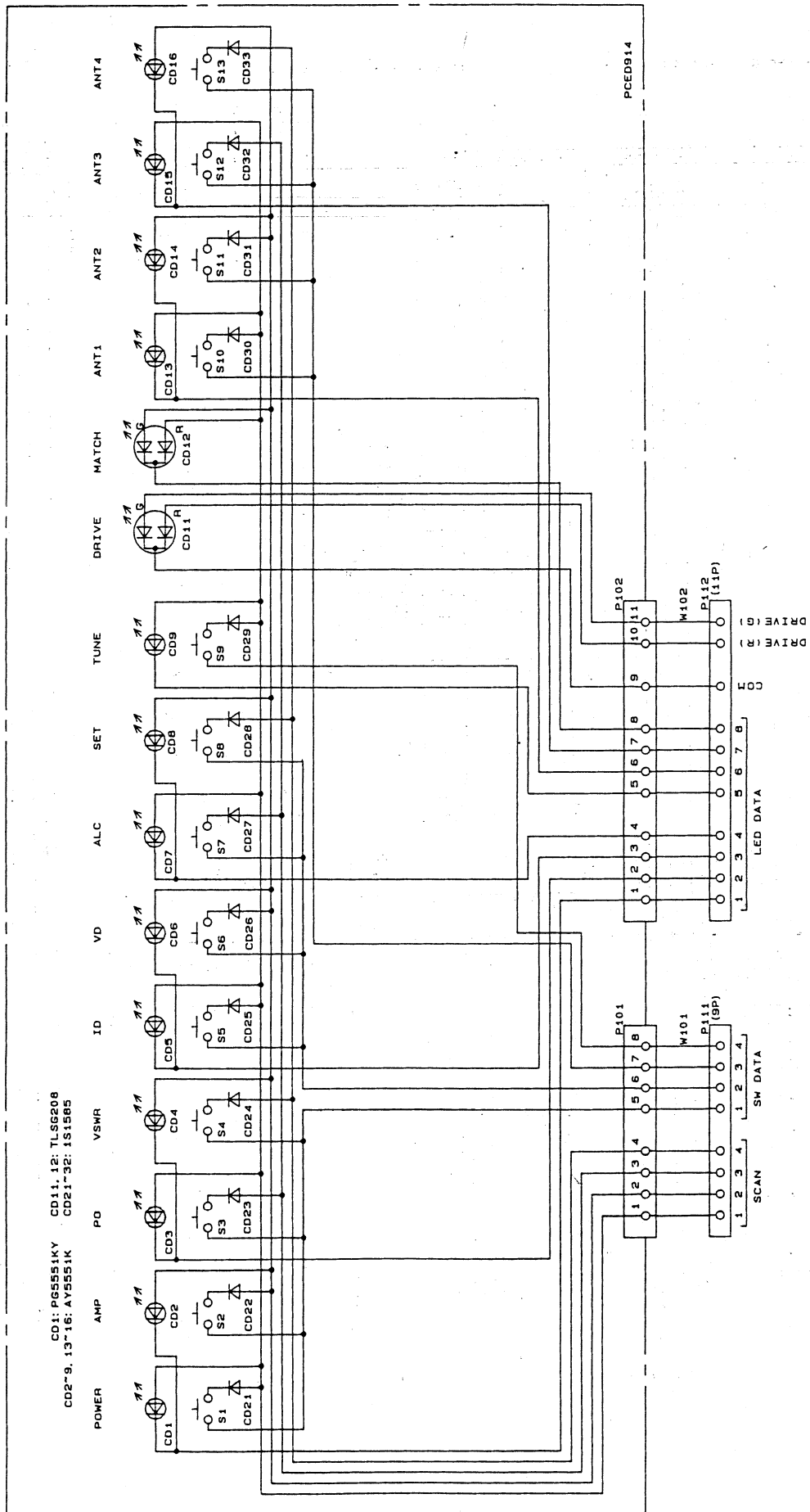

8. Print Circuit Board Layout

8.1 NAH-232 Power Amplifier Unit -----	56
8.1.1 CAH-377 Power Amplifier -----	58
8.1.2 CCB-367 PA Control -----	59
8.1.3 CFF-361 Power Combiner-----	60
8.2 NBL-169 Power Supply Unit -----	61
8.2.1 CSA-222 Relay Circuit -----	63
8.2.2 CBB-13 Power Factor Corrector -----	64
8.2.3 CBG-68 Main PS Unit -----	65
8.2.4 CFR-102 Noise Filter -----	66
8.3 CFG-111 Matching Circuit -----	67
8.4 CSC-433 Antenna Switch -----	68
8.5 CDJ-1143 Control -----	69
8.6 CML-334 Display -----	70
8.7 CSD-387 Switch Panel -----	71

8.1 NAH-232 Power Amplifier Unit

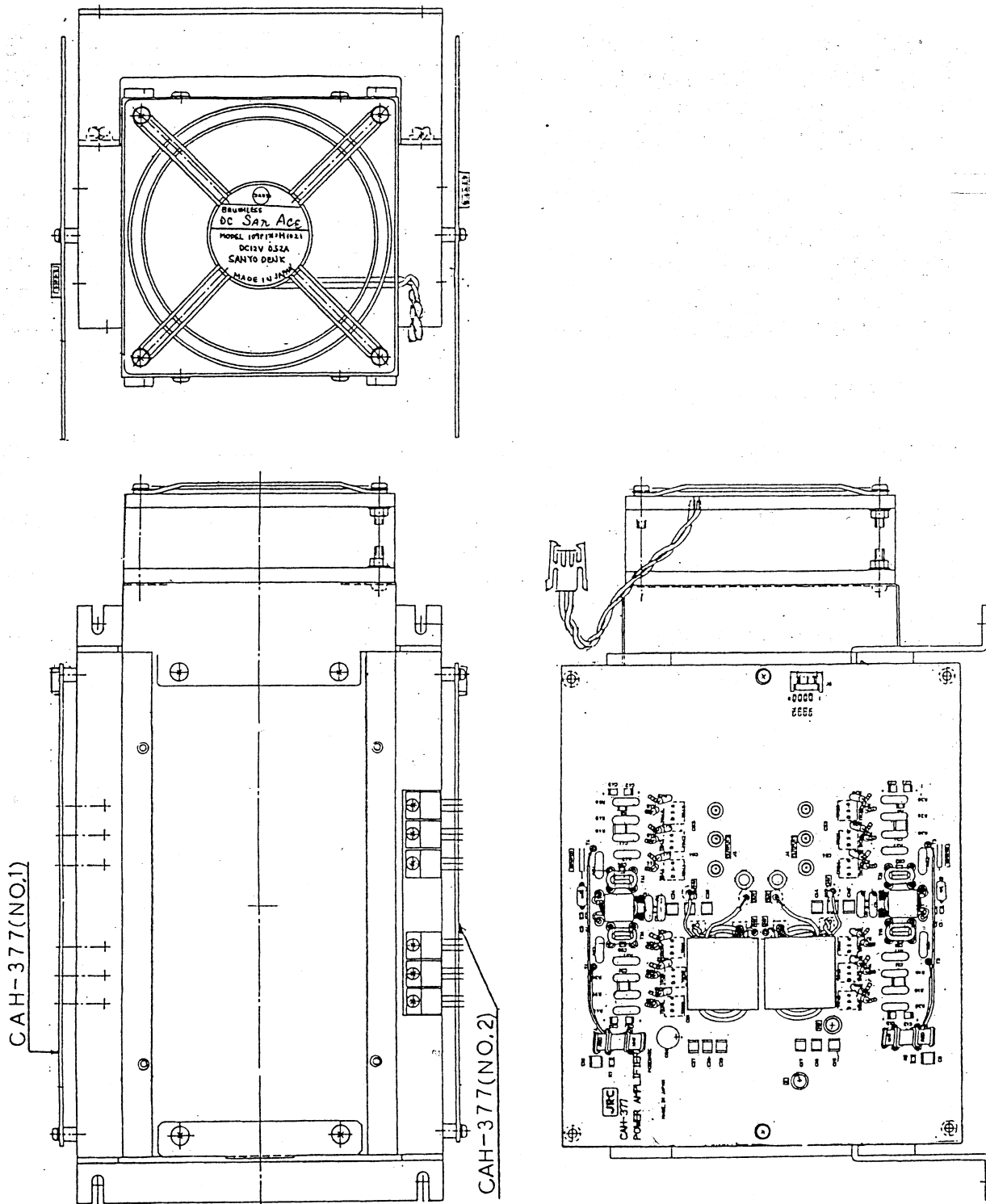

POWER SUPPLY UNIT (1/2)

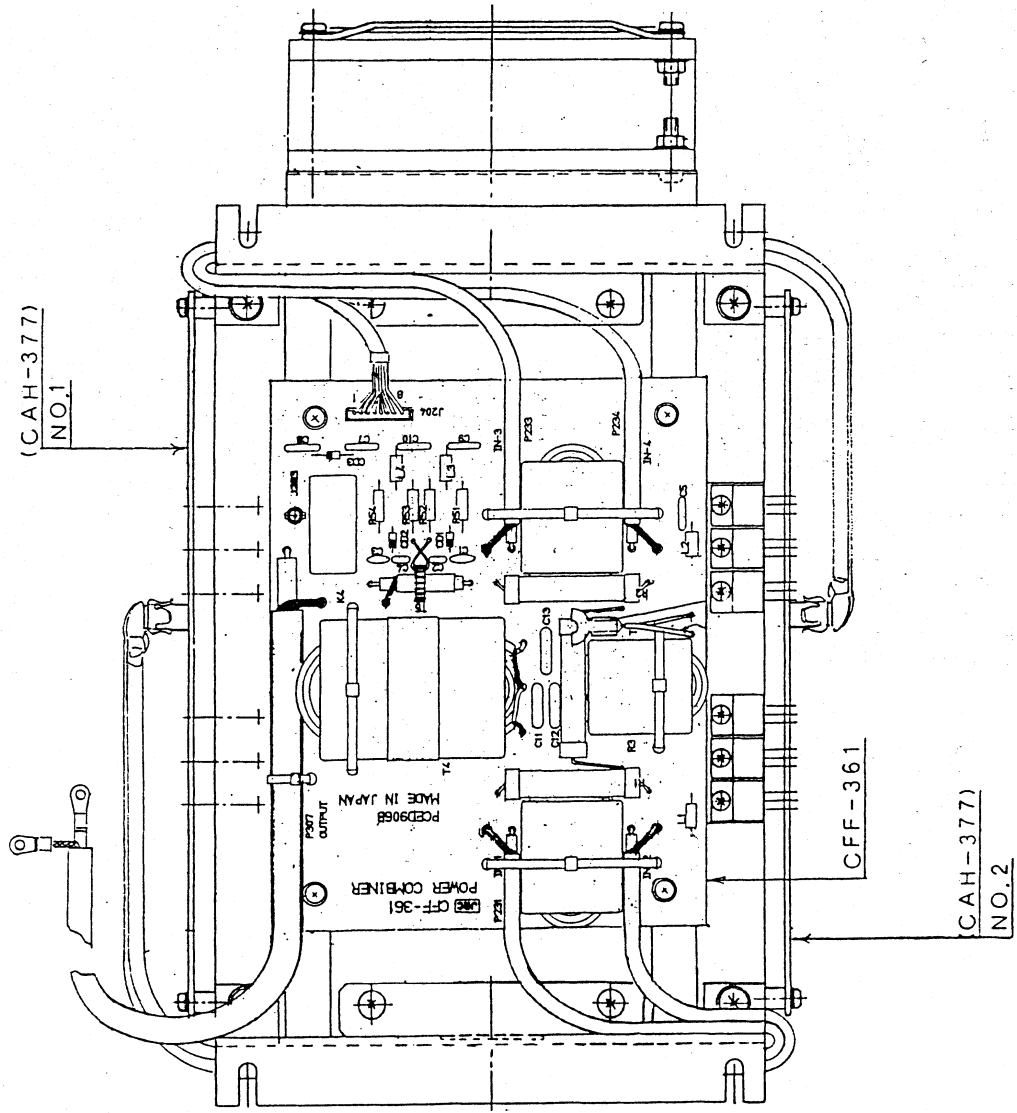
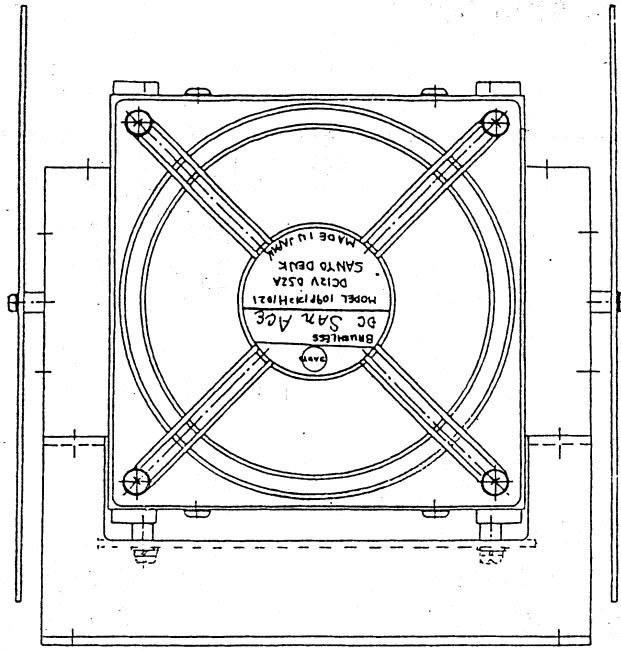

POWER SUPPLY UNIT (2/2)

8.1.1 CAH-377 Power Amplifier

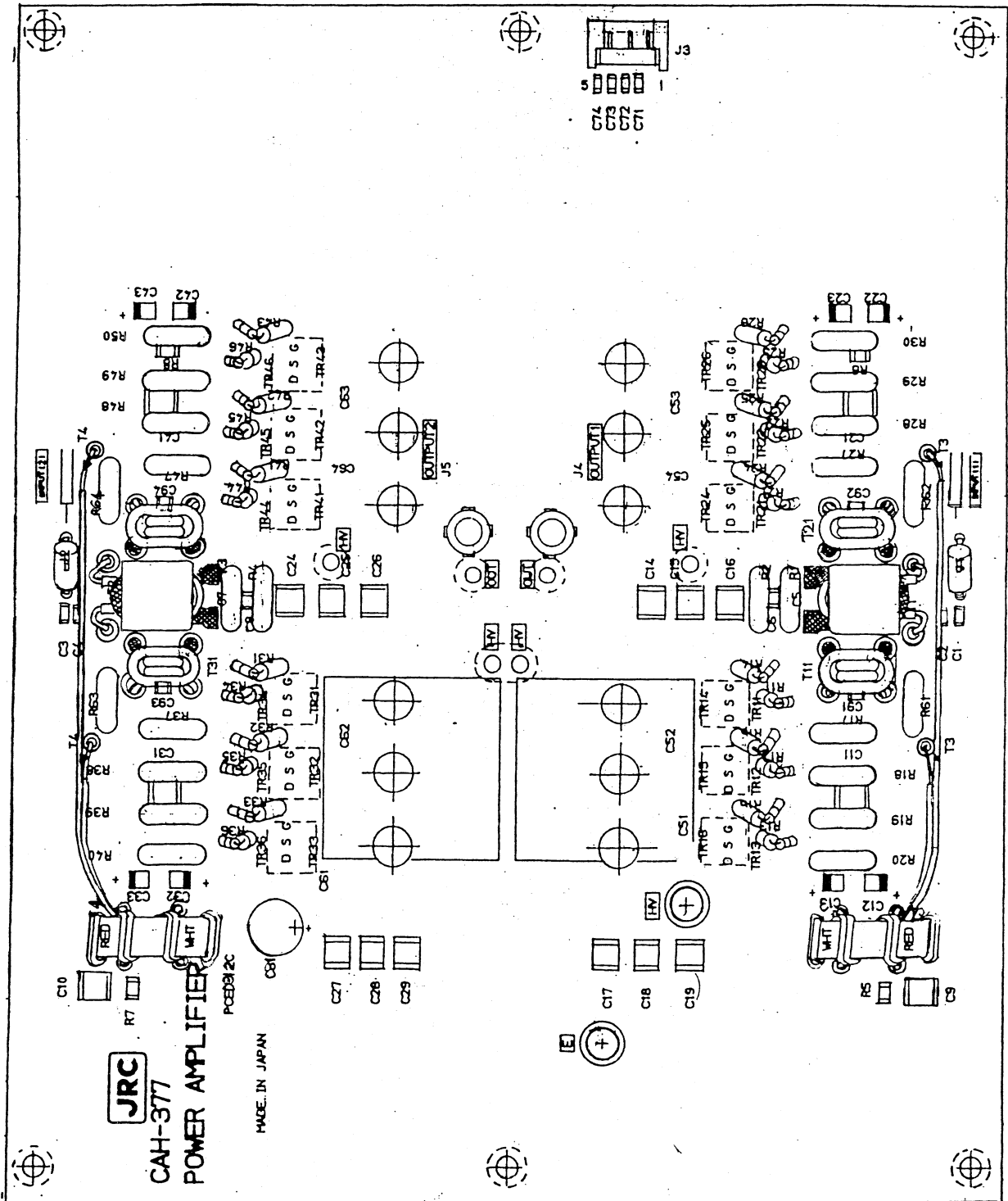

8.1.2 CCB-367 PA Control

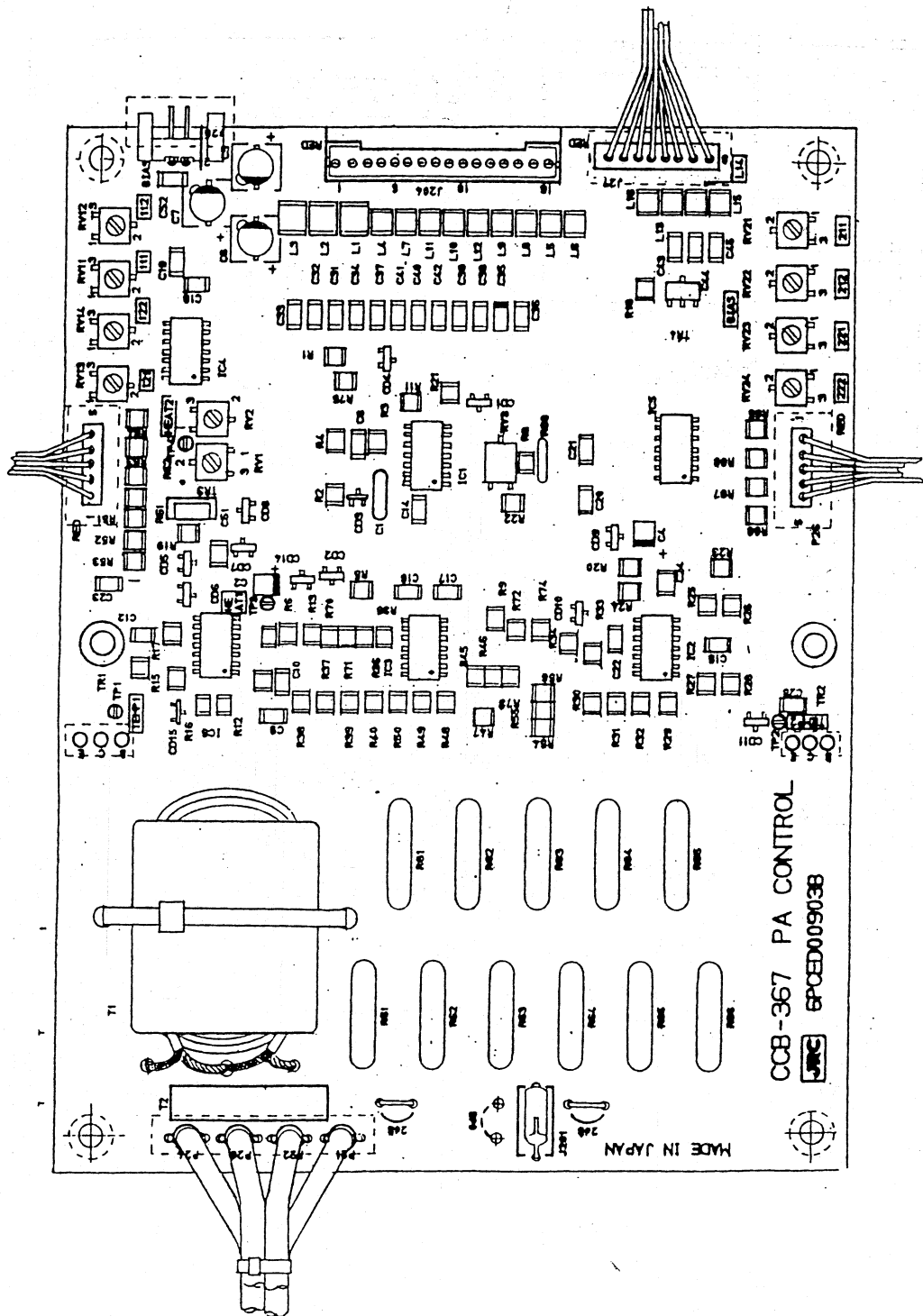

8.1.3 CFF-361 Power Combiner

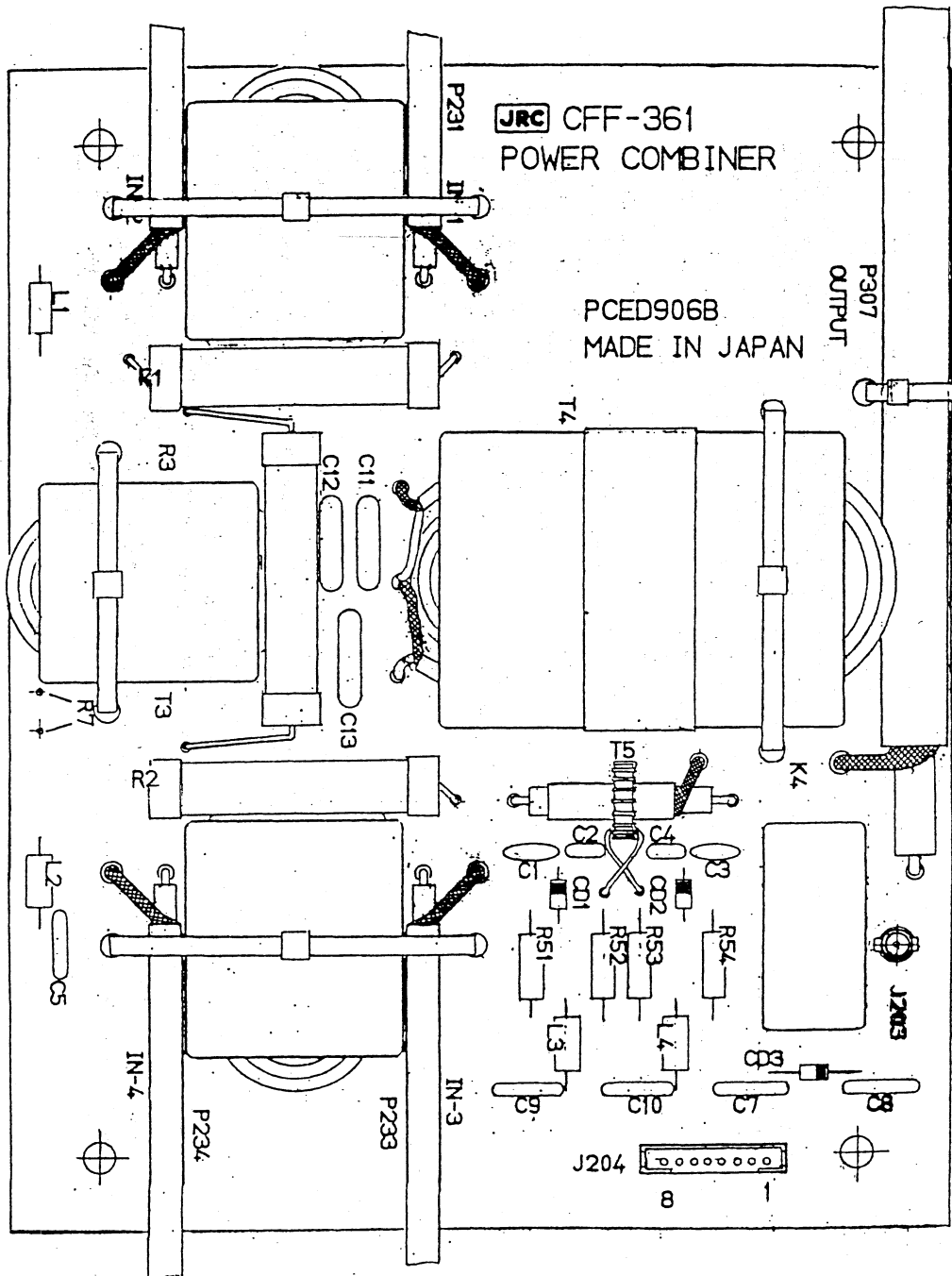

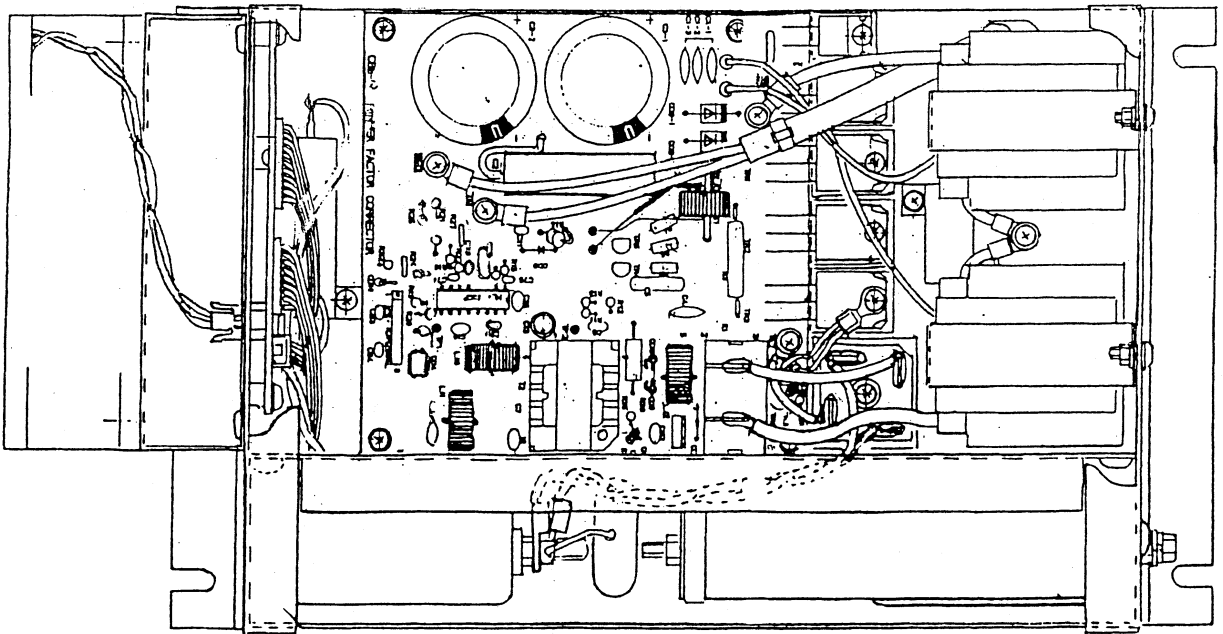
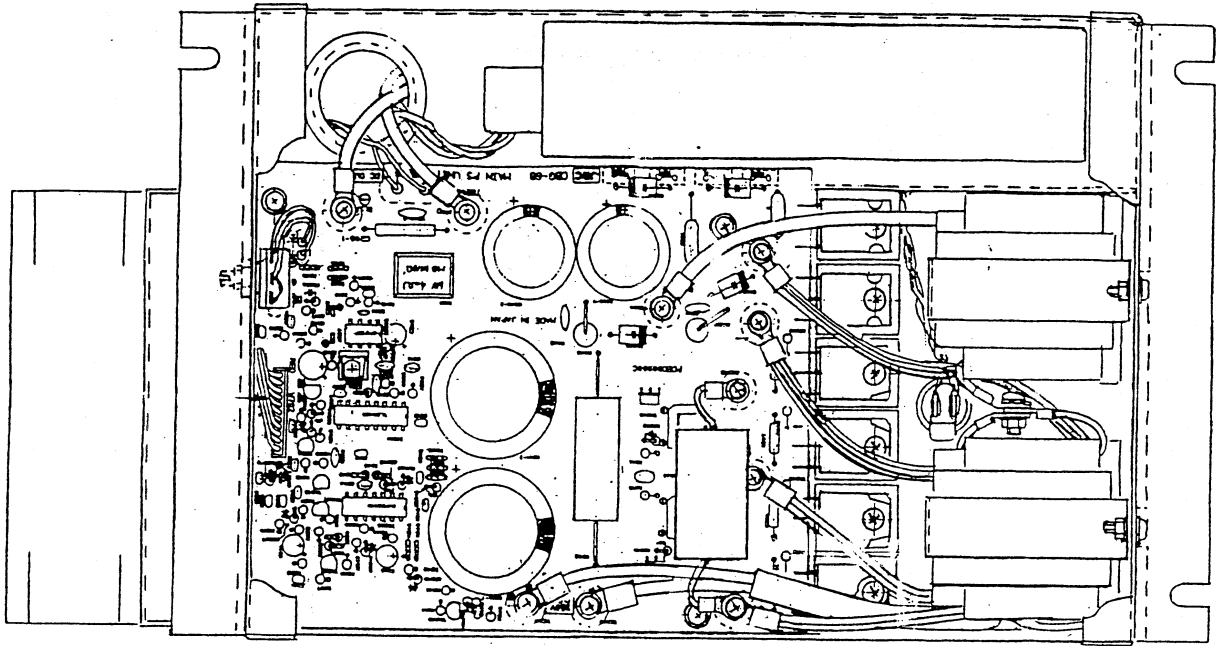

POWER AMPLIFIER (2/2)

8.2.1 CSA-222 Relay Circuit

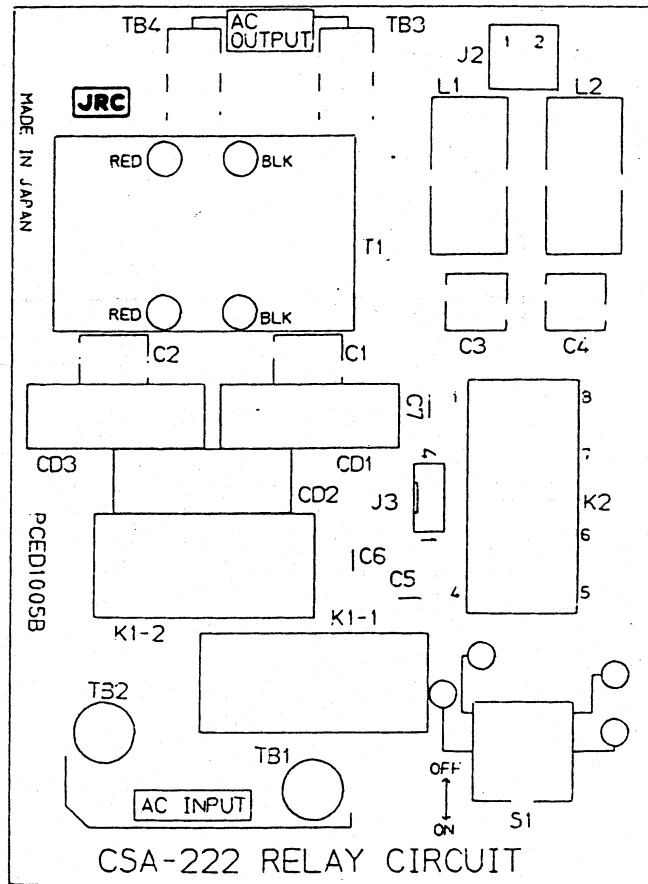

8.2.2 CBB-13 Power Factor Corrector

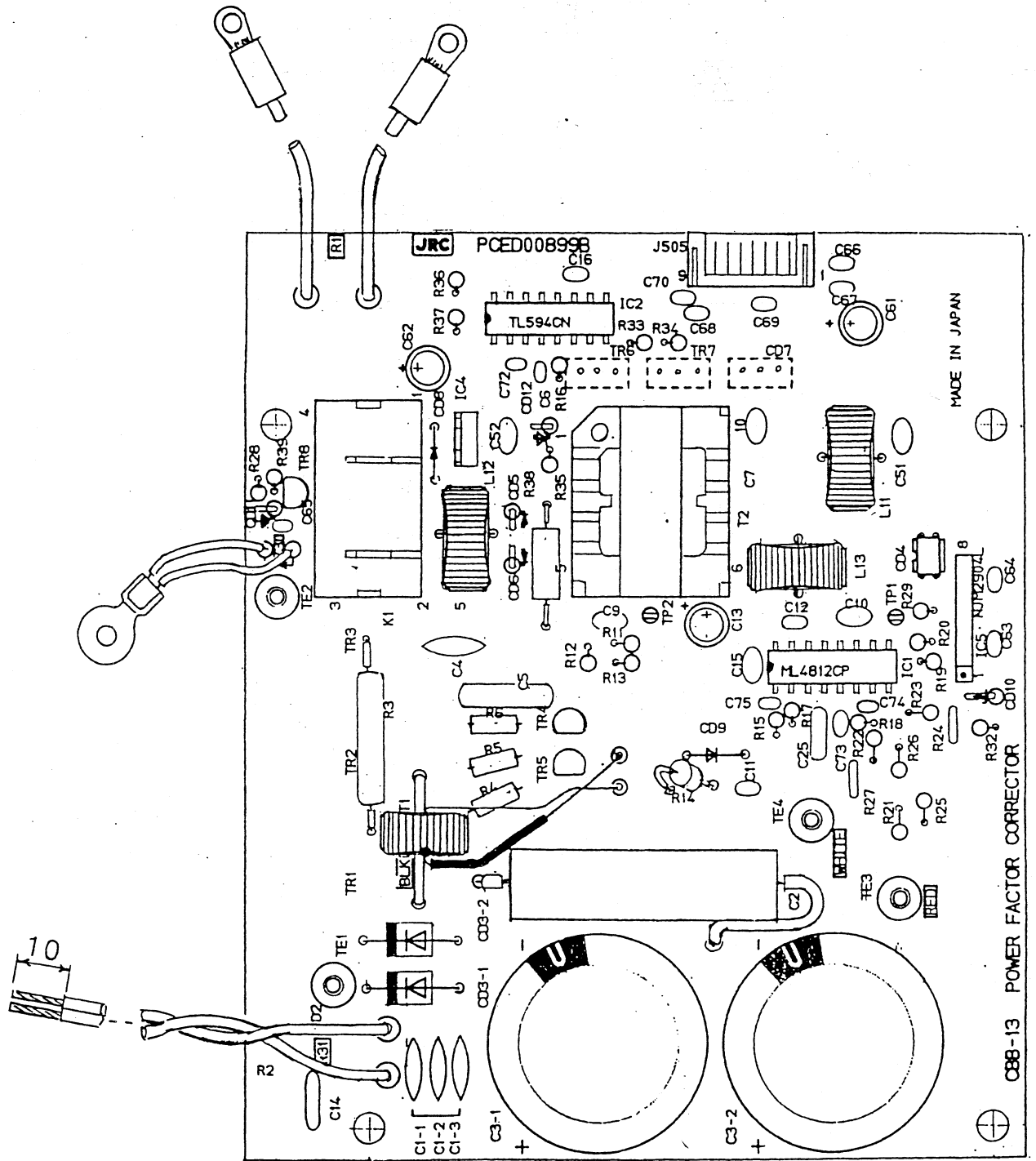

8.2.3 CBG-68 Main PS Unit

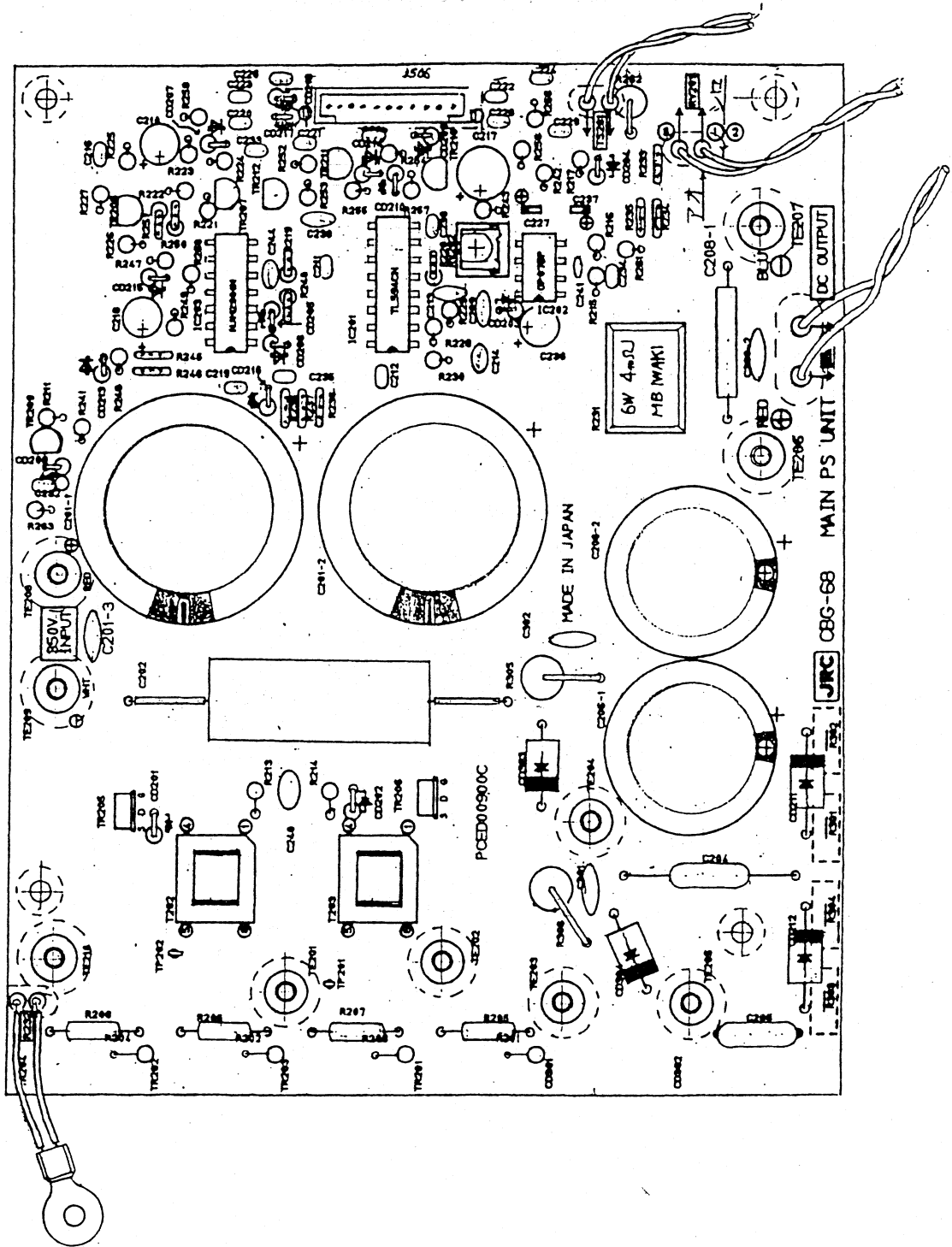

8.2.4 CFR-102 Noise Filter

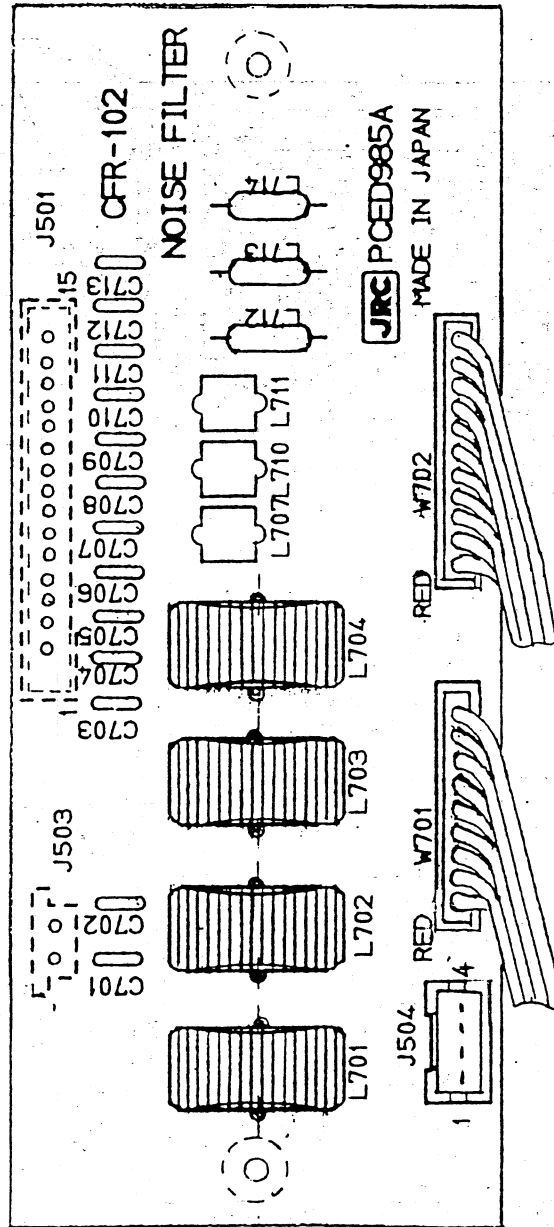

8.3 CFG-111 Matching Circuit

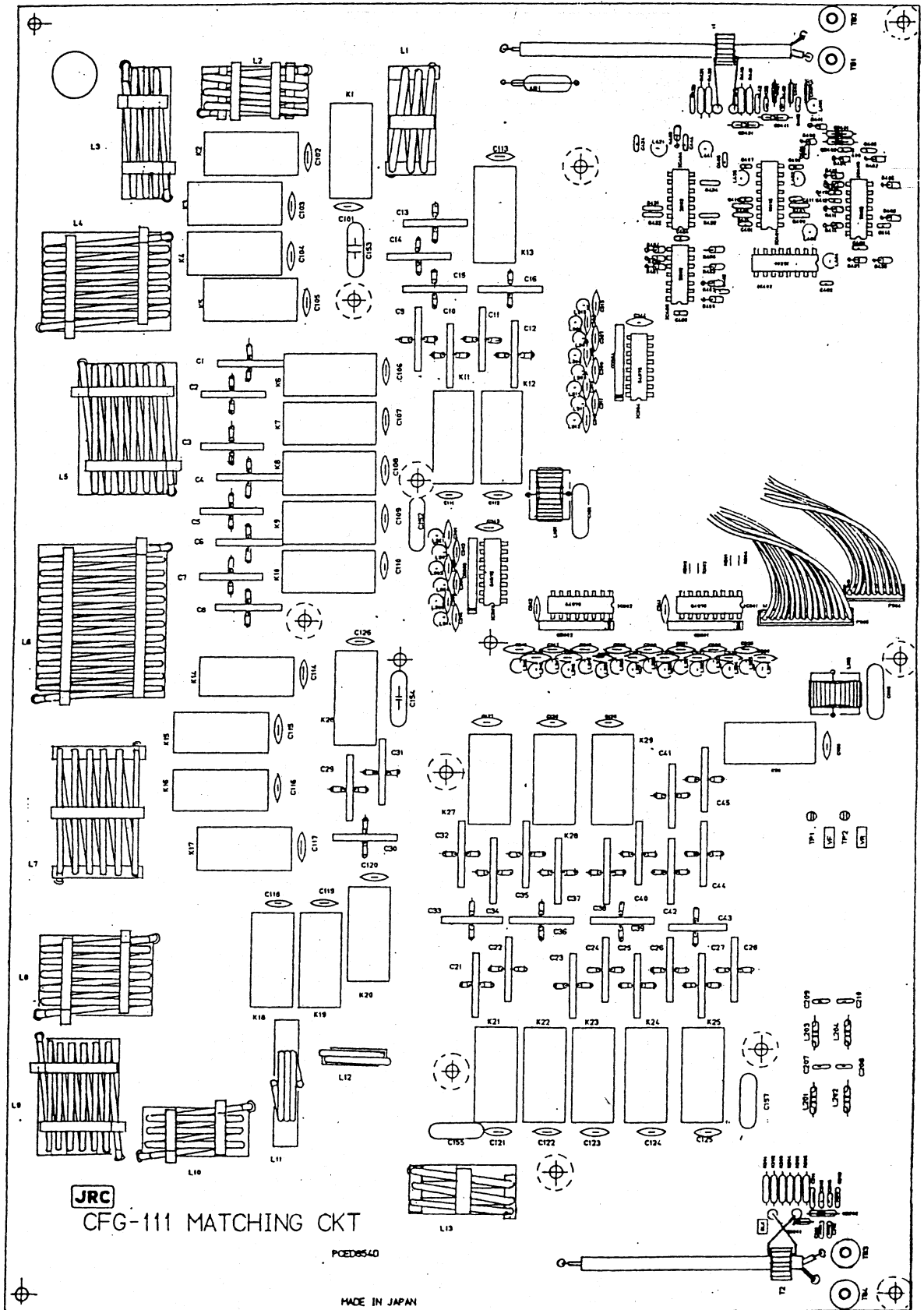

8.4 CSC-433 Antenna Switch

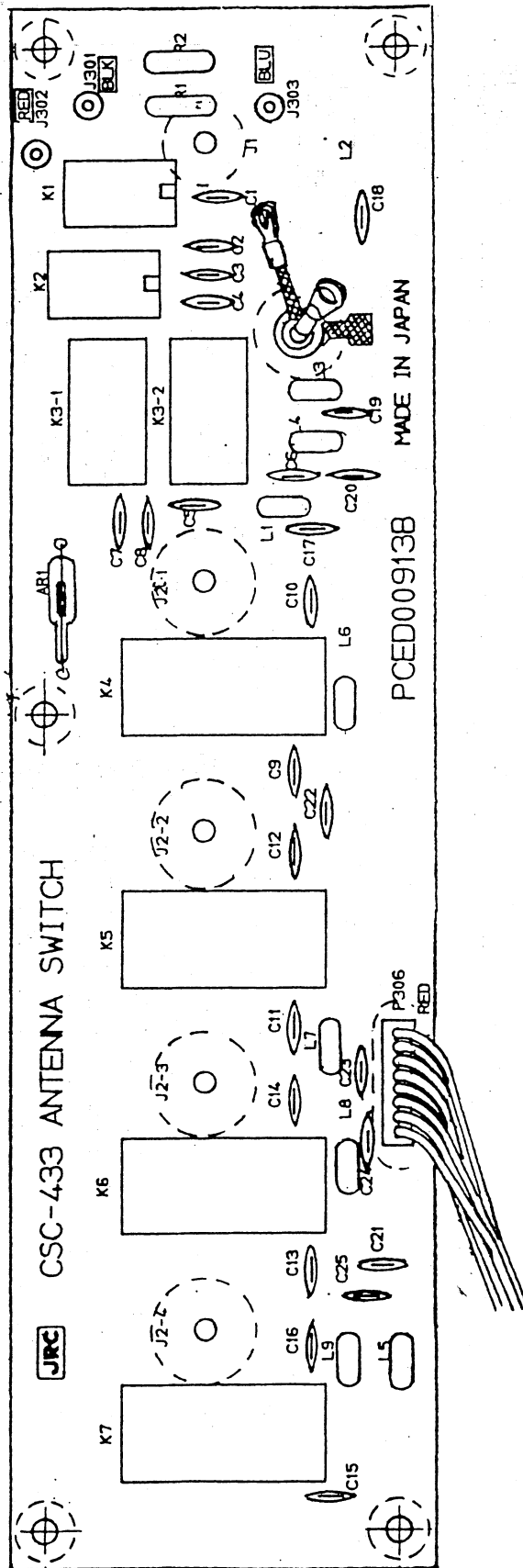

8.5 CDJ-1143 Control

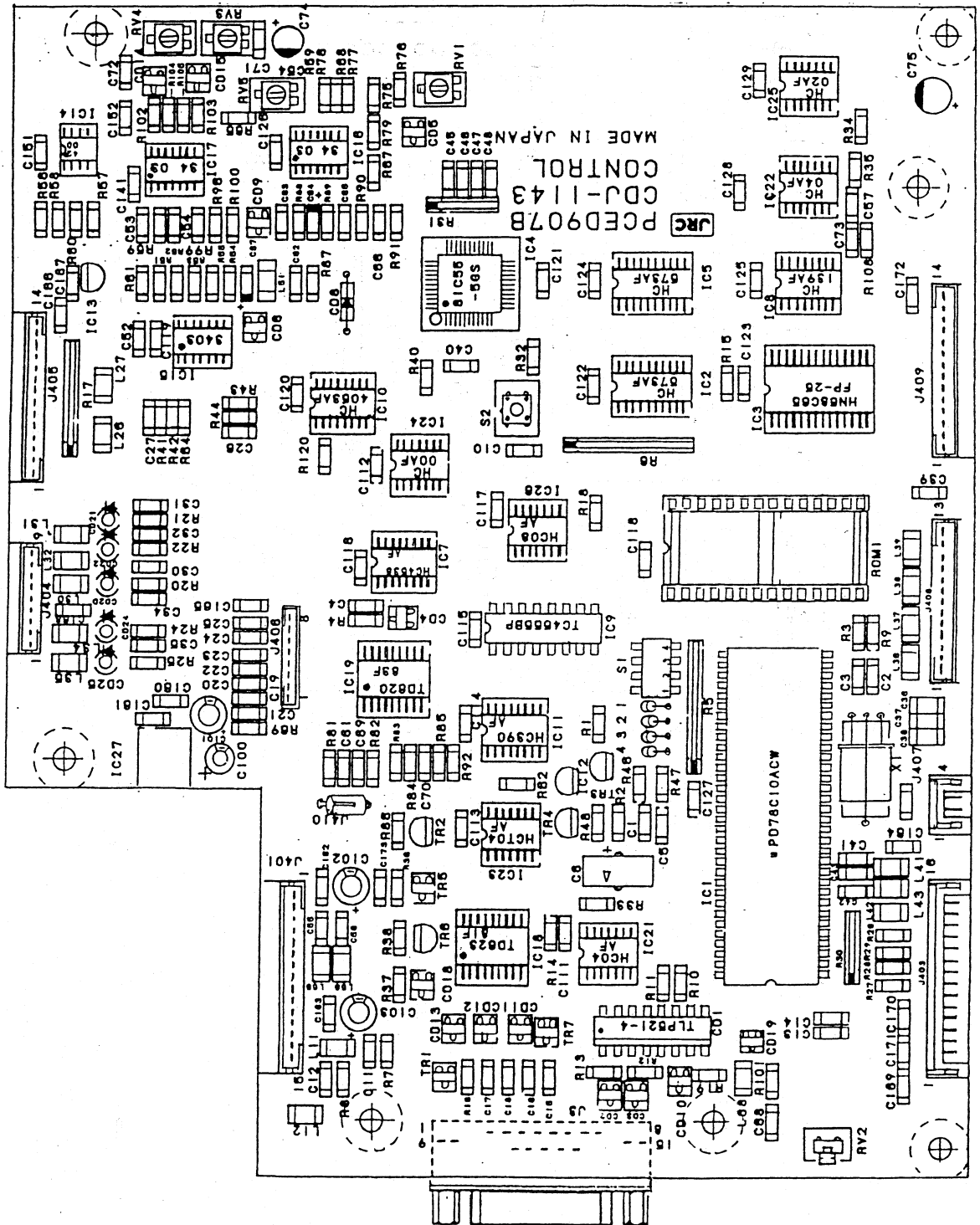

8.6 CML-334 Display

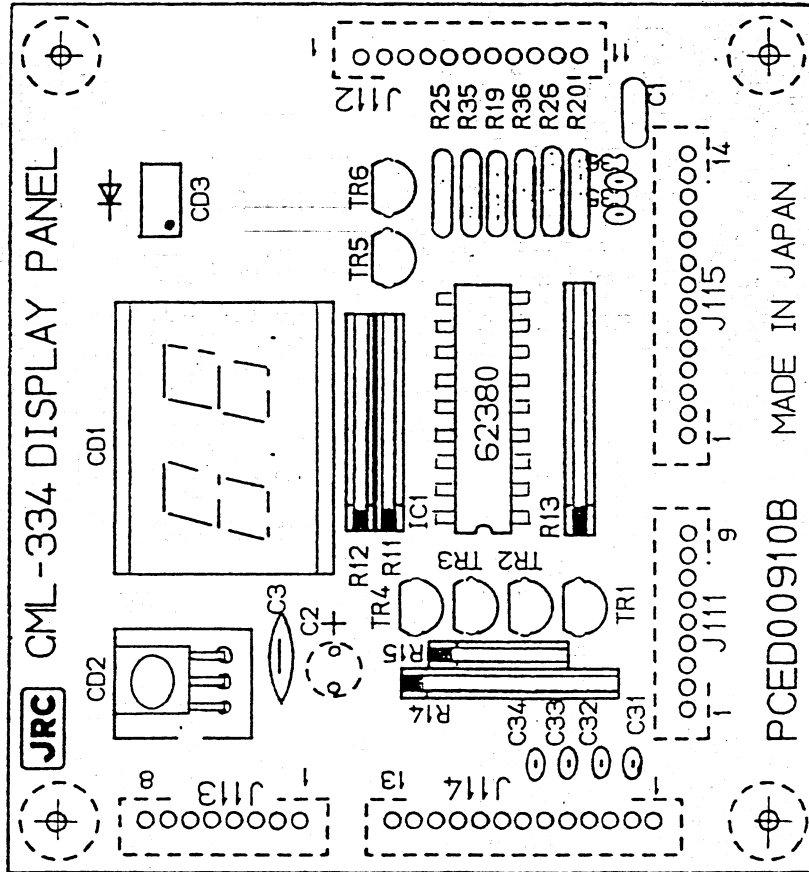

8.7 CSD-387 Switch Panel

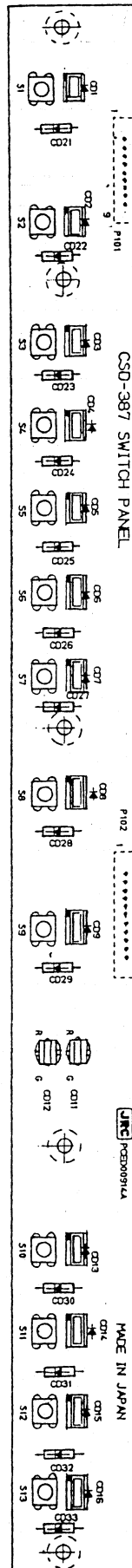

9. Replacement Parts List

9.1 JRL-2000F Linear AMP -----	73
9.2 NAH-232 Power Amplifier Unit -----	73
9.3 CCB-367 PA Control -----	74
9.4 CAH-377 Power Amplifier-----	77
9.5 CFF-361 Power Combiner -----	80
9.6 NBL-169 Power Supply Unit -----	81
9.7 CBG-68 Main PS Unit-----	82
9.8 CBB-13 Power Factor Corrector -----	84
9.9 CFR-102 Noise Filter -----	86
9.10 CSA-222 Relay Circuit -----	86
9.11 CFG-111 Matching Circuit -----	87
9.12 CSC-433 Antenna Switch -----	91
9.13 CDJ-1143 Control -----	92
9.14 CML-334 Display -----	97
9.15 CSD-387 Switch Panel-----	98
9.16 JRL-2000F-ACC Liner Accesory -----	99

73

PARTS LIST

PARTS LIST		TITLE		SHEET NO.	
PA UNIT		NAH-232		1	
PART NO	PART NAME	TYPE	DESCRIPTION	CODE	
B1	FAN	109P	1212H-1021	5BFAB00231	
BS1	BUSING	YC-40B		5ZZDY00005	
FG1	FAN	109-019C		5BFAB00023	
P28	CONNECTOR	HNC2-2.5S-2	2P	5JDA000279	
P28C	CONTACT	HNC-2.5S-D-B		5JDA000408	
R88	RESISTOR FXD	RE35-YQ-6.2K	OHM F	5READ00153	
T5	RF XFMR	H-6LHED00279A		6LHED00279	
T6	RF XFMR	H-6LHED00279A		6LHED00279	
TR11	TRANSISTOR	2SK408-01		5TKAB00098	
TR12	TRANSISTOR	2SK408-01		5TKAB00098	
TR13	TRANSISTOR	2SK408-01		5TKAB00098	
TR14	TRANSISTOR	2SK409-01		5TKAB00099	
TR15	TRANSISTOR	2SK409-01		5TKAB00099	
TR16	TRANSISTOR	2SK409-01		5TKAB00099	
TR21	TRANSISTOR	2SK408-01		5TKAB00098	
TR22	TRANSISTOR	2SK408-01		5TKAB00098	
TR23	TRANSISTOR	2SK408-01		5TKAB00098	
TR24	TRANSISTOR	2SK409-01		5TKAB00099	
TR25	TRANSISTOR	2SK409-01		5TKAB00099	
TR26	TRANSISTOR	2SK409-01		5TKAB00099	
TR31	TRANSISTOR	2SK408-01		5TKAB00098	
TR32	TRANSISTOR	2SK408-01		5TKAB00098	
TR33	TRANSISTOR	2SK408-01		5TKAB00098	
TR34	TRANSISTOR	2SK409-01		5TKAB00099	
TR35	TRANSISTOR	2SK409-01		5TKAB00099	
TR36	TRANSISTOR	2SK409-01		5TKAB00099	
TR41	TRANSISTOR	2SK408-01		5TKAB00098	
TR42	TRANSISTOR	2SK408-01		5TKAB00098	
TR43	TRANSISTOR	2SK408-01		5TKAB00098	
TR44	TRANSISTOR	2SK409-01		5TKAB00099	
TR45	TRANSISTOR	2SK409-01		5TKAB00099	
TR46	TRANSISTOR	2SK409-01		5TKAB00099	
TRS1	THERMAL SHEET	H-6ZZED00007		6ZZED00007	
TRS2	THERMAL SHEET	H-6ZZED00007		6ZZED00007	
TRS3	THERMAL SHEET	H-6ZZED00007		6ZZED00007	

9.2 NAH-232 Power Amplifier Unit

PARTS LIST

PARTS LIST		TITLE		SHEET NO.	
LINEAR AMP		JRL-2000F		1	
PART NO	PART NAME	TYPE	DESCRIPTION	CODE	
F1	FUSE	F-7165-15A	15A	5ZFAF00128	
F2	FUSE	F-7165-15A	15A	5ZFAF00128	
F3	FUSE	MF60NR-15A	15A	5ZFAD00173	
F4	FUSE	MF60NR-15A	15A	5ZFAD00173	
FS1	FUSE HOLDER	F-30		5ZFAF00060	
FS2	FUSE HOLDER	F-30		5ZFAF00060	
FS3	FUSE HOLDER	H-6ZJED00007A		6ZJED00007	
FS4	FUSE HOLDER	H-6ZJED00007A		6ZJED00007	
IC27	IC	TA78005AP		5DAAD00082	
M1	METER	H-6HMED00297		6HMED00297	
M2	METER	H-6HMED00298		6HMED00298	
P1	PLUG	WH4007		5JWAA00007	
W1	CABLE	H-6ZCED12006		6ZCED12006	
W3	CABLE	H-6ZCED12001	16P,500	6ZCED12001	
W7	CABLE	H-6ZCED12004		6ZCED12004	
W8	CABLE	H-6ZCED12005		6ZCED12005	
W9	CABLE	H-6ZCED12007		6ZCED12007	
W11	WIRE	VCTF-37/0.26 X 3C		2235100837	
W15	WIRE	250V-HV-37/0.26-(0)	H-6486-1	2265100038	
W16	WIRE	250V-HV-37/0.26-(9)	H-6486-1	2265100938	
W103	CABLE	H-6ZCED13004	8P 200	6ZCED13004	
WB1	BELT	MINI-BELT C		BRBP00219	

9.1 JRL-2000F Linear AMP

PARTS LIST

		TITLE		SHEET NO.	
		PA CONTROL		CCB-367	
PART NO	PART NAME	TYPE	DESCRIPTION	CODE	
C1	CAP,FXD	PLSTC	ECQ-V1H333JZ	0.033UF	5CRAA00510
J28	CONNECTOR		HNC2-2.5P-2DSL		5JDAA00299
J201	CONNECTOR		TMP-J01X-A2		5JWCL00045
J204	CONNECTOR		B16B-PH-K		5JWAP00446
P28C	CONTACT		HNC-2.5S-D-B		5JDAA00408
R61	RESISTOR	FXD	RSS5FB18 OHM JH1	5W 18 OHM	5REAS00007
R62	RESISTOR	FXD	RSS5FB18 OHM JH1	5W 18 OHM	5REAS00007
R63	RESISTOR	FXD	RSS5FB18 OHM JH1	5W 18 OHM	5REAS00007
R64	RESISTOR	FXD	RSS5FB18 OHM JH1	5W 18 OHM	5REAS00007
R65	RESISTOR	FXD	RSS5FB18 OHM JH1	5W 18 OHM	5REAS00007
R66	RESISTOR	FXD	RSS5FB18 OHM JH1	5W 18 OHM	5REAS00007
R67	RESISTOR	FXD	RSS5FB1K OHM JH1		5REAS00008
R68	RESISTOR	FXD	RSS5FB1K OHM JH1		5REAS00008
R69	RESISTOR	FXD	RSS5FB1K OHM JH1		5REAS00008
R70	RESISTOR	FXD	RSS5FB1K OHM JH1		5REAS00008
R71	RESISTOR	FXD	RSS5FB1K OHM JH1		5REAS00008
R88	RESISTOR	FXD	RE35-YQ-6.2K OHM F		5READ00153
T1	RF XFMR		H-6LHED00359A		6LHED00359
TP1	TERMINAL		CP-8		5JTBV00005
TP2	TERMINAL		CP-8		5JTBV00005
TP3	TERMINAL		CP-8		5JTBV00005
TP4	TERMINAL		CP-8		5JTBV00005
TR1	TRANSISTOR		2SD1508		5TDAE00194
TR2	TRANSISTOR		2SD1508		5TDAE00194
TR3	TRANSISTOR		2SD1508		5TDAE00194
W21	CABLE		H-6ZCED11013		6ZCED11013
W22	CABLE		H-6ZCED11013		6ZCED11013
W23	CABLE		H-6ZCED11014		6ZCED11014
W41	CABLE		H-6ZCED00310		6ZCED00310
W42	CABLE		H-6ZCED00310		6ZCED00310
W43	CABLE		H-6ZCED00310		6ZCED00310
W44	CABLE		H-6ZCED00310		6ZCED00310

74

9.3 CCB-367 PA Control

PARTS LIST

		TITLE		SHEET NO.	
		PA UNIT		NAH-232	
PART NO	PART NAME	TYPE	DESCRIPTION	CODE	
TRS4	THERMAL SHEET		H-6ZZED00007	6ZZED00007	

75

PARTS LIST

		TITLE		SHEET NO.	
		PA CONTROL		CCB-367-CHIP	
				2	
PART NO	PART NAME	TYPE	DESCRIPTION	CODE	
C43	CAP,FXD C CER	C3216JB1H103K-E-TP	50V 0.01UF	5CAAD00789	
C44	CAP,FXD C CER	C3216JB1H103K-E-TP	50V 0.01UF	5CAAD00789	
C45	CAP,FXD C CER	C3216JB1H103K-E-TP	50V 0.01UF	5CAAD00789	
C51	CAP,FXD C CER	C3216JB1H103K-E-TP	50V 0.01UF	5CAAD00789	
C52	CAP,FXD C CER	C3216JB1H103K-E-TP	50V 0.01UF	5CAAD00789	
CD1	DIODE	1SS181 TE85L		5TXAD00356	
CD2	DIODE	1SS181 TE85L		5TXAD00356	
CD3	DIODE	1SS181 TE85L		5TXAD00356	
CD4	DIODE	1SS181 TE85L		5TXAD00356	
CD5	DIODE	1SS181 TE85L		5TXAD00356	
CD6	DIODE	1SS181 TE85L		5TXAD00356	
CD7	DIODE	1SS181 TE85L		5TXAD00356	
CD8	DIODE	1SS181 TE85L		5TXAD00356	
CD9	DIODE	1SS181 TE85L		5TXAD00356	
CD10	DIODE	1SS181 TE85L		5TXAD00356	
CD11	DIODE	1SS181 TE85L		5TXAD00356	
CD14	DIODE	02CZ5.1X-TE85R		5TXAD00577	
CD15	DIODE	HZM6BTL		5TXAE00805	
IC1	IC	NJM2902M-TE1		5DAAN00421	
IC2	IC	NJM2902M-TE1		5DAAN00421	
IC3	IC	NJM2902M-TE1		5DAAN00421	
IC4	IC	NJM2902M-TE1		5DAAN00421	
IC5	IC	NJM2902M-TE1		5DAAN00421	
IC6	IC	NJM2902M-TE1		5DAAN00421	
L1	COIL	LQH4N101K-S		5LCAP00092	
L2	COIL	LQH4N101K-S		5LCAP00092	
L3	COIL	LQH4N101K-S		5LCAP00092	
L4	COIL	LQH3N101K04	100UH	5LCAP00214	
L5	COIL	LQH3N101K04	100UH	5LCAP00214	
L6	COIL	LQH3N101K04	100UH	5LCAP00214	
L7	COIL	LQH3N101K04	100UH	5LCAP00214	
L8	COIL	LQH3N101K04	100UH	5LCAP00214	
L9	COIL	LQH3N101K04	100UH	5LCAP00214	
L10	COIL	LQH3N101K04	100UH	5LCAP00214	
L11	COIL	LQH3N101K04	100UH	5LCAP00214	

PARTS LIST

		TITLE		SHEET NO.	
		PA CONTROL		CCB-367-CHIP	
				1	
PART NO	PART NAME	TYPE	DESCRIPTION	CODE	
C2	CAP,FXD TANTAL	267M1002 475ML	10V 4.7UF	5CSAC01281	
C4	CAP,FXD TANTAL	267M1002 475ML	10V 4.7UF	5CSAC01281	
C5	CAP,FXD ELCTLT	ECE-V1CA470P	47UF 16V	5CEAA02625	
C6	CAP,FXD ELCTLT	ECE-V1CA470P	47UF 16V	5CEAA02625	
C7	CAP,FXD ELCTLT	ECE-V1CA470P	47UF 16V	5CEAA02625	
C8	CAP,FXD C CER	C3216JF1H104Z-E-TP	50V 0.1UF	5CAAD01268	
C9	CAP,FXD C CER	C3216JF1H104Z-E-TP	50V 0.1UF	5CAAD01268	
C10	CAP,FXD C CER	C3216JF1H104Z-E-TP	50V 0.1UF	5CAAD01268	
C11	CAP,FXD C CER	C3216JF1H104Z-E-TP	50V 0.1UF	5CAAD01268	
C12	CAP,FXD C CER	C3216JF1H104Z-E-TP	50V 0.1UF	5CAAD01268	
C13	CAP,FXD C CER	C3216JF1H104Z-E-TP	50V 0.1UF	5CAAD01268	
C14	CAP,FXD C CER	C3216JF1H104Z-E-TP	50V 0.1UF	5CAAD01268	
C15	CAP,FXD C CER	C3216JF1H104Z-E-TP	50V 0.1UF	5CAAD01268	
C16	CAP,FXD C CER	C3216JF1H104Z-E-TP	50V 0.1UF	5CAAD01268	
C17	CAP,FXD C CER	C3216JF1H104Z-E-TP	50V 0.1UF	5CAAD01268	
C18	CAP,FXD C CER	C3216JF1H104Z-E-TP	50V 0.1UF	5CAAD01268	
C19	CAP,FXD C CER	C3216JF1H104Z-E-TP	50V 0.1UF	5CAAD01268	
C20	CAP,FXD C CER	C3216JF1H104Z-E-TP	50V 0.1UF	5CAAD01268	
C21	CAP,FXD C CER	C3216JF1H104Z-E-TP	50V 0.1UF	5CAAD01268	
C22	CAP,FXD C CER	C3216JF1H104Z-E-TP	50V 0.1UF	5CAAD01268	
C23	CAP,FXD C CER	C3216JF1H104Z-E-TP	50V 0.1UF	5CAAD01268	
C24	CAP,FXD C CER	C3216JB1H103K-E-TP	50V 0.01UF	5CAAD00789	
C25	CAP,FXD C CER	C3216JF1H104Z-E-TP	50V 0.1UF	5CAAD01268	
C31	CAP,FXD C CER	C3216JB1H103K-E-TP	50V 0.01UF	5CAAD00789	
C32	CAP,FXD C CER	C3216JB1H103K-E-TP	50V 0.01UF	5CAAD00789	
C33	CAP,FXD C CER	C3216JB1H103K-E-TP	50V 0.01UF	5CAAD00789	
C34	CAP,FXD C CER	C3216JB1H103K-E-TP	50V 0.01UF	5CAAD00789	
C35	CAP,FXD TANTAL	267M1602 105ML	16V 1UF	5CSAC01050	
C36	CAP,FXD C CER	C3216JB1H103K-E-TP	50V 0.01UF	5CAAD00789	
C37	CAP,FXD C CER	C3216JB1H103K-E-TP	50V 0.01UF	5CAAD00789	
C38	CAP,FXD C CER	C3216JB1H103K-E-TP	50V 0.01UF	5CAAD00789	
C39	CAP,FXD C CER	C3216JB1H103K-E-TP	50V 0.01UF	5CAAD00789	
C40	CAP,FXD C CER	C3216JB1H103K-E-TP	50V 0.01UF	5CAAD00789	
C41	CAP,FXD C CER	C3216JB1H103K-E-TP	50V 0.01UF	5CAAD00789	
C42	CAP,FXD C CER	C3216JB1H103K-E-TP	50V 0.01UF	5CAAD00789	

PARTS LIST

PARTS LIST					TITLE	SHEET NO.
PA CONTROL					CCB-367-CHIP	4
PART NO	PART NAME	TYPE	DESCRIPTION	CODE		
R32	RESISTOR FXD	ERJ-8GEYJ222V	1/8W 2.2K OHM	5REAG01742		
R33	RESISTOR FXD	ERJ-8GEYJ222V	1/8W 2.2K OHM	5REAG01742		
R34	RESISTOR FXD	ERJ-8GEYJ472V	1/8W 4.7K OHM	5REAG01746		
R35	RESISTOR FXD	ERJ-8GEYJ333V	1/8W 33K OHM	5REAG01756		
R36	RESISTOR FXD	ERJ-8GEYJ472V	1/8W 4.7K OHM	5REAG01746		
R37	RESISTOR FXD	ERJ-8GEYJ103V	1/8W 10K OHM	5REAG01750		
R38	RESISTOR FXD	ERJ-8GEYJ103V	1/8W 10K OHM	5REAG01750		
R39	RESISTOR FXD	ERJ-8GEYJ222V	1/8W 2.2K OHM	5REAG01742		
R40	RESISTOR FXD	ERJ-8GEYJ222V	1/8W 2.2K OHM	5REAG01742		
R45	RESISTOR FXD	ERJ-8GEYJ333V	1/8W 33K OHM	5REAG01756		
R46	RESISTOR FXD	ERJ-8GEYJ472V	1/8W 4.7K OHM	5REAG01746		
R47	RESISTOR FXD	ERJ-8GEYJ103V	1/8W 10K OHM	5REAG01750		
R48	RESISTOR FXD	ERJ-8GEYJ103V	1/8W 10K OHM	5REAG01750		
R49	RESISTOR FXD	ERJ-8GEYJ222V	1/8W 2.2K OHM	5REAG01742		
R50	RESISTOR FXD	ERJ-8GEYJ222V	1/8W 2.2K OHM	5REAG01742		
R51	RESISTOR FXD	ERJ-8GEYJ222V	1/8W 2.2K OHM	5REAG01742		
R52	RESISTOR FXD	ERJ-8GEYJ222V	1/8W 2.2K OHM	5REAG01742		
R53	RESISTOR FXD	ERJ-8GEYJ222V	1/8W 2.2K OHM	5REAG01742		
R54	RESISTOR FXD	ERJ-8GEYJ222V	1/8W 2.2K OHM	5REAG01742		
R55	RESISTOR FXD	ERJ-8GEYJ222V	1/8W 2.2K OHM	5REAG01742		
R56	RESISTOR FXD	ERJ-8GEYJ222V	1/8W 2.2K OHM	5REAG01742		
R61	RESISTOR FXD	ERJ-8GEYJ471V	1/8W 470 OHM	5REAG01734		
R62	RESISTOR FXD	ERJ-8GEYJ471V	1/8W 470 OHM	5REAG01734		
R63	RESISTOR FXD	ERJ-8GEYJ471V	1/8W 470 OHM	5REAG01734		
R64	RESISTOR FXD	ERJ-8GEYJ471V	1/8W 470 OHM	5REAG01734		
R65	RESISTOR FXD	ERJ-8GEYJ471V	1/8W 470 OHM	5REAG01734		
R66	RESISTOR FXD	ERJ-8GEYJ471V	1/8W 470 OHM	5REAG01734		
R67	RESISTOR FXD	ERJ-8GEYJ471V	1/8W 470 OHM	5REAG01734		
R68	RESISTOR FXD	ERJ-8GEYJ471V	1/8W 470 OHM	5REAG01734		
R70	RESISTOR FXD	ERJ-8GEYJ103V	1/8W 10K OHM	5REAG01750		
R71	RESISTOR FXD	ERJ-8GEYJ221V	1/8W 220 OHM	5REAG01730		
R72	RESISTOR FXD	ERJ-8GEYJ103V	1/8W 10K OHM	5REAG01750		
R73	RESISTOR FXD	ERJ-8GEYJ221V	1/8W 220 OHM	5REAG01730		
R74	RESISTOR CFXD	ERJ-8GEYJ101V	1/8W 100 OHM	5REAG01726		
R75	RESISTOR CFXD	ERJ-8GEYJ101V	1/8W 100 OHM	5REAG01726		

PARTS LIST

PARTS LIST					TITLE	SHEET NO.
PA CONTROL					CCB-367-CHIP	3
PART NO	PART NAME	TYPE	DESCRIPTION	CODE		
L12	COIL	LQH3N101K04	100UH	5LCAP00214		
L13	COIL	LQH3N101K04	100UH	5LCAP00214		
L14	COIL	LQH3N101K04	100UH	5LCAP00214		
L15	COIL	LQH3N101K04	100UH	5LCAP00214		
L16	COIL	LQH3N101K04	100UH	5LCAP00214		
PC1	PCB	H-6PCED00903E	CCB-367	6PCED00903		
R1	RESISTOR FXD	ERJ-8GEYJ103V	1/8W 10K OHM	5REAG01750		
R2	RESISTOR FXD	ERJ-8GEYJ154V	1/8W 150K OHM	5REAG01764		
R3	RESISTOR FXD	ERJ-8GEYJ222V	1/8W 2.2K OHM	5REAG01742		
R4	RESISTOR FXD	ERJ-8GEYJ222V	1/8W 2.2K OHM	5REAG01742		
R5	RESISTOR FXD	ERJ-8GEYJ473V	1/8W 47K OHM	5REAG01758		
R6	RESISTOR FXD	ERJ-8GEYJ471V	1/8W 470 OHM	5REAG01734		
R8	RESISTOR FXD	ERJ-8GEYJ512V	1/8W 5.1K OHM	5REAG02196		
R9	RESISTOR FXD	ERJ-8GEYJ103V	1/8W 10K OHM	5REAG01750		
R11	RESISTOR FXD	ERJ-8GEYJ103V	1/8W 10K OHM	5REAG01750		
R12	RESISTOR FXD	ERJ-8GEYJ152V	1/8W 1.5K OHM	5REAG01740		
R13	RESISTOR FXD	ERJ-8GEYJ330V	1/8W 33 OHM	5REAG01720		
R14	RESISTOR FXD	ERJ-8GEYJ473V	1/8W 47K OHM	5REAG01758		
R15	RESISTOR FXD	ERJ-8GEYJ473V	1/8W 47K OHM	5REAG01758		
R16	RESISTOR FXD	ERJ-8GEYJ152V	1/8W 1.5K OHM	5REAG01740		
R17	RESISTOR FXD	ERJ-8GEYJ330V	1/8W 33 OHM	5REAG01720		
R18	RESISTOR FXD	ERJ-8GEYJ222V	1/8W 2.2K OHM	5REAG01742		
R19	RESISTOR FXD	ERJ-8GEYJ102V	1/8W 1K OHM	5REAG01738		
R20	RESISTOR CFXD	ERJ-8GEYJ104V	1/8W 100K OHM	5REAG01762		
R21	RESISTOR CFXD	ERJ-8GEYJ101V	1/8W 100 OHM	5REAG01726		
R22	RESISTOR FXD	ERJ-8GEYJ222V	1/8W 2.2K OHM	5REAG01742		
R23	RESISTOR FXD	ERJ-8GEYJ224V	1/8W 220K OHM	5REAG01766		
R24	RESISTOR FXD	ERJ-8GEYJ102V	1/8W 1K OHM	5REAG01738		
R25	RESISTOR FXD	ERJ-8GEYJ153V	1/8W 15K OHM	5REAG01752		
R26	RESISTOR FXD	ERJ-8GEYJ153V	1/8W 15K OHM	5REAG01752		
R27	RESISTOR FXD	ERJ-8GEYJ472V	1/8W 4.7K OHM	5REAG01746		
R28	RESISTOR FXD	ERJ-8GEYJ222V	1/8W 2.2K OHM	5REAG01742		
R29	RESISTOR FXD	ERJ-8GEYJ472V	1/8W 4.7K OHM	5REAG01746		
R30	RESISTOR FXD	ERJ-8GEYJ472V	1/8W 4.7K OHM	5REAG01746		
R31	RESISTOR FXD	ERJ-8GEYJ222V	1/8W 2.2K OHM	5REAG01742		

76

9.4 CAH-377 Power Amplifier

PARTS LIST

		TITLE		SHEET NO.	
		POWER AMPLIFIER	CAH-377	1	
PART NO	PART NAME	TYPE	DESCRIPTION	CODE	
C81	CAP,FXD ELCTLT	ECEA2AGE330	100V 33U	5CEAA02927	
FB11	CORE	HF30-BB1.8X5X0.7		5MBAA00857	
FB12	CORE	HF30-BB1.8X5X0.7		5MBAA00857	
FB13	CORE	HF30-BB1.8X5X0.7		5MBAA00857	
FB14	CORE	HF30-BB1.8X5X0.7		5MBAA00857	
FB15	CORE	HF30-BB1.8X5X0.7		5MBAA00857	
FB16	CORE	HF30-BB1.8X5X0.7		5MBAA00857	
FB21	CORE	HF30-BB1.8X5X0.7		5MBAA00857	
FB22	CORE	HF30-BB1.8X5X0.7		5MBAA00857	
FB23	CORE	HF30-BB1.8X5X0.7		5MBAA00857	
FB24	CORE	HF30-BB1.8X5X0.7		5MBAA00857	
FB25	CORE	HF30-BB1.8X5X0.7		5MBAA00857	
FB26	CORE	HF30-BB1.8X5X0.7		5MBAA00857	
FB31	CORE	HF30-BB1.8X5X0.7		5MBAA00857	
FB32	CORE	HF30-BB1.8X5X0.7		5MBAA00857	
FB33	CORE	HF30-BB1.8X5X0.7		5MBAA00857	
FB34	CORE	HF30-BB1.8X5X0.7		5MBAA00857	
FB35	CORE	HF30-BB1.8X5X0.7		5MBAA00857	
FB36	CORE	HF30-BB1.8X5X0.7		5MBAA00857	
FB41	CORE	HF30-BB1.8X5X0.7		5MBAA00857	
FB42	CORE	HF30-BB1.8X5X0.7		5MBAA00857	
FB43	CORE	HF30-BB1.8X5X0.7		5MBAA00857	
FB44	CORE	HF30-BB1.8X5X0.7		5MBAA00857	
FB45	CORE	HF30-BB1.8X5X0.7		5MBAA00857	
FB46	CORE	HF30-BB1.8X5X0.7		5MBAA00857	
J1	CONNECTOR	TMP-J01X-A2		5JWCL00045	
J2	CONNECTOR	TMP-J01X-A2		5JWCL00045	
J3	CONNECTOR	S5B-PH-K-S		5JWAP00379	
J4	CONNECTOR	1771P145-20		5JJBL00050	
J5	CONNECTOR	1771P145-20		5JJBL00050	
R1	RESISTOR FXD	ERG-2SJ680		5REAG03202	
R2	RESISTOR FXD	ERG-2SJ680		5REAG03202	
R3	RESISTOR FXD	ERG-2SJ680		5REAG03202	
R4	RESISTOR FXD	ERG-2SJ680		5REAG03202	
R11	RESISTOR FXD	ERD-50TJ270	1/2W 27 OHM	5RDAAA00797	

PARTS LIST

		TITLE		SHEET NO.	
		PA CONTROL	CCB-367-CHIP	5	
PART NO	PART NAME	TYPE	DESCRIPTION	CODE	
RV1	RESISTOR VAR	ST-4TB501		5RVAL00022	
RV2	RESISTOR VAR	ST-4TB501		5RVAL00022	
RV3	RESISTOR VAR	ST-4TB502	1/4W 5K OHM	5RVAL00028	
RV11	RESISTOR VAR	ST-4TB 2K OHM		5RVAL00050	
RV12	RESISTOR VAR	ST-4TB 2K OHM		5RVAL00050	
RV13	RESISTOR VAR	ST-4TB 2K OHM		5RVAL00050	
RV14	RESISTOR VAR	ST-4TB 2K OHM		5RVAL00050	
RV21	RESISTOR VAR	ST-4TB 2K OHM		5RVAL00050	
RV22	RESISTOR VAR	ST-4TB 2K OHM		5RVAL00050	
RV23	RESISTOR VAR	ST-4TB 2K OHM		5RVAL00050	
RV24	RESISTOR VAR	ST-4TB 2K OHM		5RVAL00050	
TR4	TRANSISTOR	2SC2873Y-TE12L		5TCAF00658	

77

35

PARTS LIST

PARTS LIST					SHEET NO.
POWER AMPLIFIER				TITLE	3
POWER AMPLIFIER				CAH-377	
PART NO	PART NAME	TYPE	DESCRIPTION	CODE	
R47	RESISTOR FXD	ERG-2SJ150		5REAG02634	
R48	RESISTOR FXD	ERG-2SJ150		5REAG02634	
R49	RESISTOR FXD	ERG-2SJ150		5REAG02634	
R50	RESISTOR FXD	ERG-2SJ150		5REAG02634	
R61	RESISTOR FXD	ERG-2SJ680		5REAG03202	
R62	RESISTOR FXD	ERG-2SJ680		5REAG03202	
R63	RESISTOR FXD	ERG-2SJ680		5REAG03202	
R64	RESISTOR FXD	ERG-2SJ680		5REAG03202	
T1	RF XFMR	H-6LHED00349A		6LHED00349	
T2	RF XFMR	H-6LHED00349A		6LHED00349	
T3	RF XFMR	H-6LHED00351A		6LHED00351	
T4	RF XFMR	H-6LHED00351A		6LHED00351	
T11	RF XFMR	H-6LHED00350A		6LHED00350	
T21	RF XFMR	H-6LHED00350A		6LHED00350	
T31	RF XFMR	H-6LHED00350A		6LHED00350	
T41	RF XFMR	H-6LHED00350A		6LHED00350	
TB1	TERMINAL	PB-1-S		5JTCW00028	
TB2	TERMINAL	PB-1-S		5JTCW00028	

PARTS LIST

PARTS LIST					SHEET NO.
POWER AMPLIFIER				TITLE	2
POWER AMPLIFIER				CAH-377	
PART NO	PART NAME	TYPE	DESCRIPTION	CODE	
R12	RESISTOR FXD	ERD-50TJ270	1/2W 27 OHM	5RDAA00797	
R13	RESISTOR FXD	ERD-50TJ270	1/2W 27 OHM	5RDAA00797	
R14	RESISTOR FXD	ERD-50TJ270	1/2W 27 OHM	5RDAA00797	
R15	RESISTOR FXD	ERD-50TJ270	1/2W 27 OHM	5RDAA00797	
R16	RESISTOR FXD	ERD-50TJ270	1/2W 27 OHM	5RDAA00797	
R17	RESISTOR FXD	ERG-2SJ150		5REAG02634	
R18	RESISTOR FXD	ERG-2SJ150		5REAG02634	
R19	RESISTOR FXD	ERG-2SJ150		5REAG02634	
R20	RESISTOR FXD	ERG-2SJ150		5REAG02634	
R21	RESISTOR FXD	ERD-50TJ270	1/2W 27 OHM	5RDAA00797	
R22	RESISTOR FXD	ERD-50TJ270	1/2W 27 OHM	5RDAA00797	
R23	RESISTOR FXD	ERD-50TJ270	1/2W 27 OHM	5RDAA00797	
R24	RESISTOR FXD	ERD-50TJ270	1/2W 27 OHM	5RDAA00797	
R25	RESISTOR FXD	ERD-50TJ270	1/2W 27 OHM	5RDAA00797	
R26	RESISTOR FXD	ERD-50TJ270	1/2W 27 OHM	5RDAA00797	
R27	RESISTOR FXD	ERG-2SJ150		5REAG02634	
R28	RESISTOR FXD	ERG-2SJ150		5REAG02634	
R29	RESISTOR FXD	ERG-2SJ150		5REAG02634	
R30	RESISTOR FXD	ERG-2SJ150		5REAG02634	
R31	RESISTOR FXD	ERD-50TJ270	1/2W 27 OHM	5RDAA00797	
R32	RESISTOR FXD	ERD-50TJ270	1/2W 27 OHM	5RDAA00797	
R33	RESISTOR FXD	ERD-50TJ270	1/2W 27 OHM	5RDAA00797	
R34	RESISTOR FXD	ERD-50TJ270	1/2W 27 OHM	5RDAA00797	
R35	RESISTOR FXD	ERD-50TJ270	1/2W 27 OHM	5RDAA00797	
R36	RESISTOR FXD	ERD-50TJ270	1/2W 27 OHM	5RDAA00797	
R37	RESISTOR FXD	ERG-2SJ150		5REAG02634	
R38	RESISTOR FXD	ERG-2SJ150		5REAG02634	
R39	RESISTOR FXD	ERG-2SJ150		5REAG02634	
R40	RESISTOR FXD	ERG-2SJ150		5REAG02634	
R41	RESISTOR FXD	ERD-50TJ270	1/2W 27 OHM	5RDAA00797	
R42	RESISTOR FXD	ERD-50TJ270	1/2W 27 OHM	5RDAA00797	
R43	RESISTOR FXD	ERD-50TJ270	1/2W 27 OHM	5RDAA00797	
R44	RESISTOR FXD	ERD-50TJ270	1/2W 27 OHM	5RDAA00797	
R45	RESISTOR FXD	ERD-50TJ270	1/2W 27 OHM	5RDAA00797	
R46	RESISTOR FXD	ERD-50TJ270	1/2W 27 OHM	5RDAA00797	

PARTS LIST

		POWER AMPLIFIER		TITLE	CAH-377-CHIP	SHEET NO.
						2
PART NO	PART NAME	TYPE	DESCRIPTION	CODE		
C72	CAP,FXD C CER	C3216JF1H104Z-E-TP	50V 0.1UF	5CAAD01268		
C73	CAP,FXD C CER	C3216JF1H104Z-E-TP	50V 0.1UF	5CAAD01268		
C74	CAP,FXD C CER	C3216JF1H104Z-E-TP	50V 0.1UF	5CAAD01268		
C91	CAP,FXD CER	C3216CH1H391J-E-TP	390P	5CAAD00786		
C92	CAP,FXD CER	C3216CH1H391J-E-TP	390P	5CAAD00786		
C93	CAP,FXD CER	C3216CH1H391J-E-TP	390P	5CAAD00786		
C94	CAP,FXD CER	C3216CH1H391J-E-TP	390P	5CAAD00786		
PC1	PCB	H-6PCED00912E	CAH-377	6PCED00912		
R5	RESISTOR FXD	ERJ-8GEYJ103V	1/8W 10K OHM	5REAG01750		
R6	RESISTOR FXD	ERJ-8GEYJ103V	1/8W 10K OHM	5REAG01750		
R7	RESISTOR FXD	ERJ-8GEYJ103V	1/8W 10K OHM	5REAG01750		
R8	RESISTOR FXD	ERJ-8GEYJ103V	1/8W 10K OHM	5REAG01750		

PARTS LIST

		POWER AMPLIFIER		TITLE	CAH-377-CHIP	SHEET NO.
						1
PART NO	PART NAME	TYPE	DESCRIPTION	CODE		
C1	CAP,FXD CER	C3216SL1H222J-E-TP	2200PF	5CAAD00792		
C2	CAP,FXD CER	C3216SL1H222J-E-TP	2200PF	5CAAD00792		
C3	CAP,FXD CER	C3216SL1H222J-E-TP	2200PF	5CAAD00792		
C4	CAP,FXD CER	C3216SL1H222J-E-TP	2200PF	5CAAD00792		
C5	CAP,FXD CER	C3216CH1H471J-E-TP	470PF	5CAAD00797		
C7	CAP,FXD CER	C3216CH1H471J-E-TP	470PF	5CAAD00797		
C9	CAP,FXD CER	C5650X7R1H474K-TP	50V 0.47UF	5CAAD01993		
C10	CAP,FXD CER	C5650X7R1H474K-TP	50V 0.47UF	5CAAD01993		
C11	CAP,FXD CER	C5650X7R1H474K-TP	50V 0.47UF	5CAAD01993		
C12	CAP,FXD TANTAL	267M1002 685ML	6.8U 10V	5CSAC01410		
C13	CAP,FXD TANTAL	267M1002 685ML	6.8U 10V	5CSAC01410		
C14	CAP,FXD CER	C5650X7R2A334K-TP	100V 0.33UF	5CAAD01994		
C15	CAP,FXD CER	C5650X7R2A334K-TP	100V 0.33UF	5CAAD01994		
C16	CAP,FXD CER	C5650X7R2A334K-TP	100V 0.33UF	5CAAD01994		
C17	CAP,FXD CER	C5650X7R2A334K-TP	100V 0.33UF	5CAAD01994		
C18	CAP,FXD CER	C5650X7R2A334K-TP	100V 0.33UF	5CAAD01994		
C19	CAP,FXD CER	C5650X7R2A334K-TP	100V 0.33UF	5CAAD01994		
C21	CAP,FXD CER	C5650X7R1H474K-TP	50V 0.47UF	5CAAD01993		
C22	CAP,FXD TANTAL	267M1002 685ML	6.8U 10V	5CSAC01410		
C23	CAP,FXD TANTAL	267M1002 685ML	6.8U 10V	5CSAC01410		
C24	CAP,FXD CER	C5650X7R2A334K-TP	100V 0.33UF	5CAAD01994		
C25	CAP,FXD CER	C5650X7R2A334K-TP	100V 0.33UF	5CAAD01994		
C26	CAP,FXD CER	C5650X7R2A334K-TP	100V 0.33UF	5CAAD01994		
C27	CAP,FXD CER	C5650X7R2A334K-TP	100V 0.33UF	5CAAD01994		
C28	CAP,FXD CER	C5650X7R2A334K-TP	100V 0.33UF	5CAAD01994		
C29	CAP,FXD CER	C5650X7R2A334K-TP	100V 0.33UF	5CAAD01994		
C31	CAP,FXD CER	C5650X7R1H474K-TP	50V 0.47UF	5CAAD01993		
C32	CAP,FXD TANTAL	267M1002 685ML	6.8U 10V	5CSAC01410		
C33	CAP,FXD TANTAL	267M1002 685ML	6.8U 10V	5CSAC01410		
C41	CAP,FXD CER	C5650X7R1H474K-TP	50V 0.47UF	5CAAD01993		
C42	CAP,FXD TANTAL	267M1002 685ML	6.8U 10V	5CSAC01410		
C43	CAP,FXD TANTAL	267M1002 685ML	6.8U 10V	5CSAC01410		
C54	CAP,FXD MICA	UC232H0470J TAPE TYP	500V 47PF	5CMAB01252		
C64	CAP,FXD MICA	UC232H0470J TAPE TYP	500V 47PF	5CMAB01252		
C71	CAP,FXD C CER	C3216JF1H104Z-E-TP	50V 0.1UF	5CAAD01268		

79

15

20

25

30

35

35

9.5 CFF-361 Power Combiner

PARTS LIST

POWER COMBINER					TITLE	SHEET NO.
					CFF-361	2
PART NO	PART NAME	TYPE	DESCRIPTION	CODE		
R54	RESISTOR FXD	ERD-50TJ180	1/2W 18 OHM	5RDAA00793		
T1	RF XFMR	H-6LHED00360A		6LHED00360		
T2	RF XFMR	H-6LHED00360A		6LHED00360		
T3	RF XFMR	H-6LHED00359A		6LHED00359		
T4	RF XFMR	H-6LHED00362A		6LHED00362		
T5	RF XFMR	H-6LHED00364A		6LHED00364		
W1	COAXIAL CABLE	DFS040		2663111115		
W231	CABLE	H-6ZCED00311A	2.5D-2V	6ZCED00311		
W232	CABLE	H-6ZCED00311A	2.5D-2V	6ZCED00311		
W233	CABLE	H-6ZCED00311A	2.5D-2V	6ZCED00311		
W234	CABLE	H-6ZCED00311A	2.5D-2V	6ZCED00311		
W307	COAXIAL CABLE	5D-2V		2661111161		

PARTS LIST

POWER COMBINER					TITLE	SHEET NO.
					CFF-361	1
PART NO	PART NAME	TYPE	DESCRIPTION	CODE		
C1	CAP,FXD	CER	CC45CH2H050DY	500V 5PF	5CAAB00962	
C2	CAP,FXD	CER	RPE131CH471K50	470P	5CAAA02860	
C3	CAP,FXD	CER	CC45CH2H050DY	500V 5PF	5CAAB00962	
C4	CAP,FXD	CER	RPE131CH471K50	470P	5CAAA02860	
C5	CAP,FXD	CER	DD112B103K50	50V 10000PF	5CBAB00403	
C7	CAP,FXD	CER	DD112B103K50	50V 10000PF	5CBAB00403	
C8	CAP,FXD	CER	DD112B103K50	50V 10000PF	5CBAB00403	
C9	CAP,FXD	CER	DD112B103K50	50V 10000PF	5CBAB00403	
C10	CAP,FXD	CER	DD112B103K50	50V 10000PF	5CBAB00403	
C14	CAP,FXD	MICA	DM19C330J5		5CMAB01341	
C15	CAP,FXD	MICA	DM19C330J5		5CMAB01341	
CD1	DIODE		1S1585		5TXAD00038	
CD2	DIODE		1S1585		5TXAD00038	
CD3	DIODE		1S1585		5TXAD00038	
CD11	DIODE		31DF4	400V 3A	5TXAG00254	
CD12	DIODE		31DF4	400V 3A	5TXAG00254	
CD13	ARRESTER		Z6150U		5ZAAM00015	
CD14	ARRESTER		Z6150U		5ZAAM00015	
CD15	ARRESTER		Z6150U		5ZAAM00015	
CD16	ARRESTER		Z6150U		5ZAAM00015	
J203	PIN JACK		TMP-J01X-V6		5JWCL00058	
J204	CONNECTOR		B8B-PH-K-S		5JWAP00389	
K4	RELAY		G2R-1-E DC12V		5KLAFF00696	
L1	COIL		LAL04NA101K		5LCAA00202	
L2	COIL		LAL04NA101K		5LCAA00202	
L3	COIL		LAL04NA101K		5LCAA00202	
L4	COIL		LAL04NA101K		5LCAA00202	
PC1	PCB		H-6PCED00906D	CFF-361	6PCED00906	
R1	RESISTOR FXD		ERG-5CJ101		5RAAD00021	
R2	RESISTOR FXD		ERG-5CJ101		5RAAD00021	
R3	RESISTOR		ER10SP50 OHM K	50 OHM	5RZAA00071	
R7	POSISTOR		PTH487A01BE222TS		5RXAE00028	
R51	RESISTOR FXD		ERD-50TJ180	1/2W 18 OHM	5RDAA00793	
R52	RESISTOR FXD		ERD-50TJ180	1/2W 18 OHM	5RDAA00793	
R53	RESISTOR FXD		ERD-50TJ180	1/2W 18 OHM	5RDAA00793	

80

15

20

25

30

35

15

20

25

30

35

PARTS LIST

POWER SUPPLY				TITLE	SHEET NO.
				NBL-169	2
PART NO	PART NAME	TYPE	DESCRIPTION	CODE	
SP4	SHEET	BFG-30,D-3		5ZKBA00021	
SP5	THERMAL SHEET	BFG-30 D-1	T0-220	5ZKBA00013	
SP6	THERMAL SHEET	BFG-30 D-1	T0-220	5ZKBA00013	
SP7	THERMAL SHEET	BFG-30 D-1	T0-220	5ZKBA00013	
SP201	SHEET	BFG-30,D-3		5ZKBA00021	
SP202	SHEET	BFG-30,D-3		5ZKBA00021	
SP203	SHEET	BFG-30,D-3		5ZKBA00021	
SP204	SHEET	BFG-30,D-3		5ZKBA00021	
SP205	SHEET	BFG-30,D-3		5ZKBA00021	
SP206	SHEET	BFG-30,D-3		5ZKBA00021	
SP207	THERMAL SHEET	BFG-30 D-1	T0-220	5ZKBA00013	
SP208	THERMAL SHEET	BFG-30 D-1	T0-220	5ZKBA00013	
SP209	THERMAL SHEET	BFG-30 D-1	T0-220	5ZKBA00013	
SP210	THERMAL SHEET	BFG-30 D-1	T0-220	5ZKBA00013	
T201	PULSE XFMR	H-6LPE000010B		6LPE000010	
TR1	TRANSISTOR	2SK1250	500V 20A	5TKAX00001	
TR2	TRANSISTOR	2SK1250	500V 20A	5TKAX00001	
TR3	TRANSISTOR	2SK1250	500V 20A	5TKAX00001	
TR6	FET	IRF9530		5TZBE00049	
TR7	FET	IRF9530		5TZBE00049	
TR201	TRANSISTOR	2SK1250	500V 20A	5TKAX00001	
TR202	TRANSISTOR	2SK1250	500V 20A	5TKAX00001	
TR203	TRANSISTOR	2SK1250	500V 20A	5TKAX00001	
TR204	TRANSISTOR	2SK1250	500V 20A	5TKAX00001	
TS201	SWITCH	5003S-45°CM-1 UL		5SXAH00043	
W18	CABLE	H-6ZCED00305		6ZCED00305	
W501	CABLE	H-6ZCED13007		6ZCED13007	
W701	CABLE	VFF2X37/0.26-(20)		2233102002	
W702	WIRE	250V-HV-37/0.26-(9)	H-6486-1	2265100938	

PARTS LIST

POWER SUPPLY				TITLE	SHEET NO.
				NBL-169	1
PART NO	PART NAME	TYPE	DESCRIPTION	CODE	
B1	FAN	109P 1212H-1021		5BFAB00231	
BG1	FAN	109-019C		5BFAB00023	
BS1	ACCESSORY	AC316A		5ZKAH00026	
BS2	ACCESSORY	AC316A		5ZKAH00026	
C71	CAP,FXD	PLSTC 30FAEN50SUJA(E)		5CRAK00053	
C72-1	CAP,FXD	CER DD18B103K500	500V 10000PF	5CBAB00884	
C72-2	CAP,FXD	CER DD18B103K500	500V 10000PF	5CBAB00884	
C72-3	CAP,FXD	CER DD18B103K500	500V 10000PF	5CBAB00884	
C203	CAP,FXD	PLSTC MTB-2G-335K		5CRBF00002	
C242	CAP,FXD	PLSTC ECQ-V1H474JZ	50V 0.47UF	5CRAA00419	
CD1	DIODE	S15VB60	600V 15A	5TXAC00136	
CD2	DIODE	30KF50B		5TXAG00296	
CD7	DIODE	D10SC6M		5TXAC00238	
CD301	DIODE	30KF50B		5TXAG00296	
CD302	DIODE	30KF50B		5TXAG00296	
FL1	FILTER	GT-22001V	250V 20A	5NLAE00068	
FL2	FILTER	GT-22001V	250V 20A	5NLAE00068	
L1	COIL	H-6LGED000005		6LGED000005	
L2	COIL	H-6LGED000005		6LGED000005	
L201	COIL	H-6LGED000004A		6LGED000004	
P503	CONNECTOR	HNC2-2.5S-2	2P	5JDA000279	
P503C	CONTACT	HNC-2.5S-D-B		5JDA000408	
PS1	PS UNIT	FY124R6KA		5ZGAE00003	
R1	RESISTOR FXD	CRH80V30 OHM JOS		5RHAA03077	
R2	RESISTOR FXD	RNP-10C 24 OHM F		5REBB00015	
R31	RESISTOR FXD	RE70G10K OHM J		5RHAA01158	
R209	RESISTOR FXD	RE75G390 OHM J		5RHAA03109	
R301	RESISTOR FXD	RNP-10C 24 OHM F		5REBB00015	
R302	RESISTOR FXD	RNP-10C 24 OHM F		5REBB00015	
R303	RESISTOR FXD	RNP-10C 24 OHM F		5REBB00015	
R304	RESISTOR FXD	RNP-10C 24 OHM F		5REBB00015	
RV201	RESISTOR VAR	RV16YN10SB10K OHM	10K OHM	5RVAA00009	
SP1	SHEET	BFG-30,D-3		5ZKBA00021	
SP2	SHEET	BFG-30,D-3		5ZKBA00021	
SP3	SHEET	BFG-30,D-3		5ZKBA00021	

81

35

PARTS LIST

PARTS LIST

PARTS LIST					SHEET NO.
MAIN PS UNIT				CBG-68	2
PART NO	PART NAME	TYPE	DESCRIPTION	CODE	
C237	CAP.FXD TANTAL	245M3502 105MB	34V 1UF	5CSAC00985	
C238	CAP.FXD CER	DD112B103K50	50V 10000PF	5CBAB00403	
C239	CAP.FXD CER	RPE132F104Z50	0.1UF 50V	5CBAB01631	
C240	CAP.FXD PLSTC	ECQ-V1H105JZ	1.0UFUF 50V	5CRAA00471	
C241	CAP.FXD CER	DD104B102K50	50V 1000PF	5CBAB00302	
C244	CAP.FXD PLSTC	ECQ-B1H223KZ	0.022UF	5CRAA00428	
C301	CAP.FXD CER	DD18B103K500	500V 10000PF	5CBAB00884	
C302	CAP.FXD CER	DD18B103K500	500V 10000PF	5CBAB00884	
CD201	DIODE	H114B		5TXAE00861	
CD202	DIODE	H114B		5TXAE00861	
CD203	DIODE	1S1588		5TXAD00040	
CD204	DIODE	1S1588		5TXAD00040	
CD205	DIODE	1S1588		5TXAD00040	
CD206	DIODE	1S1588		5TXAD00040	
CD207	DIODE	1S1588		5TXAD00040	
CD208	DIODE	1S1588		5TXAD00040	
CD209	DIODE	1S1588		5TXAD00040	
CD210	DIODE	1S1588		5TXAD00040	
CD211	DIODE	RG4C		5TXAN00165	
CD212	DIODE	RG4C		5TXAN00165	
CD213	DIODE	HZ5C1	5V 1/2W	5TXAE00130	
CD214	DIODE	HZ5C1	5V 1/2W	5TXAE00130	
CD215	DIODE	1S1588		5TXAD00040	
CD216	DIODE	HZ5C1	5V 1/2W	5TXAE00130	
CD217	DIODE	1S1588		5TXAD00040	
CD218	DIODE	1S1588		5TXAD00040	
CD303	DIODE	RG4C		5TXAN00165	
CD304	DIODE	RG4C		5TXAN00165	
IC201	IC	TL594CN		5DDAL01159	
IC202	IC	OP-07DP		5DDAL01109	
IC203	IC	NJM2901N		5DAAN00006	
J506	CONNECTOR	B11B-PH-K-S		5JWAP00390	
PC1	PCB	H-6PCED00900E		6PCED00900	
R201	RESISTOR FXD	ERD-25PJ4R7	1/4W 4.7 OHM	5RDAAO1203	
R202	RESISTOR FXD	ERD-25PJ4R7	1/4W 4.7 OHM	5RDAAO1203	

PARTS LIST					SHEET NO.
MAIN PS UNIT				CBG-68	1
PART NO	PART NAME	TYPE	DESCRIPTION	CODE	
C201-1	CAP.FXD ELCTLT	KMH450VNSN470 35F	450V 470UF	5CEAP00166	
C201-2	CAP.FXD CER	DD18B103K500	500V 10000PF	5CBAB00884	
C202	CAP.FXD PLSTC	MTB-2G-335K		5CRBF00002	
C204	CAP.FXD MICA	DM19C102J5	500WV 1000PF	5CMAB00145	
C205	CAP.FXD MICA	DM19C102J5	500WV 1000PF	5CMAB00145	
C206-1	CAP.FXD ELCTLT	RZA100VH-820 25D	100V 820UF	5CEAP00143	
C206-2	CAP.FXD ELCTLT	RZA100VH-820 25D	100V 820UF	5CEAP00143	
C208-1	CAP.FXD MP	431A2003 104K	200V 0.1UF	5CHAD00066	
C208-2	CAP.FXD CER	DD18B103K500	500V 10000PF	5CBAB00884	
C209	CAP.FXD CER	DD107CH101J50	50V 100PF	5CAA00858	
C210	CAP.FXD TANTAL	202L2502 475K4	25V 4.7UF	5CSAC00344	
C211	CAP.FXD CER	RPE132F104Z50	0.1UF 50V	5CBAB01631	
C212	CAP.FXD CER	RPE132F104Z50	0.1UF 50V	5CBAB01631	
C213	CAP.FXD CER	DD112SL102J50	50V 1000PF	5CAA01112	
C214	CAP.FXD PLSTC	ECQ-B1H223KZ	0.022UF	5CRAA00428	
C216	CAP.FXD CER	RPE132F104Z50	0.1UF 50V	5CBAB01631	
C217	CAP.FXD ELCTLT	ECE-A1EU221	220UF 25V	5CEAA01844	
C218	CAP.FXD TANTAL	202L3502 475K4	4.7UF 35V	5CSAC00322	
C219	CAP.FXD CER	RPE132F104Z50	0.1UF 50V	5CBAB01631	
C220	CAP.FXD CER	RPE132F104Z50	0.1UF 50V	5CBAB01631	
C221	CAP.FXD CER	RPE132F104Z50	0.1UF 50V	5CBAB01631	
C222	CAP.FXD CER	RPE132F104Z50	0.1UF 50V	5CBAB01631	
C223	CAP.FXD CER	RPE132F104Z50	0.1UF 50V	5CBAB01631	
C224	CAP.FXD CER	RPE132F104Z50	0.1UF 50V	5CBAB01631	
C225	CAP.FXD CER	RPE132F104Z50	0.1UF 50V	5CBAB01631	
C226	CAP.FXD CER	RPE132F104Z50	0.1UF 50V	5CBAB01631	
C227	CAP.FXD TANTAL	245M3502 105MB	34V 1UF	5CSAC00985	
C228	CAP.FXD CER	RPE132F104Z50	0.1UF 50V	5CBAB01631	
C229	CAP.FXD CER	RPE132F104Z50	0.1UF 50V	5CBAB01631	
C230	CAP.FXD CER	RPE132F104Z50	0.1UF 50V	5CBAB01631	
C232	CAP.FXD CER	RPE132F104Z50	0.1UF 50V	5CBAB01631	
C233	CAP.FXD CER	RPE132F104Z50	0.1UF 50V	5CBAB01631	
C234	CAP.FXD CER	RPE132F104Z50	0.1UF 50V	5CBAB01631	
C235	CAP.FXD CER	RPE132F104Z50	0.1UF 50V	5CBAB01631	
C236	CAP.FXD ELCTLT	ECE-A1EU101	25V 100UF	5CEAA01839	

82

PARTS LIST

			TITLE		SHEET NO.
			MAIN PS UNIT	CBG-68	4
PART NO	PART NAME	TYPE	DESCRIPTION	CODE	
R243	RESISTOR FXD	ERD-25UJ242	1/4W 2.4K OHM	5RDAA01354	
R245	RESISTOR FXD	RE35-YQ-200 OHM F		5READ00217	
R246	RESISTOR FXD	RE35-YQ-1.8K OHM F	1/4W 1.8K OHM	5READ00495	
R247	RESISTOR FXD	ERD-25UJ333	1/4W 33K OHM	5RDAA01381	
R248	RESISTOR	ERD-25UJ152	1/4W 1.5K OHM	5RDAA01349	
R249	RESISTOR FXD	ERD-25UJ224	1/4W 220K OHM	5RDAA01401	
R250	RESISTOR FXD	RE15-YQ-8.2K OHM F	1/8W 8.2K OHM	5READ00510	
R251	RESISTOR FXD	RE15-YQ-2.2K OHM F	1/8W 2.2K OHM	5READ00500	
R252	RESISTOR FXD	ERD-25UJ682	1/4W 6.8K OHM	5RDAA01365	
R253	RESISTOR FXD	ERD-25UJ682	1/4W 6.8K OHM	5RDAA01365	
R254	RESISTOR FXD	ERD-25UJ682	1/4W 6.8K OHM	5RDAA01365	
R255	RESISTOR FXD	ERD-25UJ103	1/4W 10K OHM	5RDAA01369	
R256	RESISTOR FXD	ERD-25UJ103	1/4W 10K OHM	5RDAA01369	
R257	RESISTOR FXD	ERD-25UJ472	1/4W 4.7K OHM	5RDAA01361	
R258	RESISTOR	ERD-25UJ152	1/4W 1.5K OHM	5RDAA01349	
R259	RESISTOR FXD	ERD-25UJ473	1/4W 47K OHM	5RDAA01385	
R260	RESISTOR FXD	ERD-25UJ224	1/4W 220K OHM	5RDAA01401	
R261	RESISTOR FXD	ERD-25UJ4R7	1/4W 4.7 OHM	5RDAA01289	
R262	RESISTOR FXD	ERG-2ANJ100	2W 10 OHM	5REAG00048	
R263	RESISTOR FXD	ERD-25UJ103	1/4W 10K OHM	5RDAA01369	
R305	RESISTOR FXD	ERG-3ANJ473		5REAG01480	
R306	RESISTOR FXD	ERG-3ANJ473		5REAG01480	
RV202	RESISTOR VAR	EVN-D8AA03B54		5RVAB00419	
T202	PULSE XFMR	H-6LPED00011B		6LPED00011	
T203	PULSE XFMR	H-6LPED00011B		6LPED00011	
TE201	TERMINAL	PB-1-S		5JTCW00028	
TE202	TERMINAL	PB-1-S		5JTCW00028	
TE203	TERMINAL	PB-1-S		5JTCW00028	
TE204	TERMINAL	PB-1-S		5JTCW00028	
TE205	TERMINAL	PB-1-S		5JTCW00028	
TE206	TERMINAL	PB-1-S		5JTCW00028	
TE207	TERMINAL	PB-1-S		5JTCW00028	
TE208	TERMINAL	PB-1-S		5JTCW00028	
TE209	TERMINAL	PB-1-S		5JTCW00028	
TE210	TERMINAL	PB-1-S		5JTCW00028	

PARTS LIST

			TITLE		SHEET NO.
			MAIN PS UNIT	CBG-68	3
PART NO	PART NAME	TYPE	DESCRIPTION	CODE	
R203	RESISTOR FXD	ERD-25PJ4R7	1/4W 4.7 OHM	5RDAA01203	
R204	RESISTOR FXD	ERD-25PJ4R7	1/4W 4.7 OHM	5RDAA01203	
R205	RESISTOR FXD	ERD-50TJ680	1/2W 68 OHM	5RDAA00807	
R206	RESISTOR FXD	ERD-50TJ680	1/2W 68 OHM	5RDAA00807	
R207	RESISTOR FXD	ERD-50TJ680	1/2W 68 OHM	5RDAA00807	
R208	RESISTOR FXD	ERD-50TJ680	1/2W 68 OHM	5RDAA00807	
R211	RESISTOR FXD	ERD-25UJ103	1/4W 10K OHM	5RDAA01369	
R213	RESISTOR FXD	ERD-50TJ680	1/2W 68 OHM	5RDAA00807	
R214	RESISTOR FXD	ERD-50TJ680	1/2W 68 OHM	5RDAA00807	
R215	RESISTOR FXD	ERD-25UJ122	1/4W 1.2K OHM	5RDAA01347	
R216	RESISTOR FXD	ERD-25UJ122	1/4W 1.2K OHM	5RDAA01347	
R217	RESISTOR FXD	ERD-25UJ303	1/4W 30K OHM	5RDAA01380	
R219	RESISTOR FXD	RE15-YQ-1.6K OHM F	1/8W 1.6K OHM	5READ00590	
R220	RESISTOR FXD	RE15-YQ-3.3K OHM F	1/8W 3.3K OHM	5READ00556	
R221	RESISTOR FXD	ERD-25UJ471	1/4W 470 OHM	5RDAA01337	
R222	RESISTOR FXD	ERD-25UJ202	1/4W 2K OHM	5RDAA01352	
R223	RESISTOR FXD	ERD-25UJ105	1/4W 1M OHM	5RDAA01417	
R224	RESISTOR FXD	ERD-25UJ473	1/4W 47K OHM	5RDAA01385	
R225	RESISTOR FXD	ERD-25UJ222	1/4W 2.2K OHM	5RDAA01353	
R226	RESISTOR FXD	ERD-25UJ471	1/4W 470 OHM	5RDAA01337	
R227	RESISTOR FXD	ERD-25UJ202	1/4W 2K OHM	5RDAA01352	
R228	RESISTOR FXD	ERD-25UJ103	1/4W 10K OHM	5RDAA01369	
R229	RESISTOR FXD	ERD-25UJ824	1/4W 820K OHM	5RDAA01415	
R230	RESISTOR FXD	ERD-25UJ513	1/4W 51K OHM	5RDAA01386	
R231	RESISTOR FXD	TS6 0.004 OHM J		5RHA03056	
R232	POSISTOR	PTH9M04BF222TS 2F333		5RXAE00084	
R233	RESISTOR FXD	RE35-YQ-10K OHM F	1/4W 10K OHM	5READ00655	
R234	RESISTOR FXD	RE35-YQ-10K OHM F	1/4W 10K OHM	5READ00655	
R235	RESISTOR FXD	RE35-YQ-2K OHM F	1/4W 2K OHM	5READ00199	
R236	RESISTOR FXD	RE35-YQ-15K OHM F	1/4W 15K OHM	5READ00276	
R237	RESISTOR FXD	RE35-YQ-12K OHM F	1/4W 12K OHM	5READ00278	
R238	RESISTOR FXD	RE35-YQ-1.5K OHM F	1/4W 1.5K OHM	5READ00145	
R240	RESISTOR FXD	RE15-YQ-3.3K OHM F	1/8W 3.3K OHM	5READ00556	
R241	RESISTOR FXD	ERD-25UJ103	1/4W 10K OHM	5RDAA01369	
R242	RESISTOR	ERD-25UJ152	1/4W 1.5K OHM	5RDAA01349	

PARTS LIST

		POWER FACTOR PS			TITLE	SHEET NO.
					CBB-13	1
PART NO	PART NAME	TYPE	DESCRIPTION	CODE		
C1-1	CAP,FXD CER	DD18B103K500	500V 1000PF	5CBAB00884		
C1-2	CAP,FXD CER	DD18B103K500	500V 1000PF	5CBAB00884		
C1-3	CAP,FXD CER	DD18B103K500	500V 1000PF	5CBAB00884		
C2	CAP,FXD PLSTC	MTB-2G-335K		5CRBF00002		
C3	CAP,FXD ELCTLT	KMH450VNSN470 35F	450V 470UF	5CEAP00166		
C4	CAP,FXD CER	TCC45CH2H910JYA		5CAAB02041		
C5	CAP,FXD PLSTC	MDDSA-2E-474K		5CRBH00001		
C6	CAP,FXD CER	DD104B102K50	50V 1000PF	5CBAB00302		
C7	CAP,FXD PLSTC	ECQ-V1H105JZ	1.0UFUF 50V	5CRAA00471		
C9	CAP,FXD PLSTC	ECQ-V1H105JZ	1.0UFUF 50V	5CRAA00471		
C10	CAP,FXD PLSTC	ECQ-V1H105JZ	1.0UFUF 50V	5CRAA00471		
C11	CAP,FXD PLSTC	ECQ-B1H332KZ	0.0033UF	5CRAA00527		
C12	CAP,FXD CER	RPE132F104Z50	0.1UF 50V	5CBAB01631		
C13	CAP,FXD ELCTLT	ECE-A1EU101	25V 100UF	5CEAA01839		
C14	CAP,FXD MICA	DM19C102J5	500WV 1000PF	5CMAB00145		
C15	CAP,FXD PLSTC	ECQ-B1H222KZ	50V 2200PF	5CRAA00429		
C16	CAP,FXD CER	RPE132F104Z50	0.1UF 50V	5CBAB01631		
C25	CAP,FXD PLSTC	ECQ-V1H474JZ	50V 0.47UF	5CRAA00419		
C52	CAP,FXD PLSTC	ECQ-V1H105JZ	1.0UFUF 50V	5CRAA00471		
C62	CAP,FXD ELCTLT	ECE-A1EU101	25V 100UF	5CEAA01839		
C63	CAP,FXD CER	RPE132F104Z50	0.1UF 50V	5CBAB01631		
C64	CAP,FXD CER	RPE132F104Z50	0.1UF 50V	5CBAB01631		
C65	CAP,FXD CER	RPE132F104Z50	0.1UF 50V	5CBAB01631		
C66	CAP,FXD CER	RPE132F104Z50	0.1UF 50V	5CBAB01631		
C68	CAP,FXD CER	RPE132F104Z50	0.1UF 50V	5CBAB01631		
C69	CAP,FXD CER	RPE132F104Z50	0.1UF 50V	5CBAB01631		
C70	CAP,FXD CER	RPE132F104Z50	0.1UF 50V	5CBAB01631		
C72	CAP,FXD CER	DD104B102K50	50V 1000PF	5CBAB00302		
C73	CAP,FXD CER	DD106F103Z50	50V 10000PF	5CBAB00400		
C74	CAP,FXD CER	DD104CH100D50	50V 10PF	5CAAA00846		
C75	CAP,FXD CER	DD104CH050C50	50V 5PF	5CAAA00844		
C76	CAP,FXD CER	DD104SL330J50	50V 33PF	5CAAA01095		
CD3-1	DIODE	RG4C		5TXAN00165		
CD3-2	DIODE	RG4C		5TXAN00165		
CD4	PHOTOCOUPLER	TLP521-1-A		5TZAD00197		

9.8 CBB-13 Power Factor Corrector

PARTS LIST

		MAIN PS UNIT			TITLE	SHEET NO.
					CBB-68	5
PART NO	PART NAME	TYPE	DESCRIPTION	CODE		
TP201	TERMINAL	CP-8		5JTBV00005		
TP202	TERMINAL	CP-8		5JTBV00005		
TP203	TERMINAL	CP-8		5JTBV00005		
TP204	TERMINAL	CP-8		5JTBV00005		
TR205	FET	IRFU120		5TZBE00052		
TR206	FET	IRFU120		5TZBE00052		
TR207	TRANSISTOR	2SA1020		5TAAG00146		
TR208	TRANSISTOR	2SA1020		5TAAG00146		
TR209	TRANSISTOR	2SC1815		5TCAF00441		
TR210	TRANSISTOR	2SC1815		5TCAF00441		
TR211	TRANSISTOR	2SC2655		5TCAF00301		
TR212	TRANSISTOR	2SA1020		5TAAG00146		

PARTS LIST

PARTS LIST

		POWER FACTDR PS		TITLE	CBB-13	SHEET NO.
						3
PART NO	PART NAME	TYPE	DESCRIPTION	CODE		
R25	RESISTOR FXD	RTL1/4C3-215K OHM F		5REAA05556		
R26	RESISTOR FXD	RTL1/4C3-215K OHM F		5REAA05556		
R27	RESISTOR FXD	RE35-YQ-6.2K OHM F		5READ00153		
R28	RESISTOR FXD	ERD-25UJ103	1/4W 10K OHM	5RDAAD1369		
R29	RESISTOR FXD	ERD-25UJ472	1/4W 4.7K OHM	5RDAAD1361		
R30	POSISTOR	PTH9M04BF222TS 2F333		5RXAE00084		
R32	RESISTOR FXD	ERD-25PJ152	1/4W 1.5K OHM	5RDAAD1160		
R33	RESISTOR FXD	ERD-50TJ331	1/2W 330 OHM	5RDAAD00823		
R34	RESISTOR FXD	ERD-50TJ331	1/2W 330 OHM	5RDAAD00823		
R35	RESISTOR FXD	ERD-25UJ102	1/4W 1K OHM	5RDAAD1345		
R36	RESISTOR FXD	ERD-25UJ123	1/4W 12K OHM	5RDAAD1371		
R37	RESISTOR FXD	ERD-25UJ122	1/4W 1.2K OHM	5RDAAD1347		
R38	RESISTOR FXD	2XL0.1 OHM K	2W0.1 OHM	5RHAA00002		
R39	RESISTOR FXD	ERD-25UJ103	1/4W 10K OHM	5RDAAD1369		
T1	XFMR	H-6LZED00004A		6LZED00004		
T2	PULSE XFMR	H-6LPED00012A		6LPED00012		
TE1	TERMINAL	PB-1-S		5JTCW00028		
TE2	TERMINAL	PB-1-S		5JTCW00028		
TE3	TERMINAL	PB-1-S		5JTCW00028		
TE4	TERMINAL	PB-1-S		5JTCW00028		
TE5	TERMINAL	PB-1-S		5JTCW00028		
TE6	TERMINAL	PB-1-S		5JTCW00028		
TP1	TERMINAL	CP-8		5JTBV00005		
TP2	TERMINAL	CP-8		5JTBV00005		
TR4	TRANSISTOR	2SC2655		5TCAF00301		
TR5	TRANSISTOR	2SA1020		5TAAG00146		
TR8	TRANSISTOR	2SC2655		5TCAF00301		

		POWER FACTDR PS		TITLE	CBB-13	SHEET NO.
						2
PART NO	PART NAME	TYPE	DESCRIPTION	CODE		
CD5	DIODE	H114B		5TXAE00861		
CD6	DIODE	H114B		5TXAE00861		
CD8	DIODE	1S1588		5TXAD00040		
CD9	DIODE	H114B		5TXAE00861		
CD10	DIODE	HZ5C1	5V 1/2W	5TXAE00130		
CD11	DIODE	1S1588		5TXAD00040		
CD12	DIODE	1S1588		5TXAD00040		
IC1	IC	ML4812CP		5DADR00002		
IC2	IC	TL594CN		5DDAL01159		
IC4	IC	NJM7912FA		5DAAN00324		
IC5	IC	NJM2904L	OP AMP	5DAAN00531		
J505	CONNECTOR	S9B-PH-K-S		5JWAP00421		
K1	RELAY	G4FN-1112TP DC12V		5KLAF00676		
L11	COIL	SF-T8-50S	72UH	5LCAC00148		
L12	COIL	SF-T8-50S	72UH	5LCAC00148		
L13	COIL	SF-T8-50S	72UH	5LCAC00148		
PC1	PCB	H-6PCED00899D		6PCED00899		
R3	RESISTOR FXD	ERG-3ANJ470		5REAG01464		
R4	RESISTOR FXD	ERD-50TJ220	1/2W 22 OHM	5RDAAD00795		
R5	RESISTOR FXD	ERD-50TJ220	1/2W 22 OHM	5RDAAD00795		
R6	RESISTOR FXD	ERD-50TJ220	1/2W 22 OHM	5RDAAD00795		
R11	RESISTOR FXD	ERD-25PJ824	1/4W 820K OHM	5RDAAD1285		
R12	RESISTOR FXD	ERD-25PJ364	1/4W 360K OHM	5RDAAD1277		
R13	RESISTOR FXD	ERD-25PJ364	1/4W 360K OHM	5RDAAD1277		
R14	RESISTOR FXD	ERG-2ANJ220	22 OHM 2W	5REAG00075		
R15	RESISTOR FXD	ERD-25PJ333	1/4W 33K OHM	5RDAAD1180		
R16	RESISTOR FXD	RE15-YQ-18K OHM F	1/8W 18K OHM	5READ00474		
R17	RESISTOR FXD	ERD-25PJ273	1/4W 27K OHM	5RDAAD1259		
R18	RESISTOR FXD	ERD-25PJ133	1/4W 13K OHM	5RDAAD1177		
R19	RESISTOR FXD	RE15-YQ-7.5K OHM F	1/8W 7.5K OHM	5READ00573		
R20	RESISTOR FXD	ERD-25UJ103	1/4W 10K OHM	5RDAAD1369		
R21	RESISTOR FXD	RTL1/4C3-226K OHM F		5REAA05557		
R22	RESISTOR FXD	RTL1/4C3-226K OHM F		5REAA05557		
R23	RESISTOR FXD	RTL1/4C3-165 OHM F		5REAA05373		
R24	RESISTOR FXD	RE35-YQ-5.6K OHM F	1/4W 5.6K OHM	5READ00657		

9.10 CSA-222 Relay Circuit

PARTS LIST

RELAY CIRCUIT				TITLE	CSA-222	SHEET NO.
PART NO	PART NAME	TYPE	DESCRIPTION	1		
C1	CAP,FXD CER	ECKDAE222ZE		5CBAA00196		
C2	CAP,FXD CER	ECKDAE222ZE		5CBAA00196		
C3	CAP,FXD CER	ECKDAE222ZE		5CBAA00196		
C4	CAP,FXD CER	ECKDAE222ZE		5CBAA00196		
C5	CAP,FXD CER	DD106F103Z50	50V 10000PF	5CBAB00400		
C6	CAP,FXD CER	DD106F103Z50	50V 10000PF	5CBAB00400		
C7	CAP,FXD CER	DD106F103Z50	50V 10000PF	5CBAB00400		
CD1	SURGE ABSORBER	SNR-391KD20		5TZA00159		
CD2	SURGE ABSORBER	SNR-391KD20		5TZA00159		
CD3	SURGE ABSORBER	SNR-391KD20		5TZA00159		
J2	CONNECTOR	B2P-VH	2PIN	5JWAP00140		
J3	CONNECTOR	B4B-PH-K-S		5JWAP00250		
K1-1	RELAY	G2R-1A-E DC12V		5KLB00038		
K1-2	RELAY	G2R-1A-E DC12V		5KLB00038		
K2	RELAY	ST2-DC12V	8A AC250V	5KLAD00408		
L1	COIL	SF-T8-30S	30UH	5LCAC00248		
L2	COIL	SF-T8-30S	30UH	5LCAC00248		
PC1	PCB	H-6PCED01005B	CSA-222	6PCED01005		
S1	SWITCH	3T-206N		5SAAH00021		
T1	TRANSFORMER	H-6LRED00044		6LRED00044		
TB1	TERMINAL	PB-1-S		5JTCW00028		
TB2	TERMINAL	PB-1-S		5JTCW00028		
TB3	TERMINAL	P-424		5JJB00018		
TB4	TERMINAL	P-424		5JJB00018		
TB11	TERMINAL	PB-1-S		5JTCW00028		
TB12	TERMINAL	PB-1-S		5JTCW00028		
TB13	TERMINAL	PB-1-S		5JTCW00028		
TB14	TERMINAL	PB-1-S		5JTCW00028		

86

PARTS LIST

NOISE FILTER				TITLE	CFR-102	SHEET NO.
PART NO	PART NAME	TYPE	DESCRIPTION	1		
C701	CAP,FXD CER	RPE132F104Z50	0.1UF 50V	5CBAB01631		
C702	CAP,FXD CER	RPE132F104Z50	0.1UF 50V	5CBAB01631		
C703	CAP,FXD CER	RPE132F104Z50	0.1UF 50V	5CBAB01631		
C704	CAP,FXD CER	RPE132F104Z50	0.1UF 50V	5CBAB01631		
C705	CAP,FXD CER	RPE132F104Z50	0.1UF 50V	5CBAB01631		
C706	CAP,FXD CER	RPE132F104Z50	0.1UF 50V	5CBAB01631		
C707	CAP,FXD CER	RPE132F104Z50	0.1UF 50V	5CBAB01631		
C708	CAP,FXD CER	RPE132F104Z50	0.1UF 50V	5CBAB01631		
C709	CAP,FXD CER	RPE132F104Z50	0.1UF 50V	5CBAB01631		
C710	CAP,FXD CER	RPE132F104Z50	0.1UF 50V	5CBAB01631		
C711	CAP,FXD CER	RPE132F104Z50	0.1UF 50V	5CBAB01631		
C712	CAP,FXD CER	RPE132F104Z50	0.1UF 50V	5CBAB01631		
C713	CAP,FXD CER	RPE132F104Z50	0.1UF 50V	5CBAB01631		
J501	CONNECTOR	B15B-PH-K-S		5JWAP00262		
J503	CONNECTOR	HNC2-2.5P-2DS	2P	5JDA00276		
J504	CONNECTOR	B4B-PH-K-S		5JWAP00250		
L701	COIL	SF-T8-50S	72UH	5LCAC00148		
L702	COIL	SF-T8-50S	72UH	5LCAC00148		
L703	COIL	SF-T8-50S	72UH	5LCAC00148		
L704	COIL	SF-T8-50S	72UH	5LCAC00148		
L707	COIL	LF8S-101K	100UH	5LCAB00093		
L710	COIL	LF8S-101K	100UH	5LCAB00093		
L711	COIL	LF8S-101K	100UH	5LCAB00093		
L712	COIL	LAL04NA101K		5LCAA00202		
L713	COIL	LAL04NA101K		5LCAA00202		
L714	COIL	LAL04NA101K		5LCAA00202		
P1	TERMINAL	PB-1-S		5JTCW00028		
P2	TERMINAL	PB-1-S		5JTCW00028		
PC1	PCB	H-6PCED00985A		6PCED00985		
W701	CABLE	H-6ZCED11018		6ZCED11018		
W702	CABLE	H-6ZCED11019		6ZCED11019		

9.9 CFR-102 Noise Filter

35

PARTS LIST

PARTS LIST

MATCHING CKT					TITLE	SHEET NO.
					CFG-111	2
PART NO	PART	NAME	TYPE	DESCRIPTION	CODE	
C39	CAP,FXD	CER	RDA20-400PF	LEAD TYPE	5CCAG00029	
C40	CAP,FXD	CER	RDA20-400PF	LEAD TYPE	5CCAG00029	
C41	CAP,FXD	CER	RDA20 500PF		5CCAG00035	
C42	CAP,FXD	CER	RDA20 500PF		5CCAG00035	
C43	CAP,FXD	CER	RDA20 500PF		5CCAG00035	
C44	CAP,FXD	CER	RDA20 500PF		5CCAG00035	
C45	CAP,FXD	CER	RDA20-400PF	LEAD TYPE	5CCAG00029	
C101	CAP,FXD	CER	DD112B103K50	50V 10000PF	5CBAB00403	
C102	CAP,FXD	CER	DD112B103K50	50V 10000PF	5CBAB00403	
C103	CAP,FXD	CER	DD112B103K50	50V 10000PF	5CBAB00403	
C104	CAP,FXD	CER	DD112B103K50	50V 10000PF	5CBAB00403	
C105	CAP,FXD	CER	DD112B103K50	50V 10000PF	5CBAB00403	
C106	CAP,FXD	CER	DD112B103K50	50V 10000PF	5CBAB00403	
C107	CAP,FXD	CER	DD112B103K50	50V 10000PF	5CBAB00403	
C108	CAP,FXD	CER	DD112B103K50	50V 10000PF	5CBAB00403	
C109	CAP,FXD	CER	DD112B103K50	50V 10000PF	5CBAB00403	
C110	CAP,FXD	CER	DD112B103K50	50V 10000PF	5CBAB00403	
C111	CAP,FXD	CER	DD112B103K50	50V 10000PF	5CBAB00403	
C112	CAP,FXD	CER	DD112B103K50	50V 10000PF	5CBAB00403	
C113	CAP,FXD	CER	DD112B103K50	50V 10000PF	5CBAB00403	
C114	CAP,FXD	CER	DD112B103K50	50V 10000PF	5CBAB00403	
C115	CAP,FXD	CER	DD112B103K50	50V 10000PF	5CBAB00403	
C116	CAP,FXD	CER	DD112B103K50	50V 10000PF	5CBAB00403	
C117	CAP,FXD	CER	DD112B103K50	50V 10000PF	5CBAB00403	
C118	CAP,FXD	CER	DD112B103K50	50V 10000PF	5CBAB00403	
C119	CAP,FXD	CER	DD112B103K50	50V 10000PF	5CBAB00403	
C120	CAP,FXD	CER	DD112B103K50	50V 10000PF	5CBAB00403	
C121	CAP,FXD	CER	DD112B103K50	50V 10000PF	5CBAB00403	
C122	CAP,FXD	CER	DD112B103K50	50V 10000PF	5CBAB00403	
C123	CAP,FXD	CER	DD112B103K50	50V 10000PF	5CBAB00403	
C124	CAP,FXD	CER	DD112B103K50	50V 10000PF	5CBAB00403	
C125	CAP,FXD	CER	DD112B103K50	50V 10000PF	5CBAB00403	
C126	CAP,FXD	CER	DD112B103K50	50V 10000PF	5CBAB00403	
C127	CAP,FXD	CER	DD112B103K50	50V 10000PF	5CBAB00403	
C128	CAP,FXD	CER	DD112B103K50	50V 10000PF	5CBAB00403	

MATCHING CKT					TITLE	SHEET NO.
					CFG-111	1
PART NO	PART	NAME	TYPE	DESCRIPTION	CODE	
AR1	ARRESTER		DSA-701MA-06	700V	5ZABN00001	
C1	CAP,FXD	CER	SDA20 10PF		5CCAG00032	
C2	CAP,FXD	CER	RDA20-25PF		5CCAG00022	
C3	CAP,FXD	CER	RDA20-25PF		5CCAG00022	
C4	CAP,FXD	CER	RDA20-25PF		5CCAG00022	
C5	CAP,FXD	CER	RDA20-50PF	LEAD TYPE	5CCAG00023	
C6	CAP,FXD	CER	RDA20-50PF	LEAD TYPE	5CCAG00023	
C7	CAP,FXD	CER	RDA20-100PF		5CCAG00024	
C8	CAP,FXD	CER	RDA20-100PF		5CCAG00024	
C9	CAP,FXD	CER	RDA20-200PF		5CCAG00025	
C10	CAP,FXD	CER	RDA20-200PF		5CCAG00025	
C11	CAP,FXD	CER	RDA20-400PF	LEAD TYPE	5CCAG00029	
C12	CAP,FXD	CER	RDA20-400PF	LEAD TYPE	5CCAG00029	
C13	CAP,FXD	CER	RDA20-400PF	LEAD TYPE	5CCAG00029	
C14	CAP,FXD	CER	RDA20-400PF	LEAD TYPE	5CCAG00029	
C15	CAP,FXD	CER	RDA20-400PF	LEAD TYPE	5CCAG00029	
C16	CAP,FXD	CER	RDA20-400PF	LEAD TYPE	5CCAG00029	
C21	CAP,FXD	CER	SDA20 5PF		5CCAG00033	
C22	CAP,FXD	CER	SDA20 10PF		5CCAG00032	
C23	CAP,FXD	CER	SDA20 10PF		5CCAG00032	
C24	CAP,FXD	CER	SDA20 10PF		5CCAG00032	
C25	CAP,FXD	CER	RDA20 30PF		5CCAG00034	
C26	CAP,FXD	CER	SDA20 10PF		5CCAG00032	
C27	CAP,FXD	CER	RDA20-50PF	LEAD TYPE	5CCAG00023	
C28	CAP,FXD	CER	RDA20 30PF		5CCAG00034	
C29	CAP,FXD	CER	RDA20-50PF	LEAD TYPE	5CCAG00023	
C30	CAP,FXD	CER	RDA20-50PF	LEAD TYPE	5CCAG00023	
C31	CAP,FXD	CER	RDA20-50PF	LEAD TYPE	5CCAG00023	
C32	CAP,FXD	CER	RDA20-100PF		5CCAG00024	
C33	CAP,FXD	CER	RDA20-100PF		5CCAG00024	
C34	CAP,FXD	CER	RDA20-100PF		5CCAG00024	
C35	CAP,FXD	CER	RDA20-200PF		5CCAG00025	
C36	CAP,FXD	CER	RDA20-200PF		5CCAG00025	
C37	CAP,FXD	CER	RDA20-200PF		5CCAG00025	
C38	CAP,FXD	CER	RDA20-400PF	LEAD TYPE	5CCAG00029	

PARTS LIST

		MATCHING CKT			TITLE	SHEET NO.
		CFG-111				4
PART NO	PART	NAME	TYPE	DESCRIPTION	CODE	
C317	CAP,FXD	CER	DD112B103K50	50V 10000PF	5CBAB00403	
C318	CAP,FXD	CER	DD112B103K50	50V 10000PF	5CBAB00403	
C319	CAP,FXD	CER	DD112B103K50	50V 10000PF	5CBAB00403	
C320	CAP,FXD	CER	DD112B103K50	50V 10000PF	5CBAB00403	
C321	CAP,FXD	CER	DD112B103K50	50V 10000PF	5CBAB00403	
C322	CAP,FXD	CER	DD112B103K50	50V 10000PF	5CBAB00403	
C323	CAP,FXD	CER	DD112B103K50	50V 10000PF	5CBAB00403	
C324	CAP,FXD	CER	DD112B103K50	50V 10000PF	5CBAB00403	
C325	CAP,FXD	CER	DD112B103K50	50V 10000PF	5CBAB00403	
C326	CAP,FXD	CER	DD112B103K50	50V 10000PF	5CBAB00403	
C327	CAP,FXD	CER	DD112B103K50	50V 10000PF	5CBAB00403	
C328	CAP,FXD	CER	DD112B103K50	50V 10000PF	5CBAB00403	
C329	CAP,FXD	CER	DD112B103K50	50V 10000PF	5CBAB00403	
C330	CAP,FXD	CER	DD112B103K50	50V 10000PF	5CBAB00403	
C341	CAP,FXD	CER	DD112B103K50	50V 10000PF	5CBAB00403	
C342	CAP,FXD	CER	DD112B103K50	50V 10000PF	5CBAB00403	
C343	CAP,FXD	CER	DD112B103K50	50V 10000PF	5CBAB00403	
C344	CAP,FXD	CER	DD112B103K50	50V 10000PF	5CBAB00403	
C351	CAP,FXD	CER	DD112B103K50	50V 10000PF	5CBAB00403	
C352	CAP,FXD	CER	DD112B103K50	50V 10000PF	5CBAB00403	
C401	CAP,FXD	CER	CC45CH2H050DY	500V 5PF	5CAAB00962	
C402	CAP,FXD	CER	RPE131CH471K50	470P	5CAAA02860	
C404	CAP,FXD	CER	RPE131F104Z50	50V 0.1UF	5CBAB01611	
C405	CAP,FXD	CER	RPE131F104Z50	50V 0.1UF	5CBAB01611	
C406	CAP,FXD	CER	RPE131F104Z50	50V 0.1UF	5CBAB01611	
C407	CAP,FXD	CER	RPE131F104Z50	50V 0.1UF	5CBAB01611	
C408	CAP,FXD	CER	RPE131CH331K50	330P	5CAAA02838	
C409	CAP,FXD	CER	RPE131CH331K50	330P	5CAAA02838	
C410	CAP,FXD	CER	RPE131F104Z50	50V 0.1UF	5CBAB01611	
C411	CAP,FXD	CER	RPE131F104Z50	50V 0.1UF	5CBAB01611	
C412	CAP,FXD	CER	RPE131F104Z50	50V 0.1UF	5CBAB01611	
C413	CAP,FXD	CER	RPE131F104Z50	50V 0.1UF	5CBAB01611	
C414	CAP,FXD	CER	RPE131F104Z50	50V 0.1UF	5CBAB01611	
C421	CAP,FXD	CER	CC45CH2H050DY	500V 5PF	5CAAB00962	
C422	CAP,FXD	CER	RPE131CH471K50	470P	5CAAA02860	

PARTS LIST

		MATCHING CKT			TITLE	SHEET NO.
		CFG-111				3
PART NO	PART	NAME	TYPE	DESCRIPTION	CODE	
C129	CAP,FXD	CER	DD112B103K50	50V 10000PF	5CBAB00403	
C130	CAP,FXD	CER	DD112B103K50	50V 10000PF	5CBAB00403	
C151	CAP,FXD	MICA	DM19C332J3	300WV 3300PF	5CMAB00124	
C152	CAP,FXD	MICA	DM19C332J3	300WV 3300PF	5CMAB00124	
C153	CAP,FXD	MICA	DM19C332J3	300WV 3300PF	5CMAB00124	
C154	CAP,FXD	MICA	DM19C332J3	300WV 3300PF	5CMAB00124	
C155	CAP,FXD	MICA	DM19C332J3	300WV 3300PF	5CMAB00124	
C156	CAP,FXD	MICA	DM19C332J3	300WV 3300PF	5CMAB00124	
C157	CAP,FXD	MICA	DM19C332J3	300WV 3300PF	5CMAB00124	
C201	CAP,FXD	CER	CC45CH2H050DY	500V 5PF	5CAAB00962	
C202	CAP,FXD	CER	CC45CH2H050DY	500V 5PF	5CAAB00962	
C205	CAP,FXD	CER	RPE131CH331K50	330P	5CAAA02838	
C206	CAP,FXD	CER	RPE131CH331K50	330P	5CAAA02838	
C207	CAP,FXD	CER	RPE131CH102K50	50V 1000PF	5CAAA02631	
C208	CAP,FXD	CER	RPE131CH102K50	50V 1000PF	5CAAA02631	
C209	CAP,FXD	CER	RPE131CH102K50	50V 1000PF	5CAAA02631	
C210	CAP,FXD	CER	RPE131CH102K50	50V 1000PF	5CAAA02631	
C211	CAP,FXD	CER	DD106CH470J50	50V 47PF	5CAAA00854	
C212	CAP,FXD	CER	DD106CH470J50	50V 47PF	5CAAA00854	
C301	CAP,FXD	CER	DD112B103K50	50V 10000PF	5CBAB00403	
C302	CAP,FXD	CER	DD112B103K50	50V 10000PF	5CBAB00403	
C303	CAP,FXD	CER	DD112B103K50	50V 10000PF	5CBAB00403	
C304	CAP,FXD	CER	DD112B103K50	50V 10000PF	5CBAB00403	
C305	CAP,FXD	CER	DD112B103K50	50V 10000PF	5CBAB00403	
C306	CAP,FXD	CER	DD112B103K50	50V 10000PF	5CBAB00403	
C307	CAP,FXD	CER	DD112B103K50	50V 10000PF	5CBAB00403	
C308	CAP,FXD	CER	DD112B103K50	50V 10000PF	5CBAB00403	
C309	CAP,FXD	CER	DD112B103K50	50V 10000PF	5CBAB00403	
C310	CAP,FXD	CER	DD112B103K50	50V 10000PF	5CBAB00403	
C311	CAP,FXD	CER	DD112B103K50	50V 10000PF	5CBAB00403	
C312	CAP,FXD	CER	DD112B103K50	50V 10000PF	5CBAB00403	
C313	CAP,FXD	CER	DD112B103K50	50V 10000PF	5CBAB00403	
C314	CAP,FXD	CER	DD112B103K50	50V 10000PF	5CBAB00403	
C315	CAP,FXD	CER	DD112B103K50	50V 10000PF	5CBAB00403	
C316	CAP,FXD	CER	DD112B103K50	50V 10000PF	5CBAB00403	

68

PARTS LIST

PARTS LIST					SHEET NO.
MATCHING CKT				TITLE	6
				CFG-111	
PART NO	PART NAME	TYPE	DESCRIPTION	CODE	
K7	RELAY	G2R-1A-E	DC12V	5KLB00038	
K8	RELAY	G2R-1A-E	DC12V	5KLB00038	
K9	RELAY	G2R-1A-E	DC12V	5KLB00038	
K10	RELAY	G2R-1A-E	DC12V	5KLB00038	
K11	RELAY	G2R-1A-E	DC12V	5KLB00038	
K12	RELAY	G2R-1A-E	DC12V	5KLB00038	
K13	RELAY	G2R-1A-E	DC12V	5KLB00038	
K14	RELAY	G2R-1A-E	DC12V	5KLB00038	
K15	RELAY	G2R-1A-E	DC12V	5KLB00038	
K16	RELAY	G2R-1A-E	DC12V	5KLB00038	
K17	RELAY	G2R-1A-E	DC12V	5KLB00038	
K18	RELAY	G2R-1A-E	DC12V	5KLB00038	
K19	RELAY	G2R-1A-E	DC12V	5KLB00038	
K20	RELAY	G2R-1A-E	DC12V	5KLB00038	
K21	RELAY	G2R-1A-E	DC12V	5KLB00038	
K22	RELAY	G2R-1A-E	DC12V	5KLB00038	
K23	RELAY	G2R-1A-E	DC12V	5KLB00038	
K24	RELAY	G2R-1A-E	DC12V	5KLB00038	
K25	RELAY	G2R-1A-E	DC12V	5KLB00038	
K26	RELAY	G2R-1A-E	DC12V	5KLB00038	
K27	RELAY	G2R-1A-E	DC12V	5KLB00038	
K28	RELAY	G2R-1A-E	DC12V	5KLB00038	
K29	RELAY	G2R-1A-E	DC12V	5KLB00038	
K30	RELAY	G2R-1A-E	DC12V	5KLB00038	
L1	COIL	H-6LFED00038	0.3UH	6LFED00038	
L2	COIL	H-6LFKD00158	0.4UH	6LFKD00158	
L3	COIL	H-6LFED00040	0.6UH	6LFED00040	
L4	COIL	H-6LFED00043	1.6UH	6LFED00043	
L5	COIL	H-6LFED00043	1.6UH	6LFED00043	
L6	COIL	H-6LFED00045	3.2UH	6LFED00045	
L7	COIL	H-6LFED00044	1.6UH	6LFED00044	
L8	COIL	H-6LFKD00159	0.8UH	6LFKD00159	
L9	COIL	H-6LFED00041	1.0UH	6LFED00041	
L10	COIL	H-6LFKD00158	0.4UH	6LFKD00158	
L11	COIL	H-6LFKD00157	0.2UH	6LFKD00157	

PARTS LIST

PARTS LIST					SHEET NO.
MATCHING CKT				TITLE	5
				CFG-111	
PART NO	PART NAME	TYPE	DESCRIPTION	CODE	
C424	CAP,FXD	CER	RPE131F104Z50	50V 0.1UF	5CBAB01611
C441	CAP,FXD	CER	CC45CH2H050DY	500V 5PF	5CAA00962
C442	CAP,FXD	CER	RPE131CH471K50	470P	5CAA02860
C444	CAP,FXD	CER	RPE131F104Z50	50V 0.1UF	5CBAB01611
C445	CAP,FXD	CER	RPE131F104Z50	50V 0.1UF	5CBAB01611
C461	CAP,FXD	CER	RPE131F104Z50	50V 0.1UF	5CBAB01611
C462	CAP,FXD	CER	RPE131F104Z50	50V 0.1UF	5CBAB01611
C463	CAP,FXD	CER	RPE131F104Z50	50V 0.1UF	5CBAB01611
C464	CAP,FXD	CER	RPE131F104Z50	50V 0.1UF	5CBAB01611
C465	CAP,FXD	CER	RPE131F104Z50	50V 0.1UF	5CBAB01611
CD201	DIODE		1N60		5TXAF00026
CD202	DIODE		1N60		5TXAF00026
CD301	DIODE		DAN801		5TXCW00017
CD302	DIODE		DAN801		5TXCW00017
CD303	DIODE		DAN801		5TXCW00017
CD304	DIODE		DAN801		5TXCW00017
CD401	DIODE		1N60		5TXAF00026
CD402	DIODE		1N60		5TXAF00026
CD421	DIODE		1N60		5TXAF00026
CD441	DIODE		1N60		5TXAF00026
IC301	IC		M54975P		5DAAB00200
IC302	IC		M54975P		5DAAB00200
IC303	IC		M54975P		5DAAB00200
IC304	IC		M54975P		5DAAB00200
IC401	IC		MC10115L		5DAAJ00120
IC402	IC		HD10231		5DDAF00345
IC403	IC		NJM2902N		5DAAN00004
IC404	IC		NJM2902N		5DAAN00004
IC405	IC		NJM2902N		5DAAN00004
K1	RELAY	G2R-1A-E	DC12V	5KLB00038	
K2	RELAY	G2R-1A-E	DC12V	5KLB00038	
K3	RELAY	G2R-1A-E	DC12V	5KLB00038	
K4	RELAY	G2R-1A-E	DC12V	5KLB00038	
K5	RELAY	G2R-1A-E	DC12V	5KLB00038	
K6	RELAY	G2R-1A-E	DC12V	5KLB00038	

PARTS LIST

		TITLE		SHEET NO.	
		MATCHING CKT		CFG-111	
				8	
PART NO	PART NAME	TYPE	DESCRIPTION	CODE	
L328	COIL	FL-5H101K	100UH	5LCAA00013	
L329	COIL	FL-5H101K	100UH	5LCAA00013	
L330	COIL	FL-5H101K	100UH	5LCAA00013	
L401	COIL	FL-5H331K	330UH	5LCAA00016	
L402	COIL	FL-5H331K	330UH	5LCAA00016	
L403	COIL	FL-5H331K	330UH	5LCAA00016	
L404	COIL	FL-5H331K	330UH	5LCAA00016	
L405	COIL	FL-5H331K	330UH	5LCAA00016	
L421	COIL	FL-5H331K	330UH	5LCAA00016	
L441	COIL	FL-5H331K	330UH	5LCAA00016	
PC1	PCB	H-6PCED00854F	CFG-111	6PCED00854	
R201	RESISTOR FXD	ERG-12SJ330		5REAG03483	
R202	RESISTOR FXD	ERG-12SJ330		5REAG03483	
R203	RESISTOR FXD	ERG-12SJ330		5REAG03483	
R204	RESISTOR FXD	ERG-12SJ330		5REAG03483	
R205	RESISTOR FXD	ERG-12SJ330		5REAG03483	
R206	RESISTOR FXD	ERG-12SJ330		5REAG03483	
R301	RESISTOR FXD	ERD-25UJ103	1/4W 10K OHM	5RDAA01369	
R302	RESISTOR FXD	ERD-25UJ103	1/4W 10K OHM	5RDAA01369	
R303	RESISTOR FXD	ERD-25UJ103	1/4W 10K OHM	5RDAA01369	
R304	RESISTOR FXD	ERD-25UJ103	1/4W 10K OHM	5RDAA01369	
R401	RESISTOR FXD	ERD-25UJ222	1/4W 2.2K OHM	5RDAA01353	
R402	RESISTOR FXD	ERD-25UJ104	1/4W 100K OHM	5RDAA01393	
R403	RESISTOR FXD	ERD-25UJ222	1/4W 2.2K OHM	5RDAA01353	
R404	RESISTOR FXD	ERD-25UJ104	1/4W 100K OHM	5RDAA01393	
R405	RESISTOR FXD	ERD-25UJ103	1/4W 10K OHM	5RDAA01369	
R406	RESISTOR FXD	ERD-25UJ104	1/4W 100K OHM	5RDAA01393	
R407	RESISTOR FXD	RE35-YQ-330 OHM F	1/4W 330 OHM	5READ00286	
R408	RESISTOR FXD	RE35-YQ-330 OHM F	1/4W 330 OHM	5READ00286	
R409	RESISTOR FXD	RE35-YQ-330 OHM F	1/4W 330 OHM	5READ00286	
R410	RESISTOR FXD	RE35-YQ-330 OHM F	1/4W 330 OHM	5READ00286	
R411	RESISTOR FXD	ERD-25UJ681	1/4W 680 OHM	5RDAA01341	
R412	RESISTOR FXD	ERD-25UJ681	1/4W 680 OHM	5RDAA01341	
R413	RESISTOR FXD	ERD-25UJ103	1/4W 10K OHM	5RDAA01369	
R414	RESISTOR FXD	ERD-25UJ104	1/4W 100K OHM	5RDAA01393	

PARTS LIST

		TITLE		SHEET NO.	
		MATCHING CKT		CFG-111	
				7	
PART NO	PART NAME	TYPE	DESCRIPTION	CODE	
L12	COIL	H-6LFKD00156		6LFKD00156	
L13	COIL	H-6LFED00038	0.3UH	6LFED00038	
L151	COIL	SF-T8-50S	72UH	5LCAC00148	
L152	COIL	SF-T8-50S	72UH	5LCAC00148	
L201	COIL	LAL03KH331K	330UH	5LCAA00250	
L202	COIL	LAL03KH331K	330UH	5LCAA00250	
L203	COIL	LAL03KH331K	330UH	5LCAA00250	
L204	COIL	LAL03KH331K	330UH	5LCAA00250	
L301	COIL	FL-5H101K	100UH	5LCAA00013	
L302	COIL	FL-5H101K	100UH	5LCAA00013	
L303	COIL	FL-5H101K	100UH	5LCAA00013	
L304	COIL	FL-5H101K	100UH	5LCAA00013	
L305	COIL	FL-5H101K	100UH	5LCAA00013	
L306	COIL	FL-5H101K	100UH	5LCAA00013	
L307	COIL	FL-5H101K	100UH	5LCAA00013	
L308	COIL	FL-5H101K	100UH	5LCAA00013	
L309	COIL	FL-5H101K	100UH	5LCAA00013	
L310	COIL	FL-5H101K	100UH	5LCAA00013	
L311	COIL	FL-5H101K	100UH	5LCAA00013	
L312	COIL	FL-5H101K	100UH	5LCAA00013	
L313	COIL	FL-5H101K	100UH	5LCAA00013	
L314	COIL	FL-5H101K	100UH	5LCAA00013	
L315	COIL	FL-5H101K	100UH	5LCAA00013	
L316	COIL	FL-5H101K	100UH	5LCAA00013	
L317	COIL	FL-5H101K	100UH	5LCAA00013	
L318	COIL	FL-5H101K	100UH	5LCAA00013	
L319	COIL	FL-5H101K	100UH	5LCAA00013	
L320	COIL	FL-5H101K	100UH	5LCAA00013	
L321	COIL	FL-5H101K	100UH	5LCAA00013	
L322	COIL	FL-5H101K	100UH	5LCAA00013	
L323	COIL	FL-5H101K	100UH	5LCAA00013	
L324	COIL	FL-5H101K	100UH	5LCAA00013	
L325	COIL	FL-5H101K	100UH	5LCAA00013	
L326	COIL	FL-5H101K	100UH	5LCAA00013	
L327	COIL	FL-5H101K	100UH	5LCAA00013	

06

35

PARTS LIST

PARTS LIST					TITLE	SHEET NO.
					ANTENNA SWITCH	CSC-433
PART NO	PART NAME	TYPE	DESCRIPTION	CODE		
AR1	ARRESTER	DSA-701MA-06	700V	5ZABN00001		
C1	CAP,FXD CER	DD112B103K50	50V 10000PF	5CBAB00403		
C2	CAP,FXD CER	DD112B103K50	50V 10000PF	5CBAB00403		
C3	CAP,FXD CER	DD112B103K50	50V 10000PF	5CBAB00403		
C4	CAP,FXD CER	DD112B103K50	50V 10000PF	5CBAB00403		
C5	CAP,FXD CER	DD112B103K50	50V 10000PF	5CBAB00403		
C6	CAP,FXD CER	DD112B103K50	50V 10000PF	5CBAB00403		
C7	CAP,FXD CER	DD112B103K50	50V 10000PF	5CBAB00403		
C8	CAP,FXD CER	DD112B103K50	50V 10000PF	5CBAB00403		
C9	CAP,FXD CER	DD112B103K50	50V 10000PF	5CBAB00403		
C10	CAP,FXD CER	DD112B103K50	50V 10000PF	5CBAB00403		
C11	CAP,FXD CER	DD112B103K50	50V 10000PF	5CBAB00403		
C12	CAP,FXD CER	DD112B103K50	50V 10000PF	5CBAB00403		
C13	CAP,FXD CER	DD112B103K50	50V 10000PF	5CBAB00403		
C14	CAP,FXD CER	DD112B103K50	50V 10000PF	5CBAB00403		
C15	CAP,FXD CER	DD112B103K50	50V 10000PF	5CBAB00403		
C16	CAP,FXD CER	DD112B103K50	50V 10000PF	5CBAB00403		
C17	CAP,FXD CER	DD112B103K50	50V 10000PF	5CBAB00403		
C18	CAP,FXD CER	DD112B103K50	50V 10000PF	5CBAB00403		
C19	CAP,FXD CER	DD112B103K50	50V 10000PF	5CBAB00403		
C20	CAP,FXD CER	DD112B103K50	50V 10000PF	5CBAB00403		
C21	CAP,FXD CER	DD112B103K50	50V 10000PF	5CBAB00403		
C22	CAP,FXD CER	DD112B103K50	50V 10000PF	5CBAB00403		
C23	CAP,FXD CER	DD112B103K50	50V 10000PF	5CBAB00403		
C24	CAP,FXD CER	DD112B103K50	50V 10000PF	5CBAB00403		
C25	CAP,FXD CER	DD112B103K50	50V 10000PF	5CBAB00403		
C26	CAP,FXD CER	DD112B103K50	50V 10000PF	5CBAB00403		
C27	CAP,FXD CER	DD112B103K50	50V 10000PF	5CBAB00403		
J1	CONNECTOR	FM-203		5JJB000003		
J2-1	CONNECTOR	FM-203		5JJB000003		
J2-2	CONNECTOR	FM-203		5JJB000003		
J2-3	CONNECTOR	FM-203		5JJB000003		
J2-4	CONNECTOR	FM-203		5JJB000003		
J301	PIN JACK	TMP-J01X-V6		5JWCL00058		
J302	PIN JACK	TMP-J01X-V6		5JWCL00058		

9.12 CSC-433 Antenna Switch

PARTS LIST

PARTS LIST					TITLE	SHEET NO.
					MATCHING CKT	CFG-111
PART NO	PART NAME	TYPE	DESCRIPTION	CODE		
R420	RESISTOR FXD	ERG-12SJ220		5REAG03484		
R421	RESISTOR FXD	ERG-12SJ220		5REAG03484		
R422	RESISTOR FXD	RE35-YQ-39 OHM F		5READ00352		
R431	RESISTOR FXD	RE35-YQ-33K OHM F	1/4W 33K OHM	5READ00154		
R432	RESISTOR FXD	RE35-YQ-6.8K OHM F	1/4W 6.8K OHM	5READ00304		
R433	RESISTOR FXD	RE35-YQ-7.5K OHM F	1/4W 7.5K OHM	5READ00440		
R434	RESISTOR FXD	RE35-YQ-2.4K OHM F		5READ00350		
R435	RESISTOR FXD	ERD-25UJ105	1/4W 1M OHM	5RDA01417		
R436	RESISTOR FXD	ERD-25UJ103	1/4W 10K OHM	5RDA01369		
R437	RESISTOR FXD	ERD-25UJ103	1/4W 10K OHM	5RDA01369		
R440	RESISTOR FXD	ERG-12SJ220		5REAG03484		
R441	RESISTOR FXD	ERG-12SJ220		5REAG03484		
R442	RESISTOR FXD	RE35-YQ-39 OHM F		5READ00352		
R449	RESISTOR FXD	ERD-25UJ473	1/4W 47K OHM	5RDA01385		
R451	RESISTOR FXD	ERD-25UJ103	1/4W 10K OHM	5RDA01369		
R452	RESISTOR FXD	ERD-25UJ103	1/4W 10K OHM	5RDA01369		
R453	RESISTOR FXD	ERD-25UJ103	1/4W 10K OHM	5RDA01369		
R454	RESISTOR FXD	ERD-25UJ104	1/4W 100K OHM	5RDA01393		
R455	RESISTOR FXD	ERD-25UJ104	1/4W 100K OHM	5RDA01393		
R456	RESISTOR FXD	ERD-25UJ104	1/4W 100K OHM	5RDA01393		
T1	RF XFMR	H-6LHED00364A		6LHED00364		
T2	RF XFMR	H-6LHED00364A		6LHED00364		
TB1	TERMINAL	PB-1-S		5JTCW00028		
TB2	TERMINAL	PB-1-S		5JTCW00028		
TB3	TERMINAL	PB-1-S		5JTCW00028		
TB4	TERMINAL	PB-1-S		5JTCW00028		
TP1	TERMINAL	CP-8		5JTBV00005		
TP2	TERMINAL	CP-8		5JTBV00005		
W1	COAXIAL CABLE	DFS040		2663111115		
W404	CABLE	H-6ZCED11003	9P 100	6ZCED11003		
W405	CABLE	H-6ZCED11004	14P 100	6ZCED11004		

PARTS LIST

		TITLE		SHEET NO.
CONTROL		CDJ-1143		1
PART NO	PART NAME	TYPE	DESCRIPTION	CODE
C6	CAP,FXD ELCTLT	ECC5R5V224		5CEAA02926
C100	CAP,FXD ELCTLT	ECEA1EU100	25V 10UF	5CEAA01845
C101	CAP,FXD ELCTLT	ECE-A1EU101	25V 100UF	5CEAA01839
C102	CAP,FXD ELCTLT	ECE-A1EU101	25V 100UF	5CEAA01839
C103	CAP,FXD ELCTLT	ECE-A1EU101	25V 100UF	5CEAA01839
CD1	PHOTO COUPLER	TLP521-4-GB		5TZAD00213
CD8	DIODE	1N60		5TXET00001
CD20	LED	TLR102A		5TZAD00020
CD21	LED	TLR102A		5TZAD00020
CD22	LED	TLR102A		5TZAD00020
CD24	LED	TLR102A		5TZAD00020
CD25	LED	TLR102A		5TZAD00020
CD31	DIODE	HZ16-2		5TXAE00231
IC1	IC	UPD78C10ACW		5DDAC00794
IC9	IC	TC4555BP		5DDAE00117
IC12	IC	S-8054ALR		5DZBX00003
IC13	IC	NJM78L05A	5V 0.1A	5DAAN00046
ICS1	IC SOCKET	ICC05-028-360GP		5ZJCK00061
J3	CONNECTOR	XM3B-1532-112		5JJJC00042
J401	CONNECTOR	B15B-PH-K-S		5JWAP00262
J403	CONNECTOR	S16B-PH-K-S	16P	5JWAP00378
J404	CONNECTOR	B9B-PH-K-S		5JWAP00252
J405	CONNECTOR	B14B-PH-K-S	14P	5JWAP00337
J406	CONNECTOR	B8B-PH-K-S		5JWAP00389
J407	CONNECTOR	S4B-PH-K-S	4P	5JWAP00406
J408	CONNECTOR	B13B-PH-K-S	13P	5JWAP00400
J409	CONNECTOR	B14B-PH-K-S	14P	5JWAP00337
J410	CONNECTOR	TMP-J01X-A2		5JWCL00045
R5	RESISTOR	MHR-8-103JA	10K OHM X8	5RZAB00709
R6	RESISTOR	MHR-8-103JA	10K OHM X8	5RZAB00709
R17	RESISTOR	EXB-F8V101J		5RZAS00439
R30	RESISTOR FXD	RKLB4-103J		5REAE00160
R31	RESISTOR FXD	EXB-F5E102J		5RZAS00429
R151	RESISTOR FXD	ERD-25UJ2R2	1/4W 2.2 OHM	5RDAAO1287
R152	RESISTOR FXD	ERD-25UJ2R2	1/4W 2.2 OHM	5RDAAO1287

9.13 CDJ-1143 Control

PARTS LIST

		TITLE		SHEET NO.
ANTENNA SWITCH		CSC-433		2
PART NO	PART NAME	TYPE	DESCRIPTION	CODE
J303	PIN JACK	TMP-J01X-V6		5JWCL00058
K1	RELAY	G6G-234C-12V		5KLAF00602
K2	RELAY	G6G-234C-12V		5KLAF00602
K3-1	RELAY	DSP1-DC12V		5KLAD00664
K3-2	RELAY	DSP2A-DC12V		5KLAD00833
K4	RELAY	G2R-1A-E-AP DC-12V		5KLAF00663
K5	RELAY	G2R-1A-E-AP DC-12V		5KLAF00663
K6	RELAY	G2R-1A-E-AP DC-12V		5KLAF00663
K7	RELAY	G2R-1A-E-AP DC-12V		5KLAF00663
K8	RELAY	G6E-134P-USDC12V		5KLBM00017
L1	COIL	LAL04NA101K		5LCAA00202
L2	COIL	LAL04NA101K		5LCAA00202
L3	COIL	LAL04NA101K		5LCAA00202
L4	COIL	LAL04NA101K		5LCAA00202
L5	COIL	LAL04NA101K		5LCAA00202
L6	COIL	LAL04NA101K		5LCAA00202
L7	COIL	LAL04NA101K		5LCAA00202
L8	COIL	LAL04NA101K		5LCAA00202
L9	COIL	LAL04NA101K		5LCAA00202
PC1	PCB	H-6PCED00913C	CSC-433	6PCED00913
R1	RESISTOR FXD	ERG-2SJ472	2W 47K OHM	5REAG03209
R2	RESISTOR FXD	ERG-2SJ472	2W 47K OHM	5REAG03209
W1	COAXIAL CABLE	5D-2V		2661111161
W301	CABLE	H-6ZCED14600A	1.5D 60CM	6ZCED14600
W302	CABLE	H-6ZCED14400A	1.5D 2V	6ZCED14400
W303	CABLE	H-6ZCED14300A	1.5D 2V	6ZCED14300
W406	CABLE	H-6ZCED11017	8P,200	6ZCED11017

PARTS LIST

		TITLE		SHEET NO.	
		CONTROL		CDJ-1143-CHIP	
				1	
PART NO	PART NAME	TYPE	DESCRIPTION	CODE	
C1	CAP,FXD C CER	C3216JF1H104Z-E-TP	50V 0.1UF	5CAAD01268	
C2	CAP,FXD CER	C3216CH1H100D-E-TP	10PF	5CAAD00785	
C3	CAP,FXD CER	C3216CH1H100D-E-TP	10PF	5CAAD00785	
C4	CAP,FXD C CER	C3216JF1H104Z-E-TP	50V 0.1UF	5CAAD01268	
C5	CAP,FXD C CER	C3216JF1H104Z-E-TP	50V 0.1UF	5CAAD01268	
C10	CAP,FXD CER	C3216JB1H102K-E-TP	1000PF 50V	5CAAD01267	
C11	CAP,FXD C CER	C3216JB1H103K-E-TP	50V 0.01UF	5CAAD00789	
C12	CAP,FXD C CER	C3216JB1H103K-E-TP	50V 0.01UF	5CAAD00789	
C13	CAP,FXD CER	C3216JB1H102K-E-TP	1000PF 50V	5CAAD01267	
C14	CAP,FXD CER	C3216JB1H102K-E-TP	1000PF 50V	5CAAD01267	
C15	CAP,FXD C CER	C3216JB1H103K-E-TP	50V 0.01UF	5CAAD00789	
C16	CAP,FXD C CER	C3216JB1H103K-E-TP	50V 0.01UF	5CAAD00789	
C17	CAP,FXD C CER	C3216JB1H103K-E-TP	50V 0.01UF	5CAAD00789	
C18	CAP,FXD C CER	C3216JB1H103K-E-TP	50V 0.01UF	5CAAD00789	
C19	CAP,FXD C CER	C3216JB1H103K-E-TP	50V 0.01UF	5CAAD00789	
C20	CAP,FXD C CER	C3216JB1H103K-E-TP	50V 0.01UF	5CAAD00789	
C21	CAP,FXD C CER	C3216JB1H103K-E-TP	50V 0.01UF	5CAAD00789	
C22	CAP,FXD C CER	C3216JB1H103K-E-TP	50V 0.01UF	5CAAD00789	
C23	CAP,FXD C CER	C3216JB1H103K-E-TP	50V 0.01UF	5CAAD00789	
C24	CAP,FXD C CER	C3216JB1H103K-E-TP	50V 0.01UF	5CAAD00789	
C25	CAP,FXD C CER	C3216JB1H103K-E-TP	50V 0.01UF	5CAAD00789	
C26	CAP,FXD CER	C3216JB1H102K-E-TP	1000PF 50V	5CAAD01267	
C27	CAP,FXD CER	C3216JB1H102K-E-TP	1000PF 50V	5CAAD01267	
C30	CAP,FXD C CER	C3216JB1H103K-E-TP	50V 0.01UF	5CAAD00789	
C31	CAP,FXD C CER	C3216JB1H103K-E-TP	50V 0.01UF	5CAAD00789	
C32	CAP,FXD C CER	C3216JB1H103K-E-TP	50V 0.01UF	5CAAD00789	
C34	CAP,FXD C CER	C3216JB1H103K-E-TP	50V 0.01UF	5CAAD00789	
C35	CAP,FXD C CER	C3216JB1H103K-E-TP	50V 0.01UF	5CAAD00789	
C36	CAP,FXD CER	C3216JB1H102K-E-TP	1000PF 50V	5CAAD01267	
C37	CAP,FXD CER	C3216JB1H102K-E-TP	1000PF 50V	5CAAD01267	
C38	CAP,FXD CER	C3216JB1H102K-E-TP	1000PF 50V	5CAAD01267	
C39	CAP,FXD CER	C3216JB1H102K-E-TP	1000PF 50V	5CAAD01267	
C40	CAP,FXD CER	C3216JB1H102K-E-TP	1000PF 50V	5CAAD01267	
C41	CAP,FXD C CER	C3216JB1H103K-E-TP	50V 0.01UF	5CAAD00789	
C42	CAP,FXD C CER	C3216JB1H103K-E-TP	50V 0.01UF	5CAAD00789	

PARTS LIST

		TITLE		SHEET NO.	
		CONTROL		CDJ-1143	
				2	
PART NO	PART NAME	TYPE	DESCRIPTION	CODE	
R153	RESISTOR FXD	ERD-25UJ2R2	1/4W 2.2 OHM	5RDAA01287	
R154	RESISTOR FXD	ERD-25UJ2R2	1/4W 2.2 OHM	5RDAA01287	
ROM1	IC	H-7DDED0510	CDJ-1143	7DDED0510	
RV2	RESISTOR VAR	EVN-D2AA03B14		5RVAB00430	
S1	SWITCH	BS4-01		5SZJR00002	
S2	SWITCH	B3F-1022		5SCAP00026	
TR2	TRANSISTOR	2SC1906		5TCAA00129	
TR3	TRANSISTOR	2SA1015-Y		5TAAG00070	
TR4	TRANSISTOR	2SK941	100V 0.6A	5TKAA00230	
TR6	TRANSISTOR	2SC2655-Y		5TCAF00246	
X1	CRYSTAL	NR-18 LN-X-0008 F=7.3728MHZ		5XHAA00966	

96

15

20

25

30

35

PARTS LIST

CONTROL					TITLE	SHEET NO.
CONTROL					CDJ-1143-CHIP	3
PART NO	PART NAME	TYPE	DESCRIPTION	CODE		
C120	CAP,FXD C CER	C3216JB1H103K-E-TP	50V 0.01UF	SCAAD00789		
C121	CAP,FXD C CER	C3216JB1H103K-E-TP	50V 0.01UF	SCAAD00789		
C122	CAP,FXD C CER	C3216JB1H103K-E-TP	50V 0.01UF	SCAAD00789		
C123	CAP,FXD C CER	C3216JB1H103K-E-TP	50V 0.01UF	SCAAD00789		
C124	CAP,FXD C CER	C3216JB1H103K-E-TP	50V 0.01UF	SCAAD00789		
C125	CAP,FXD C CER	C3216JB1H103K-E-TP	50V 0.01UF	SCAAD00789		
C126	CAP,FXD C CER	C3216JB1H103K-E-TP	50V 0.01UF	SCAAD00789		
C127	CAP,FXD C CER	C3216JB1H103K-E-TP	50V 0.01UF	SCAAD00789		
C128	CAP,FXD C CER	C3216JB1H103K-E-TP	50V 0.01UF	SCAAD00789		
C129	CAP,FXD C CER	C3216JB1H103K-E-TP	50V 0.01UF	SCAAD00789		
C141	CAP,FXD C CER	C3216JB1H103K-E-TP	50V 0.01UF	SCAAD00789		
C151	CAP,FXD C CER	C3216JB1H103K-E-TP	50V 0.01UF	SCAAD00789		
C152	CAP,FXD C CER	C3216JB1H103K-E-TP	50V 0.01UF	SCAAD00789		
C153	CAP,FXD C CER	C3216JB1H103K-E-TP	50V 0.01UF	SCAAD00789		
C154	CAP,FXD CER	C3216JB1H102K-E-TP	1000PF 50V	SCAAD01267		
C155	CAP,FXD CER	C3216JB1H102K-E-TP	1000PF 50V	SCAAD01267		
C160	CAP,FXD C CER	C3216JB1H103K-E-TP	50V 0.01UF	SCAAD00789		
C161	CAP,FXD C CER	C3216JB1H103K-E-TP	50V 0.01UF	SCAAD00789		
C162	CAP,FXD C CER	C3216JB1H103K-E-TP	50V 0.01UF	SCAAD00789		
C163	CAP,FXD C CER	C3216JB1H103K-E-TP	50V 0.01UF	SCAAD00789		
C164	CAP,FXD C CER	C3216JB1H103K-E-TP	50V 0.01UF	SCAAD00789		
C165	CAP,FXD C CER	C3216JB1H103K-E-TP	50V 0.01UF	SCAAD00789		
C166	CAP,FXD C CER	C3216JB1H103K-E-TP	50V 0.01UF	SCAAD00789		
C167	CAP,FXD C CER	C3216JB1H103K-E-TP	50V 0.01UF	SCAAD00789		
C168	CAP,FXD C CER	C3216JB1H103K-E-TP	50V 0.01UF	SCAAD00789		
C169	CAP,FXD C CER	C3216JB1H103K-E-TP	50V 0.01UF	SCAAD00789		
C170	CAP,FXD C CER	C3216JB1H103K-E-TP	50V 0.01UF	SCAAD00789		
C171	CAP,FXD C CER	C3216JB1H103K-E-TP	50V 0.01UF	SCAAD00789		
C172	CAP,FXD C CER	C3216JB1H103K-E-TP	50V 0.01UF	SCAAD00789		
C173	CAP,FXD C CER	C3216JB1H103K-E-TP	50V 0.01UF	SCAAD00789		
CD2	DIODE	1SS187 TE85L		5TXAD00397		
CD3	DIODE	1SS187 TE85L		5TXAD00397		
CD4	DIODE	1SS187 TE85L		5TXAD00397		
CD5	DIODE	1SS187 TE85L		5TXAD00397		
CD6	DIODE	1SS187 TE85L		5TXAD00397		

94

PARTS LIST

CONTROL					TITLE	SHEET NO.
CONTROL					CDJ-1143-CHIP	2
PART NO	PART NAME	TYPE	DESCRIPTION	CODE		
C43	CAP,FXD C CER	C3216JB1H103K-E-TP	50V 0.01UF	SCAAD00789		
C45	CAP,FXD CER	C3216JB1H102K-E-TP	1000PF 50V	SCAAD01267		
C46	CAP,FXD CER	C3216JB1H102K-E-TP	1000PF 50V	SCAAD01267		
C47	CAP,FXD CER	C3216JB1H102K-E-TP	1000PF 50V	SCAAD01267		
C48	CAP,FXD CER	C3216JB1H102K-E-TP	1000PF 50V	SCAAD01267		
C52	CAP,FXD C CER	C3216JF1H104Z-E-TP	50V 0.1UF	SCAAD01268		
C53	CAP,FXD C CER	C3216JF1H104Z-E-TP	50V 0.1UF	SCAAD01268		
C54	CAP,FXD C CER	C3216JB1H103K-E-TP	50V 0.01UF	SCAAD00789		
C55	CAP,FXD CER	C3216JB1H102K-E-TP	1000PF 50V	SCAAD01267		
C56	CAP,FXD CER	C3216JB1H102K-E-TP	1000PF 50V	SCAAD01267		
C57	CAP,FXD CER	C3216JB1H102K-E-TP	1000PF 50V	SCAAD01267		
C58	CAP,FXD CER	C3216JB1H102K-E-TP	1000PF 50V	SCAAD01267		
C62	CAP,FXD CER	C3216JB1H102K-E-TP	1000PF 50V	SCAAD01267		
C63	CAP,FXD CER	C3216JB1H102K-E-TP	1000PF 50V	SCAAD01267		
C64	CAP,FXD TANTAL	267M1602 105ML	16V 1UF	5CSAC01050		
C65	CAP,FXD C CER	C3216JB1H103K-E-TP	50V 0.01UF	SCAAD00789		
C66	CAP,FXD C CER	C3216JB1H103K-E-TP	50V 0.01UF	SCAAD00789		
C67	CAP,FXD TANTAL	267M1602 105ML	16V 1UF	5CSAC01050		
C68	CAP,FXD C CER	C3216JB1H103K-E-TP	50V 0.01UF	SCAAD00789		
C69	CAP,FXD C CER	C3216JF1H104Z-E-TP	50V 0.1UF	SCAAD01268		
C70	CAP,FXD C CER	C3216JB1H103K-E-TP	50V 0.01UF	SCAAD00789		
C71	CAP,FXD C CER	C3216JB1H103K-E-TP	50V 0.01UF	SCAAD00789		
C72	CAP,FXD C CER	C3216JB1H103K-E-TP	50V 0.01UF	SCAAD00789		
C73	CAP,FXD C CER	C3216JB1H103K-E-TP	50V 0.01UF	SCAAD00789		
C74	CAP,FXD ELCTLT	ECE-V1CA470P	47UF 16V	5CEAA02625		
C75	CAP,FXD ELCTLT	ECE-V1CA470P	47UF 16V	5CEAA02625		
C111	CAP,FXD C CER	C3216JB1H103K-E-TP	50V 0.01UF	SCAAD00789		
C112	CAP,FXD C CER	C3216JB1H103K-E-TP	50V 0.01UF	SCAAD00789		
C113	CAP,FXD C CER	C3216JB1H103K-E-TP	50V 0.01UF	SCAAD00789		
C114	CAP,FXD C CER	C3216JB1H103K-E-TP	50V 0.01UF	SCAAD00789		
C115	CAP,FXD C CER	C3216JB1H103K-E-TP	50V 0.01UF	SCAAD00789		
C116	CAP,FXD C CER	C3216JB1H103K-E-TP	50V 0.01UF	SCAAD00789		
C117	CAP,FXD C CER	C3216JB1H103K-E-TP	50V 0.01UF	SCAAD00789		
C118	CAP,FXD C CER	C3216JB1H103K-E-TP	50V 0.01UF	SCAAD00789		
C119	CAP,FXD C CER	C3216JB1H103K-E-TP	50V 0.01UF	SCAAD00789		

PARTS LIST

CONTROL					TITLE	SHEET NO.
					CDJ-1143-CHIP	5
PART NO	PART NAME	TYPE	DESCRIPTION	CODE		
L31	COIL	LQH3N101K04	100UH	5LCAP00214		
L32	COIL	LQH3N101K04	100UH	5LCAP00214		
L34	COIL	LQH3N101K04	100UH	5LCAP00214		
L35	COIL	LQH3N101K04	100UH	5LCAP00214		
L36	COIL	LQH3N101K04	100UH	5LCAP00214		
L37	COIL	LQH3N101K04	100UH	5LCAP00214		
L38	COIL	LQH3N101K04	100UH	5LCAP00214		
L39	COIL	LQH3N101K04	100UH	5LCAP00214		
L41	COIL	LQH3N101K04	100UH	5LCAP00214		
L42	COIL	LQH3N101K04	100UH	5LCAP00214		
L43	COIL	LQH3N101K04	100UH	5LCAP00214		
L51	COIL	LQH3N101K04	100UH	5LCAP00214		
L55	COIL	LQH3N101K04	100UH	5LCAP00214		
L56	COIL	LQH3N101K04	100UH	5LCAP00214		
L68	COIL	LQH3N101K04	100UH	5LCAP00214		
PC1	PCB	H-6PCED00907E	CDJ-1143	6PCED00907		
R1	RESISTOR	CFXD ERJ-8GEYJ104V	1/8W 100K OHM	5REAG01762		
R2	RESISTOR	FXD ERJ-8GEYJ470V	1/8W 47 OHM	5REAG01722		
R3	RESISTOR	FXD ERJ-8GEYJ103V	1/8W 10K OHM	5REAG01750		
R4	RESISTOR	CFXD ERJ-8GEYJ104V	1/8W 100K OHM	5REAG01762		
R7	RESISTOR	FXD ERJ-8GEYJ152V	1/8W 1.5K OHM	5REAG01740		
R8	RESISTOR	FXD ERJ-8GEYJ152V	1/8W 1.5K OHM	5REAG01740		
R9	RESISTOR	FXD ERJ-8GEYJ103V	1/8W 10K OHM	5REAG01750		
R10	RESISTOR	FXD ERJ-8GEYJ103V	1/8W 10K OHM	5REAG01750		
R11	RESISTOR	FXD ERJ-8GEYJ103V	1/8W 10K OHM	5REAG01750		
R12	RESISTOR	FXD ERJ-8GEYJ222V	1/8W 2.2K OHM	5REAG01742		
R13	RESISTOR	FXD ERJ-8GEYJ222V	1/8W 2.2K OHM	5REAG01742		
R14	RESISTOR	FXD ERJ-8GEYJ103V	1/8W 10K OHM	5REAG01750		
R15	RESISTOR	FXD ERJ-8GEYJ103V	1/8W 10K OHM	5REAG01750		
R16	RESISTOR	CFXD ERJ-8GEYJ101V	1/8W 100 OHM	5REAG01726		
R18	RESISTOR	FXD ERJ-8GEYJ103V	1/8W 10K OHM	5REAG01750		
R19	RESISTOR	FXD ERJ-8GEYJ222V	1/8W 2.2K OHM	5REAG01742		
R20	RESISTOR	FXD ERJ-8GEYJ102V	1/8W 1K OHM	5REAG01738		
R21	RESISTOR	FXD ERJ-8GEYJ102V	1/8W 1K OHM	5REAG01738		
R22	RESISTOR	FXD ERJ-8GEYJ102V	1/8W 1K OHM	5REAG01738		

PARTS LIST

CONTROL					TITLE	SHEET NO.
					CDJ-1143-CHIP	4
PART NO	PART NAME	TYPE	DESCRIPTION	CODE		
CD9	DIODE	1SS187 TE85L		5TXAD00397		
CD10	DIODE	1SS187 TE85L		5TXAD00397		
CD11	DIODE	1SS187 TE85L		5TXAD00397		
CD12	DIODE	1SS187 TE85L		5TXAD00397		
CD13	DIODE	1SS187 TE85L		5TXAD00397		
CD14	DIODE	1SS187 TE85L		5TXAD00397		
CD15	DIODE	1SS187 TE85L		5TXAD00397		
CD16	DIODE	1SS187 TE85L		5TXAD00397		
CD18	DIODE	1SS187 TE85L		5TXAD00397		
CD19	DIODE	1SS187 TE85L		5TXAD00397		
IC2	IC	TC74HC573AF-TP1		5DDAE01302		
IC3	IC	HN58C65FP-25T		5DAAG00494		
IC4	IC	MSM81C55-5GS		5DDAG00358		
IC5	IC	TC74HC573AF-TP1		5DDAE01302		
IC7	IC	TC74HC4538AF-TP1		5DDAE01905		
IC8	IC	TC74HC139AF-TP1		5DDAE01185		
IC10	IC	TC4053BF-TP1		5DDAE01214		
IC11	IC	TC74HC390AF-TP1		5DDAE01906		
IC14	IC	NJM4200M-T1		5DAAN00379		
IC15	IC	NJM3403AM-T1		5DAAN00567		
IC16	IC	NJM3403AM-T1		5DAAN00567		
IC17	IC	NJM3403AM-T1		5DAAN00567		
IC18	IC	T062381F		5DDAE02102		
IC19	IC	T062083F-TP1		5DDAE01907		
IC21	IC	TC74HC04AF-TP1		5DDAE01187		
IC22	IC	TC74HC04AF-TP1		5DDAE01187		
IC23	IC	TC74HCT04AF-TP1		5DDAE01908		
IC24	IC	TC74HC00AF-TP1		5DDAE01298		
IC25	IC	TC74HC02AF-TP1		5DDAE01527		
IC26	IC	TC74HC08AF-TP1		5DDAE01295		
L11	COIL	LQH3N101K04	100UH	5LCAP00214		
L12	COIL	LQH3N101K04	100UH	5LCAP00214		
L26	COIL	LQH3N101K04	100UH	5LCAP00214		
L27	COIL	LQH3N101K04	100UH	5LCAP00214		
L30	COIL	LQH3N101K04	100UH	5LCAP00214		

PARTS LIST

PARTS LIST

CONTROL		TITLE		SHEET NO.	
		CDJ-1143-CHIP		7	
PART NO	PART NAME	TYPE	DESCRIPTION	CODE	
R65	RESISTOR CFXD	ERJ-8GEYJ101V	1/8W 100 OHM	5REAG01726	
R68	RESISTOR FXD	ERJ-8GEYJ102V	1/8W 1K OHM	5REAG01738	
R69	RESISTOR FXD	ERJ-8GEYJ152V	1/8W 1.5K OHM	5REAG01740	
R75	RESISTOR FXD	ERJ-8GEYJ102V	1/8W 1K OHM	5REAG01738	
R76	RESISTOR CFXD	ERJ-8GEYJ681V	1/8W 680 OHM	5REAG01736	
R77	RESISTOR FXD	ERJ-8GEYJ103V	1/8W 10K OHM	5REAG01750	
R78	RESISTOR FXD	ERJ-8GEYJ103V	1/8W 10K OHM	5REAG01750	
R79	RESISTOR CFXD	ERJ-8GEYJ104V	1/8W 100K OHM	5REAG01762	
R81	RESISTOR FXD	ERJ-8GEYJ620V		5REAG02379	
R82	RESISTOR FXD	ERJ-8GEYJ470V	1/8W 47 OHM	5REAG01722	
R83	RESISTOR FXD	ERJ-8GEYJ102V	1/8W 1K OHM	5REAG01738	
R84	RESISTOR FXD	ERJ-8GEYJ331V	1/8W 330 OHM	5REAG01732	
R85	RESISTOR FXD	ERJ-8GEYJ221V	1/8W 220 OHM	5REAG01730	
R86	RESISTOR FXD	ERJ-8GEYJ470V	1/8W 47 OHM	5REAG01722	
R87	RESISTOR FXD	ERJ-8GEYJ223V	1/8W 22K OHM	5REAG01754	
R88	RESISTOR FXD	ERJ-8GEYJ684V		5REAG01772	
R89	RESISTOR FXD	ERJ-8GEYJ332V	1/8W 3.3K OHM	5REAG01744	
R90	RESISTOR FXD	ERJ-8GEYJ222V	1/8W 2.2K OHM	5REAG01742	
R91	RESISTOR FXD	ERJ-8GEYJ331V	1/8W 330 OHM	5REAG01732	
R92	RESISTOR FXD	ERJ-8GEYJ102V	1/8W 1K OHM	5REAG01738	
R96	RESISTOR FXD	ERJ-8GEYJ102V	1/8W 1K OHM	5REAG01738	
R99	RESISTOR FXD	ERJ-8GEYJ103V	1/8W 10K OHM	5REAG01750	
R100	RESISTOR FXD	ERJ-8GEYJ222V	1/8W 2.2K OHM	5REAG01742	
R101	RESISTOR FXD	ERJ-8GEYJ102V	1/8W 1K OHM	5REAG01738	
R102	RESISTOR FXD	ERJ-8GEYJ332V	1/8W 3.3K OHM	5REAG01744	
R103	RESISTOR FXD	ERJ-8GEYJ222V	1/8W 2.2K OHM	5REAG01742	
R104	RESISTOR CFXD	ERJ-8GEYJ104V	1/8W 100K OHM	5REAG01762	
R105	RESISTOR CFXD	ERJ-8GEYJ104V	1/8W 100K OHM	5REAG01762	
R108	RESISTOR CFXD	ERJ-8GEYJ104V	1/8W 100K OHM	5REAG01762	
R120	RESISTOR FXD	ERJ-8GEYJ334V	1/8W 330K OHM	5REAG01768	
RV1	RESISTOR VAR	ST-4TB 5K OHM	5K	5RVAL00043	
RV3	RESISTOR VAR	ST-4TB 2K OHM		5RVAL00050	
RV4	RESISTOR VAR	ST-4TB 2K OHM		5RVAL00050	
RV5	RESISTOR VAR	ST-4TB 5K OHM	5K	5RVAL00043	
TR1	TRANSISTOR	2SA1344-TB		5STAAL00004	

CONTROL		TITLE		SHEET NO.	
		CDJ-1143-CHIP		8	
PART NO	PART NAME	TYPE	DESCRIPTION	CODE	
R23	RESISTOR FXD	ERJ-8GEYJ103V	1/8W 10K OHM	5REAG01750	
R24	RESISTOR FXD	ERJ-8GEYJ102V	1/8W 1K OHM	5REAG01738	
R25	RESISTOR FXD	ERJ-8GEYJ102V	1/8W 1K OHM	5REAG01738	
R26	RESISTOR CFXD	ERJ-8GEYJ101V	1/8W 100 OHM	5REAG01726	
R27	RESISTOR CFXD	ERJ-8GEYJ101V	1/8W 100 OHM	5REAG01726	
R28	RESISTOR CFXD	ERJ-8GEYJ101V	1/8W 100 OHM	5REAG01726	
R29	RESISTOR CFXD	ERJ-8GEYJ101V	1/8W 100 OHM	5REAG01726	
R32	RESISTOR FXD	ERJ-8GEYJ103V	1/8W 10K OHM	5REAG01750	
R33	RESISTOR FXD	ERJ-8GEYJ103V	1/8W 10K OHM	5REAG01750	
R34	RESISTOR FXD	ERJ-8GEYJ471V	1/8W 470 OHM	5REAG01734	
R35	RESISTOR FXD	ERJ-8GEYJ472V	1/8W 4.7K OHM	5REAG01746	
R36	RESISTOR FXD	ERJ-8GEYJ102V	1/8W 1K OHM	5REAG01738	
R37	RESISTOR FXD	ERJ-8GEYJ620V		5REAG02379	
R38	RESISTOR FXD	ERJ-8GEYK2R2V		5REAG02210	
R40	RESISTOR FXD	ERJ-8GEYJ103V	1/8W 10K OHM	5REAG01750	
R41	RESISTOR FXD	ERJ-8GEYJ222V	1/8W 2.2K OHM	5REAG01742	
R42	RESISTOR FXD	ERJ-8GEYJ222V	1/8W 2.2K OHM	5REAG01742	
R43	RESISTOR FXD	ERJ-8GEYJ222V	1/8W 2.2K OHM	5REAG01742	
R44	RESISTOR FXD	ERJ-8GEYJ222V	1/8W 2.2K OHM	5REAG01742	
R46	RESISTOR CFXD	ERJ-8GEYJ104V	1/8W 100K OHM	5REAG01762	
R47	RESISTOR CFXD	ERJ-8GEYJ104V	1/8W 100K OHM	5REAG01762	
R48	RESISTOR FXD	ERJ-8GEYJ102V	1/8W 1K OHM	5REAG01738	
R51	RESISTOR CFXD	ERJ-8GEYJ104V	1/8W 100K OHM	5REAG01762	
R52	RESISTOR FXD	ERJ-8GEYJ332V	1/8W 3.3K OHM	5REAG01744	
R53	RESISTOR FXD	ERJ-8GEYJ222V	1/8W 2.2K OHM	5REAG01742	
R54	RESISTOR FXD	ERJ-8GEYJ105V	1/8W 1M OHM	5REAG01774	
R55	RESISTOR FXD	ERJ-8GEYJ105V	1/8W 1M OHM	5REAG01774	
R56	RESISTOR FXD	ERJ-8GEYJ333V	1/8W 33K OHM	5REAG01756	
R57	RESISTOR FXD	ERJ-8GEYJ333V	1/8W 33K OHM	5REAG01756	
R58	RESISTOR FXD	ERJ-8GEYJ333V	1/8W 33K OHM	5REAG01756	
R59	RESISTOR FXD	ERJ-8GEYJ393V	1/8W 39K OHM	5REAG01757	
R60	RESISTOR FXD	ERJ-8GEYJ105V	1/8W 1M OHM	5REAG01774	
R61	RESISTOR CFXD	ERJ-8GEYJ104V	1/8W 100K OHM	5REAG01762	
R62	RESISTOR CFXD	ERJ-8GEYJ104V	1/8W 100K OHM	5REAG01762	
R64	RESISTOR FXD	ERJ-8GEYJ103V	1/8W 10K OHM	5REAG01750	

97

PARTS LIST

		TITLE		SHEET NO.	
		DISPLAY BOARD		CML-334	
				1	
PART NO	PART NAME	TYPE	DESCRIPTION	CODE	
C1	CAP.FXD PLSTC	ECQ-B1H103KZ	50V 0.01UF	5CRAA00475	
C2	CAP.FXD ELCTLT	ECEA1EU100	25V 10UF	5CEAA01845	
C3	CAP.FXD CER	DD112B103K50	50V 10000PF	5CBAB00403	
C31	CAP.FXD CER	DD104B102K50	50V 1000PF	5CBAB00302	
C32	CAP.FXD CER	DD104B102K50	50V 1000PF	5CBAB00302	
C33	CAP.FXD CER	DD104B102K50	50V 1000PF	5CBAB00302	
C34	CAP.FXD CER	DD104B102K50	50V 1000PF	5CBAB00302	
C35	CAP.FXD CER	DD104B102K50	50V 1000PF	5CBAB00302	
C36	CAP.FXD CER	DD104B102K50	50V 1000PF	5CBAB00302	
CD1	LED	HDSP-5721		5TZAY00109	
CD2	DIODE	IS1U60L		5TXBP00014	
CD3	DIODE	LD-201VR	RED	5TXCW00015	
IC1	IC	TD62380P		5DDAE01818	
J111	CONNECTOR	B9B-PH-K-S		5JWAP00252	
J112	CONNECTOR	B11B-PH-K-S		5JWAP00390	
J113	CONNECTOR	B8B-PH-K-S		5JWAP00389	
J114	CONNECTOR	B13B-PH-K-S	13P	5JWAP00400	
J115	CONNECTOR	B14B-PH-K-S	14P	5JWAP00337	
PC1	PCB	H-6PCED00910C	CML-334	6PCED00910	
R11	RESISTOR	EXB-F8V510J		5RZAS00756	
R12	RESISTOR	EXB-F8V510J		5RZAS00756	
R13	RESISTOR FXD	RKLB8-102J		5REAE00188	
R14	RESISTOR	EXB-F8V-102J	1KX4	5RZAS00456	
R15	RESISTOR FXD	EXB-F5E102J		5RZAS00429	
R19	RESISTOR FXD	ERD-25PJ151	1/4W 150 OHM	5RDAA01145	
R20	RESISTOR FXD	ERD-25PJ151	1/4W 150 OHM	5RDAA01145	
R25	RESISTOR FXD	ERD-25PJ102	1/4W 1K OHM	5RDAA01181	
R26	RESISTOR FXD	ERD-25PJ102	1/4W 1K OHM	5RDAA01181	
R35	RESISTOR FXD	ERD-25PJ222	1/4W 2.2K OHM	5RDAA01172	
R36	RESISTOR FXD	ERD-25PJ222	1/4W 2.2K OHM	5RDAA01172	
TB1	TERMINAL	PB-1-S		5JTCW00028	
TB2	TERMINAL	PB-1-S		5JTCW00028	
TB3	TERMINAL	PB-1-S		5JTCW00028	
TB4	TERMINAL	PB-1-S		5JTCW00028	
TR1	TRANSISTOR	2SA950		5TAAG00124	

9.14 CML-334 Display

PARTS LIST

		TITLE		SHEET NO.	
		CONTROL		CDJ-1143-CHIP	
				8	
PART NO	PART NAME	TYPE	DESCRIPTION	CODE	
TR5	TRANSISTOR	2SA1344-TB		5TAAL00004	
TR7	TRANSISTOR	2SC3398-TB		5TCAZ00011	

PARTS LIST

		TITLE		SHEET NO.
		SWITCH PANEL	CSD-387	1
PART NO	PART NAME	TYPE	DESCRIPTION	CODE
CD1	LED	PG5551KY		5TZAW00055
CD2	LED	AY5551K	YELLOW	5TZAW00132
CD3	LED	AY5551K	YELLOW	5TZAW00132
CD4	LED	AY5551K	YELLOW	5TZAW00132
CD5	LED	AY5551K	YELLOW	5TZAW00132
CD6	LED	AY5551K	YELLOW	5TZAW00132
CD7	LED	AY5551K	YELLOW	5TZAW00132
CD8	LED	AY5551K	YELLOW	5TZAW00132
CD9	LED	AY5551K	YELLOW	5TZAW00132
CD11	LED	TLSG208		5TZAD00370
CD12	LED	TLSG208		5TZAD00370
CD13	LED	AY5551K	YELLOW	5TZAW00132
CD14	LED	AY5551K	YELLOW	5TZAW00132
CD15	LED	AY5551K	YELLOW	5TZAW00132
CD16	LED	AY5551K	YELLOW	5TZAW00132
CD21	DIODE	1S1585		5TXAD00038
CD22	DIODE	1S1585		5TXAD00038
CD23	DIODE	1S1585		5TXAD00038
CD24	DIODE	1S1585		5TXAD00038
CD25	DIODE	1S1585		5TXAD00038
CD26	DIODE	1S1585		5TXAD00038
CD27	DIODE	1S1585		5TXAD00038
CD28	DIODE	1S1585		5TXAD00038
CD29	DIODE	1S1585		5TXAD00038
CD30	DIODE	1S1585		5TXAD00038
CD31	DIODE	1S1585		5TXAD00038
CD32	DIODE	1S1585		5TXAD00038
CD33	DIODE	1S1585		5TXAD00038
PC1	PCB	H-6PCED00914A	CSD-387	6PCED00914
S1	SWITCH	B3F-1022		5SCAP00026
S2	SWITCH	B3F-1022		5SCAP00026
S3	SWITCH	B3F-1022		5SCAP00026
S4	SWITCH	B3F-1022		5SCAP00026
S5	SWITCH	B3F-1022		5SCAP00026
S6	SWITCH	B3F-1022		5SCAP00026

9.15 CSD-387 Switch Panel

PARTS LIST

		TITLE		SHEET NO.
		DISPLAY BOARD	CML-334	2
PART NO	PART NAME	TYPE	DESCRIPTION	CODE
TR2	TRANSISTOR	2SA950		5TAAG00124
TR3	TRANSISTOR	2SA950		5TAAG00124
TR4	TRANSISTOR	2SA950		5TAAG00124
TR5	TRANSISTOR	2SA1015-Y		5TAAG00070
TR6	TRANSISTOR	2SA1015-Y		5TAAG00070

9.16 JRL-2000F-ACC Liner Accessory

PARTS LIST

LINEAR ACCESORY		TITLE		SHEET NO.
		JRL-2000F-ACC		1
PART NO	PART NAME	TYPE	DESCRIPTION	CODE
B1	BATTERY	SUM-3(S)-2P	1 PACK (2PCS)	5ZBAC00019
F1	FUSE	F-7165-15A	15A	5ZFAF00128
F2	FUSE	MF60NR-15A	15A	5ZFAD00173
P2	CONNECTOR	HDAB-15P		5JBAB01480
P2-C	CONNECTOR	HDA-CTF		5JBAB01416

PARTS LIST

SWITCH PANEL		TITLE		SHEET NO.
		CSD-387		2
PART NO	PART NAME	TYPE	DESCRIPTION	CODE
S7	SWITCH	B3F-1022		5SCAP00026
S8	SWITCH	B3F-1022		5SCAP00026
S9	SWITCH	B3F-1022		5SCAP00026
S10	SWITCH	B3F-1022		5SCAP00026
S11	SWITCH	B3F-1022		5SCAP00026
S12	SWITCH	B3F-1022		5SCAP00026
S13	SWITCH	B3F-1022		5SCAP00026
W101	CABLE	H-6ZCED11011	9P,200	6ZCED11011
W102	CABLE	H-6ZCED11012	11P,100	6ZCED11012

99

10

15

20

25

30

35

10

15

20

25

30

35