

CODE ON LABEL: SS 5206

copy protection  
CPU or controller (18 pins)

PIN	SYMBOL	flatcable	PIN	SYMBOL	flatcable
1	A15-Vpp	34	28	Vcc	33+1
2	A12	32	27	A14	31
3	A7	30	26	A13-Vcc	29+3
4	A6	28	25	A8	27
5	A5	26	24	A9	25
6	A4	24	23	A11-Vpp	23
7	A3	22	22	/OE-Vpp	21
8	A2	20	21	A10	19
9	A1	18	20	/CE	17 (ZIF1)
10	A0	16	19	D7	15
11	D0	14	18	D6	13
12	D1	12	17	D5	11
13	D2	10	16	D4	9
14	GND	8+2	15	D3	7
20-ZIF2	/CE	6			
20-ZIF3	/CE	5			
22-ZIF4	/CE	4			

NOTE: The flatcablewire numbering on the PCB is NOT according to the standard normalisation

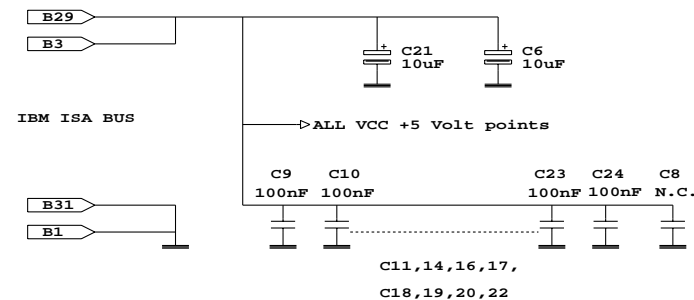

Title		
SUNSHINE EW904B EPROM PROGRAMMER		
Size	Document Number	REV
B	REVERSE ENGINEERED BY W. GEERAERT	
Date:	June 19, 1999	Sheet 1 of 4