

1SV100

Silicon Epitaxial Planar Type

Variable Capacitance Diode

AM RADIO BAND TUNING APPLICATIONS.

FEATURES:

- High Capacitance Ratio : $C_{1V}/C_{9V}=17(\text{Min.})$
- High Q : $Q=450(\text{Typ.})$
- Small Package
- Low Voltage Operation : 1V-9V

MAXIMUM RATINGS ($T_a=25^\circ\text{C}$)

CHARACTERISTIC	SYMBOL	RATING	UNIT
Reverse Voltage	V_R	15	V
Junction Temperature	T_j	125	$^\circ\text{C}$
Storage Temperature Range	T_{stg}	-55 ~ 125	$^\circ\text{C}$

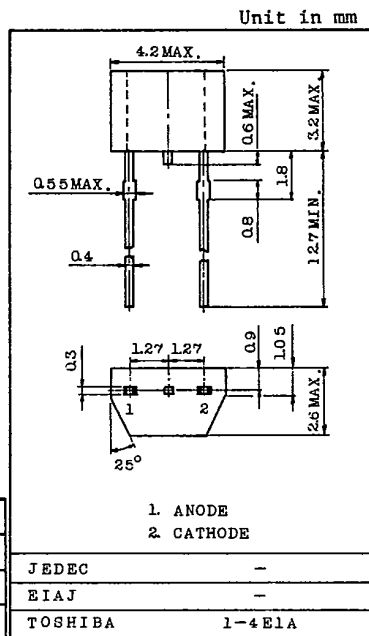

Weight : 0.09g

ELECTRICAL CHARACTERISTICS ($T_a=25^\circ\text{C}$)

CHARACTERISTIC	SYMBOL	TEST CONDITION	MIN.	TYP.	MAX.	UNIT
Reverse Voltage	V_R	$I_R=10\mu\text{A}$	15	-	-	V
Reverse Current	I_R	$V_R=15\text{V}$	-	-	50	nA
Capacitance	C_{1V}	$V_R=1\text{V}, f=1\text{MHz}$	450	-	600	pF
Capacitance	C_{9V}	$V_R=9\text{V}, f=1\text{MHz}$	-	-	35	pF
Capacitance Ratio	C_{1V}/C_{9V}	-	17	-	-	
Figure of Merit	Q	$V_R=1\text{V}, f=1\text{MHz}$	200	450	-	

Note : Available in matched group for capacitance to 3%.

$$\frac{C(\text{Max.}) - C(\text{Min.})}{C(\text{Min.})} \leq 0.03 \quad (V_R=1\text{V}-9\text{V})$$

and capacitance is classified as Table 1.

Table 1 : Capacitance Data

TEST CONDITION : f=1MHz, Ta=25°C

Unit : pF

No.	C1V	C3V	C5V	C9V
1	452.3~465.8	176.1~181.3	68.43~70.48	20.06~20.66
2	463.5~477.4	180.4~185.8	80.14~72.24	20.57~21.18
3	475.2~489.4	184.9~190.4	71.90~74.05	21.08~21.71
4	487.0~501.6	189.6~195.2	73.70~75.91	21.61~22.25
5	499.2~514.1	194.3~200.1	75.55~77.81	22.14~22.80
6	511.6~526.9	199.2~205.1	77.43~79.75	22.69~23.37
7	524.4~540.1	204.2~210.3	79.36~81.74	23.27~23.96
8	537.5~553.6	209.3~215.5	81.35~83.79	23.85~24.55
9	550.9~567.4	214.5~220.9	83.38~85.88	24.44~25.17
10	564.7~581.6	219.9~226.4	85.47~88.03	25.05~25.80
11	578.9~596.2	225.4~232.1	87.60~90.22	25.68~26.45
12		231.0~237.9	89.79~92.48	26.32~27.10
13		236.7~243.8	92.04~94.80	26.98~27.78
14		242.6~249.8	94.34~97.17	27.66~28.48
15		248.7~256.1	96.70~99.60	28.34~29.19
16		254.9~262.5	99.11~102.08	29.05~29.92
17		261.2~269.0	101.59~104.63	29.78~30.67
18		267.7~275.7	104.13~107.25	30.53~31.44
19		274.4~282.6	106.73~109.93	31.29~32.22
20		281.3~289.7	109.40~112.68	
21		288.3~296.9	112.13~115.49	
22		295.5~304.3	114.93~118.37	
23		302.9~311.9	117.80~121.33	
24		310.4~319.7	120.75~124.37	
25		318.2~327.7	123.77~127.48	
26		326.3~336.0	126.86~130.66	
27		334.4~344.4	130.03~133.93	
28		342.8~353.0	133.29~137.28	
29			136.62~140.71	
30			140.04~144.24	
31			143.53~147.83	
32			147.09~151.50	

- (1) This table is not selection guide, which means only to show the data.
- (2) The number on the vinyl package (on the label in the vinyl package) is to show the capacitance data at each voltage in a matched group.

Example 4 - 3 - 2 - 1
 (C1V) (C3V) (C5V) (C9V)

- (3) The absolute capacitance value is in $\pm 0.5\%$.

1SV100

